

# Mag World



Magliner® modifications by Backstage

# 2023

2023 G à edition

## Index

FAQ .....	2-3	Sand/Dune Wheel Kits .....	99-100
Antenna Base and Risers .....	130	Shelves (Nose) .....	13-14
Arms (Swivel and Offset) .....	31-33	Shelf Safety Lock Kit (Top & Middle Shelves) .....	47
Axle Kits (Quad & Twin) .....	111	Shelves (Junior) .....	35-39
Bags .....	90	Shelves (Senior) .....	42-454
C-Stand Holders .....	76-77	Sound Tray (Junior) .....	40-41
Cable Holders .....	88	Sound Tray (Senior) .....	46
Cup Holders .....	93-94	Steady-Cam Riser Unit .....	59
DIT HD Tent .....	74	Steady-Cam Swing Handles .....	61
Dove Tail Mount .....	51	Steady-Cam Vest Holder .....	60
Drawers and accessories .....	95	Steady-Cam Stand 8" and 6" Wheel Kit .....	62-63
Euroball Mounts (150mm, 100mm, 75mm) .....	52-54	Steady-Cam Stand Front Box Holder .....	64
Flat Screen Video Dual Bracket (Adjustable) with 5/8" Baby Pin .....	104	Steady-Cam Steady-Cam Stand Holder .....	65
Fluid Head Nose Mount .....	55	Steady-Cam Stand Utility Trays .....	66-67
Front Box and Front Box Adapter .....	56-57	Tripod Holder with 5/8" Baby Pin .....	49
Grip/Light Caddy .....	68-69	U-Handle Detachable Cross Bar with Lock .....	48
Headphone Holder .....	89	U-Handle Detachable Cross Bar with Lock and Universal Receiver .....	98
Hi/Lo Hat Holder .....	58	U-Handle 5/8" Baby Pin .....	83
Jockey Boxes .....	101	U-Handle Offset 5/8" Baby Pin .....	84
Keyboard Trays .....	91	Umbrella .....	73
Lap Top Tray .....	29-30	Umbrella Holder .....	72
Light Stand Holders .....	70	Utility Boxes .....	71
Loading Handles .....	34	Vertical 5/8" Baby Pins .....	126-128
Lunch Tray .....	92	Vertical Flat Screen Video Dual Riser (Adj.) with 5/8" Baby Pin .....	129
Magliner Mini .....	4-11	Vertical Drawer Shelf .....	121
Magliner Junior (Stock) .....	15	Vertical Handle .....	119
Magliner Senior (Stock) .....	16	Vertical Keyboard Shelf .....	124
Magliner Junior (Modified) .....	19-20	Vertical Loading Wheel Set .....	118
Magliner Senior (Modified) .....	21	Vertical Nagra Shelf .....	122
Magliner Junior (Vertical) .....	112-118	Vertical Shelf .....	120
Magliner Self Stabilizing C-Stand Carts .....	17-18	Vertical Sliding Shelf .....	123
Mic Boom Grip & Base .....	96-97	Vertical Utility Tray .....	125
Mitchell Mount .....	50	Wheel Conversion Kits .....	22-24
Monitor Arms (Light Duty, Medium Duty, Heavy Duty) .....	107		
Monitor Arm Heavy Duty Nose Adapter .....	110		
Monitor Arm Heavy Duty U-Handle Adapter .....	109		
Monitor Horizontal Cross Bars .....	105-106		
Monitor Tilt Head and Tilt Head Pin Adapter to 5/8" Baby Pin .....	108		
Monitor Video Dual Brackets .....	102-103		
Noses .....	25-28		
Nose Baby Pins .....	78-82		
Photo Caddy .....	12		
Pin Adapters 5/8" .....	85-87		
Rain Tent .....	75		

## Magliner FAQ

### 1. What is the difference between a Magliner Mini, Magliner Junior and a Magliner Senior?

a. The Magliner Senior's frame is 55 1/2" long versus the Magliner Junior's frame at 42 3/4" and the Magliner's Mini frame at 32 1/4". The longer the frame, the bigger the shelf you can use. You may use 24 or 18 inch wide shelves on the Magliner Junior and Senior. The Magliner Mini is only available with 18 inch wide shelves and a special 19 inch wide bottom shelf to be used with a Mac Pro/G5 computer tower.

b. The Magliner Senior (Stock) uses a loading handle located beneath the frame, instead of the Magliner Junior's two push handles.

**Note:** The loading handle on the Magliner Senior (Stock) can only be used in the upright position, since it is located underneath the frame. There are no handles to push from when cart is in the 4-wheel mode.

The Magliner Senior (Stock) and Magliner Junior (Stock) carts use the same locking latch system to change the cart from upright mode to 4-wheels. They also have the same weight capacity and share all other parts such as axles, wheels, nose, and toe plate. Magliner Mini is not available in the stock version.

### 2. What is the difference between a Stock Magliner and a Modified Magliner?

The Magliner Stock models are not altered by Backstage in any way. These models come equipped with 5" stock wheels. (Brakes are optional), a Stock 30" Nose and their own locking latch folding system.

These carts are great if you work for FedEx or UPS and use them to carry boxes from point A to point B. But if you are going to start using your cart as a work station and to transport expensive equipment such as cameras, video or sound gear over rough terrain, grass or cables, then the cart needs to be reinforced and adapted to these needs.

The Magliner Modified version contains the following modifications/alterations.

- a. Nose is reinforced with additional rivets to allow the use of multiple shelves and accessories.
- b. Standard 5" wheels are replaced with our own 8" Wheel Conversion Kit. (pneumatics with brakes)
- c. Magliner's original folding system is replaced with our own.
- d. Axle is bored from 1/8" to 3/16" diameter and wheel cotter pins are replaced with safety quick release pins.
- e. Frame, Nose and U-Handle Bar are pre-drilled to allow user to adapt any of our accessories at a later time.
- f. Magliner Senior's U-Handle Bar is outfitted with push handles and the U-Handle Bar is shortened.

### 3. Are all accessories compatible between the Stock and Modified versions?

No, most accessories will work only with the modified versions. See product requirements.

**4. Can the Magliner still be folded after it has been modified?**

Yes, we have built a system so you can still fold your cart in the upright position.

**5. How do you fold the modified Magliner**

You must first loosen up the prongs that connect the U-Handle to the 8" Wheel Conversion Kit, put your cart in the upright position, insert and slide the U-Handle underneath the cart where it connects to a receiver attached to the bottom of the 8" Wheel Conversion Kit, lock in place with prongs.

**Note: Narrow and Mini Wheel Conversion Kits do not have receivers underneath the cart due to their narrow size.**

**6. I already own a Stock Magliner, can it be modified or do I have to buy a whole new cart?**

No, you can modify your existing cart or we can do it for you. We also repair and service Magliners.

**7. Can I buy replacement parts for my Magliner such as tires, tubes, bearings, etc?**

Yes, we are about the only retail store that keeps Magliner parts in inventory at all times.

**8. I live outside of the United States, can you ship a Magliner to an international destination?**

Yes, we sell a large number of Magliners and accessories outside the U.S., mostly to Europe, Asia and Canada.

**9. How can I pay for a Magliner from abroad?**

You may use a wire transfer service from your bank to ours (a fee of \$ 25.00 USD will be added to your order to cover bank fees at our end) or you may use a credit card such as VISA, Mastercard, Discover or American Express.

**10. Can you take care of the shipping or do I have to arrange it?**

We can take care of it. As soon as you give us the list of items you need, we will get a quote from a shipping agent the same day. We can ship to your location (door-to-door) or you can save some money if we ship it to your local international airport and you pick it up (door-to-airport).

**Note: You will be responsible for all local custom fees, import fees and local taxes. Contact your customs office or customs broker in your particular country to know the fees that need to be paid. We don't have this information.**

**11. Is there any other costs on shipping I should be aware of?**

Yes, the only other charge involved is a packing fee of 5% on all shipments where items need to be packed, labeled and documents prepared.

# Magliner Mini



Magliner Mini shown with 8" Wheel Conversion Kit, Mag 30" HD Nose, Mag Mini 18" Top Shelf and Mag Mini 19" Bottom Shelf

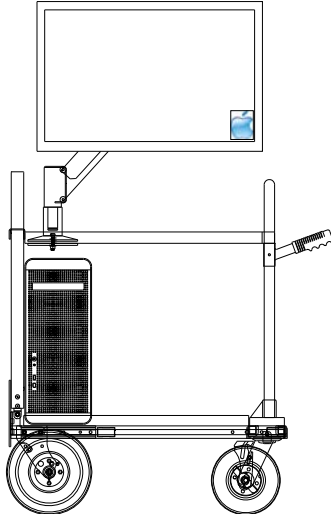

Magliner Mini with Mag LCD Monitor Arm, Mac Pro and 30" Apple Cinema Display (Page 108)

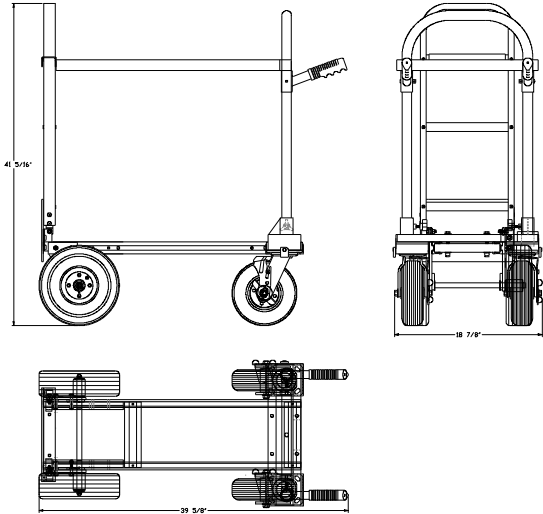

**Part No:** MAG-01 MINI-8X G5  
**Sale price:** \$ 1,525.00  
**Material:** Aluminum/Steel  
**Color:** Natural Aluminum/Steel Zinc Plate  
**Max. Capacity:** 1,000 lbs.  
**Weight:** 69 lbs.  
**Dimensions:** Upright L14 3/4" x W19 1/4" x H34 1/2"  
 On 4-Wheels L39 1/4" x W19 1/4" x H41 1/4"

**Shipping Weight/Dims:** 75 lbs. (L18" x W20" x H36")



Available with all 10" Wheels (4)

**Requirements:** None  
**Conflicts:** Mag Battery Holder  
**Suggestions:** Mag Mini 19" Bottom Aluminum Plate, Mag HD Tent, Mag LCD HD Monitor Arm

The Magliner Mini Cart has been around now for over twenty years. It has been a favorite with still photographers, DIT's and camera/video operators using the latest digital film gear. Cart comes pre-drilled to accept all accessories available.

Available with all around 10" Wheels (4)

**Part No:** MAG-01 MINI-10X G5  
**Sale price:** \$ 1,700.00  
**Material:** Aluminum/Steel  
**Color:** Natural Aluminum/Steel Zinc Plate  
**Max. Capacity:** 1,000 lbs.  
**Weight:** 69 lbs.  
**Dimensions:** Upright L17 7/8" x W19 1/4" x H34 1/2"  
 On 4-Wheels L39 1/4" x W19 1/4" x H44 1/4"

## Mag 8" Wheel Conversion Kit (Mini)



The Magliner 8" Wheel Conversion Kit (Mini) allows you to switch between Pneumatic Wheels and Sand/Dune Wheels. Wheels are removed by using a standard 5/32 hex wrench.

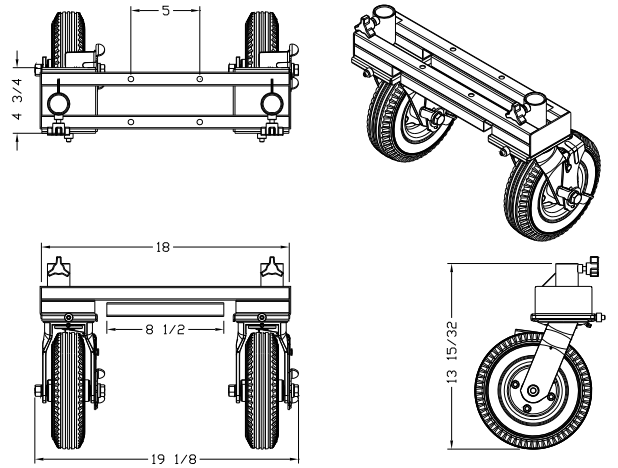

**Part No:** MAG-E MINI  
**Sale price:** \$ 418.00  
**Material:** Steel  
**Color:** Black  
**Max. Capacity:** 500 lbs.  
**Weight:** 24 lbs.  
**Dimensions:** D4 3/4" x W19 1/8" x H13 1/2"

**Shipping Weight/Dims:** 26 lbs. (L21" x W17" x H7")



**Mag Sand/Dune Wheel Kit (MAG-W 18) \$ 910.00**  
**(Page 101)**

**Requirements:** Magliner Mini  
**Conflicts:**  
**Suggestions:** Mag Sand/Dune Wheel



Mag Mini outfitted with Mag Sand/Dune Wheel Kit (MAG-W 18)

## Mag Mini 18" Top Shelf

Top Shelf is pre-drilled to accept Mag Top Shelf Safety Lock system, Mag Sound Tray (Left or Right side), Mag Sliding Drawer with Lock (2-Space, 3-Space, 4-Space), Mag LCD Monitor Arm (Light Duty, Medium Duty, Heavy Duty).

**Part No:** MAG-C MINI

**Sale price:** \$225.00

**Material:** Aluminum

**Color:** Black

**Max. Capacity:** 200 lbs.

**Weight:** 10 lbs.

**Dimensions:** L32 1/8" x W18 1/4" x H2 1/8"  
(ID L28 3/4" x W18" x H1")

**Requirements:** Magliner Mini, Mag 30" HD Nose

**Conflicts:** None

**Suggestions:** Mag Top Shelf Safety Pin and Prong, Mag Mini Sound Tray (Collapsible), Mag Mini 19" Bottom Shelf

**Shipping Weight/Dims:** 11 lbs. (L33" x W19" x H3")

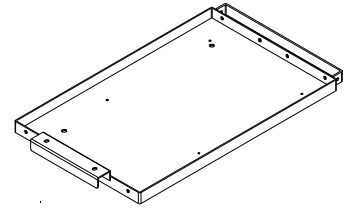
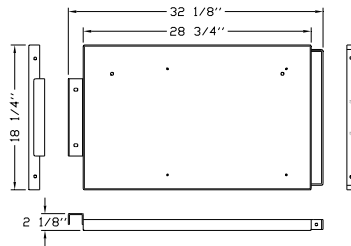

Optional Mag Top Shelf Safety Pin & Prongs (See page 47)

## Mag Mini 18" Top Shelf Keyboard Friendly

Same as the standard Mag Mini 18" Top Shelf, but no lip on left side to allow you to use a keyboard or tablet without interfering with your arm. Pre-drilled to hold Monitor Arm at either end.

**Note:** Sound Tray may only be installed on right side of Top Shelf.

**Part No:** MAG-C MINI KB

**Sale price:** \$235.00

**Material:** Aluminum

**Color:** Black

**Max. Capacity:** 200 lbs.

**Weight:** 10 lbs.

**Dimensions:** L32 1/8" x W18 1/4" x H2 1/2"  
(ID L36 1/4" x W18" x H1")

**Requirements:** Magliner Mini, Mag 30" HD Nose

**Conflicts:** Mag Rolling Sliding Drawer with Lock, Mag Computer Keyboard Tray, Mag Computer Keyboard and Mouse Tray, Mag Mitchell Mount, Mag Dove Tail Mount

**Suggestions:** Mag Top Shelf Safety Pin and Prong, Mag Mini Sound Tray (Collapsible), Mag Mini 19" Bottom Shelf, Mag Mini 18" Middle Shelf

**Shipping Weight/Dims:** 11 lbs. (L33" x W19" x H3")

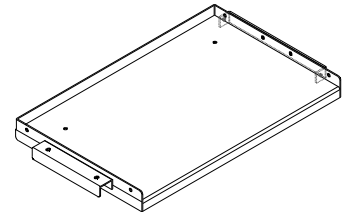
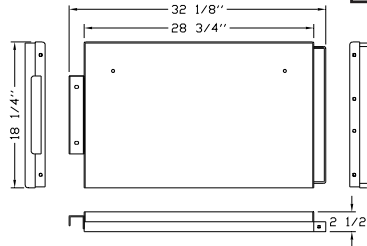

## Mag Mini 18" Middle Shelf

Middle Shelf includes pre-drilled holes on both end brackets, allows Shelf to be locked in place with use of hand prongs.

**Part No:** MAG-C MINI-M

**Sale price:** \$245.00

**Material:** Aluminum

**Color:** Black

**Max. Capacity:** 200 lbs.

**Weight:** 10 lbs.

**Dimensions:** L32 1/4" x W18 1/4" x H 2 1/8"  
(ID L28 3/8" x W18" x H1 1/8")

**Requirements:** Magliner Mini, Mag 30" Adjustable Nose (Heavy Duty), Mag U-Handle Locking Cross Bar

**Conflicts:** Mag Grip/Light Caddy

**Suggestions:**

**Shipping Weight/Dims:** 11 lbs. (L33" x W19" x H3")

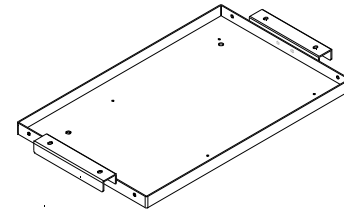
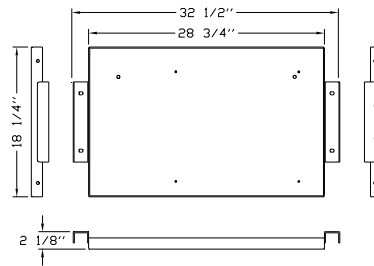

Mag Middle Shelf & Locking Cross Bar

## Mag Mini 19" G5 Bottom Shelf

The G5 Bottom Shelf allows you to place the Mac Pro Tower sideways.

**Part No:** MAG-D MINI G5

**Sale price:** \$210.00

**Material:** Aluminum

**Color:** Black

**Max. Capacity:** 600 lbs.

**Weight:** 10 lbs.

**Dimensions:** L28 3/8" x W19 1/4" x H1 3/8"  
(ID L28 1/8" x W19" x H1 1/8")

**Requirements:** Magliner Mini

**Conflicts:** None

**Suggestions:** Mag Mini Top Sound Tray, Mag Rolling Sliding Drawer with Lock, Mag Lap Top Tray, Mag Mini Rear Loading Handle

**Shipping Weight/Dims:** 10 lbs. (L33" x W20" x H3")

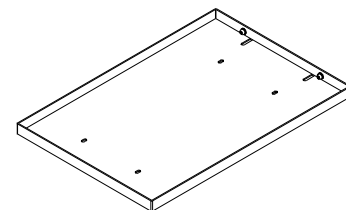
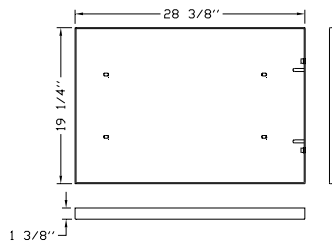



## Mag Mini 19" Bottom Alum. Plate

A good option when a lip is not needed, excellent choice for accommodating flight cases.

**Part No:** MAG-D MINI AP G5  
**Sale price:** \$251.00  
**Material:** Aluminum  
**Color:** Black  
**Max. Capacity:** 600 lbs.  
**Weight:** 13 lbs.  
**Dimensions:** L27 3/4" x W19" x 1/4"

**Shipping Weight/Dims:** 14 lbs. (L28" x W20" x H3")

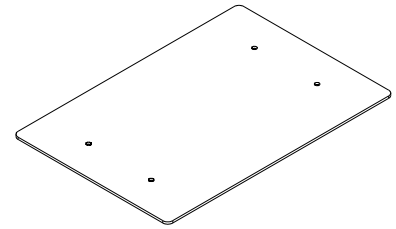
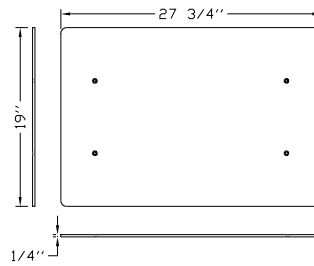

**Requirements:** Magliner Mini  
**Conflicts:**  
**Suggestions:**

## Mag Mini Top Sound Tray (Collapsible)

Sound Tray secures itself to the Mag Mini Top Shelf with hand prongs. Sound Tray is fully collapsible.

**Part No:** MAG-F MINI  
**Sale price:** \$275.00  
**Material:** Aluminum  
**Color:** Black  
**Max. Capacity:** 100 lbs.  
**Weight:** 9 lbs.  
**Dimensions:** L28 1/2" x W9" x H12 5/8"



**Shipping Weight/Dims:** 10 lbs. (L30" x W11" x H4")

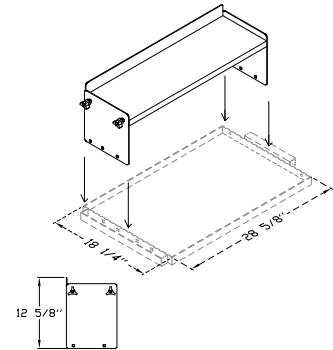
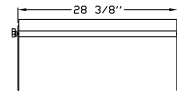

**Requirements:** None  
**Conflicts:** None  
**Suggestions:** Mag Mini 19" G5 Bottom Shelf, Mag Rolling Sliding Drawer with Lock, Mag Lap Top Tray, Mag Mini Rear Loading Handle

## Mag Mini Jockey Box

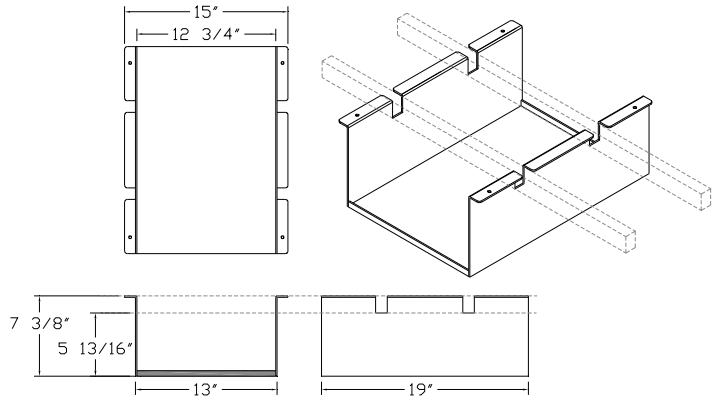
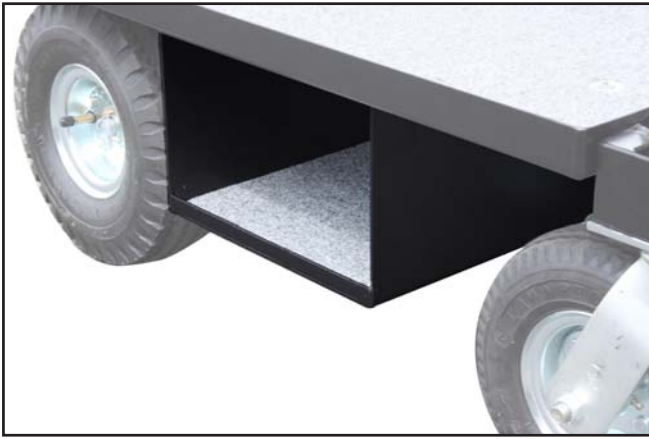

If you need extra storage on your cart, the Mag Mini Jockey Box will do the job. It has openings on both sides, covering 19 inches across. Has a 1/2" lip in front and rear to keep things in place. Outfitted with carpeted floor.

**Part No:** MAG-J MINI  
**Sale price:** \$ 275.00  
**Material:** Aluminum  
**Color:** Black  
**Max. Capacity:** 150 lbs.  
**Weight:** 7 lbs.  
**Dimensions:** D19" x W15" x H7 3/8"

**Shipping Weight/Dims:** 8 lbs. (L19" x W17" x H9")



**Requirements:** Magliner Mini and Mag Mini 19" Bottom Shelf  
**Conflicts:** None  
**Suggestions:** Mag Lap Top Tray, Mag Lap Swing Arm, Mag Mini Utility Box, Mag HD Tent

## Mag Mini Rear Loading Handle



**Part No:** MAG-H MINI  
**Sale price:** \$ 146.00  
**Material:** Aluminum  
**Color:** Black  
**Max. Capacity:** 500 lbs.  
**Weight:** 2 lbs.  
**Dimensions:** D4 3/4" x W6 1/4" x 2 1/2"



**Shipping Weight/Dims:** 2 lbs. (L8" x W5" x H5")

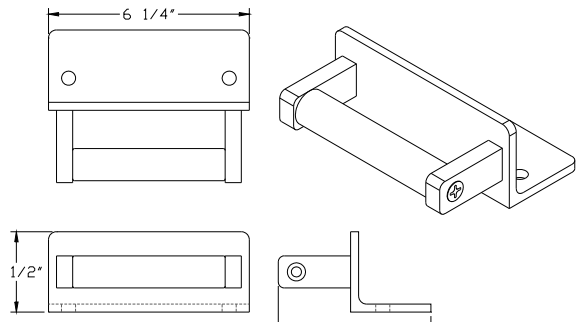

**Requirements:** Magliner Mini

**Conflicts:** None

**Suggestions:** Mag Nose Loading Handles, Mag Lap Top Tray, Mag Lap Top Tray Swing Arm, Mag Flat Screen Video Dual Baby Riser, Mag Flat Screen VESA Plate Adapter

## Mag Mini 27" Utility Box

Mounts and locks on outside lip of any Magliner Shelf. This is a great accessory to put your Sharpie pens, tools, gaffer and photo tapes.

**Part No:** MAG-UB27  
**Sale price:** \$ 145.00  
**Material:** Aluminum  
**Color:** Black  
**Max. Capacity:** 25 lbs.  
**Weight:** 5 lbs.  
**Dimensions:** L28 1/2" x W4 1/4" x H4 1/4"  
 (ID L27" x W4" x H4")

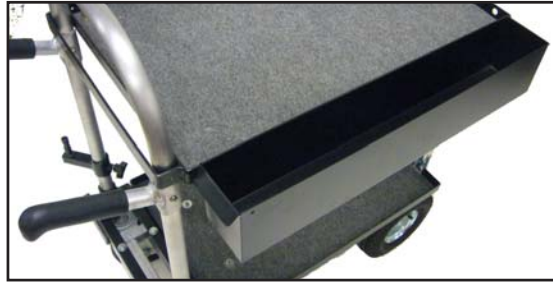

**Shipping Weight/Dims:** 6 lbs. (L6" x W6" x H31")

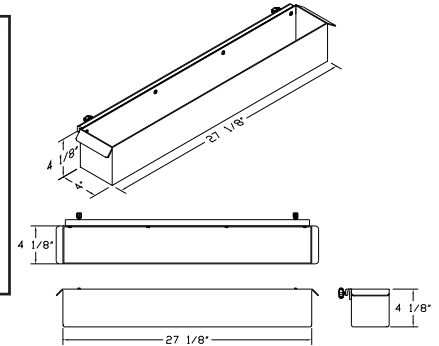

**Requirements:** Magliner Top Shelf

**Conflicts:** None

**Suggestions:** Mag Grip/Light Caddy, Mag C-Stand Holder (4), Mag 3" Cable Holder, Mag 6" Cable Holder, Mag Lunch Tray with retractable Cup Holder, Mag Cup Holder with Bracket

## Mag Mini Monitor Horizontal Cross Bar

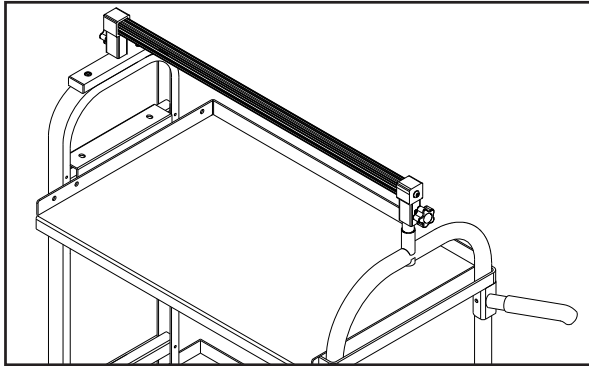

Unit anchors to two 5/8" Baby Pins at each end of the cart (MAG-NP CTR and MAG-S). You can use as many "Slide-On" 5/8" Baby Pins (MAG SHP) to run along the length of the bar allowing you to install up to three (3) 17" Monitors side by side. (MAG-SHP not included)

**Note: You may offset the Monitor Horizontal Cross Bar 9 3/4 inches towards the back or front of the cart by using two Offset Arms (MAG-V OS)**

**Part No:** MAG-SH MINI

**Sale price:** \$ 135.00

**Material:** Steel

**Color:** Black

**Max. Capacity:** 50 lbs.

**Weight:** 4 lbs.

**Dimensions:** L42 1/2" x W1 1/2" x H2 5/8"

**Shipping Weight/Dims:** 4 lbs. (L5" x W5" x H45")



**Part No:** MAG-NP CTR \$ 81.00 (Page 79)

**Part No:** MAG-S \$ 89.00 (Page 84)

**Part No:** MAG-V OS \$ 225.00 (page 33)

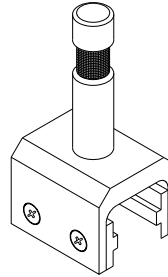

**Slide-On 5/8" Baby Pin**

**Part No:** MAG-SHP

**Sale price:** \$ 75.00

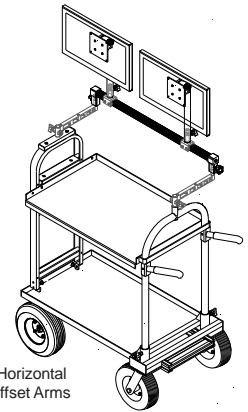

Mag Mini shown with Horizontal Cross Bar using (2) Offset Arms to offset monitors.

**Requirements:** Mag U-Handle 5/8" Baby Pin and Mag 5/8" Nose Pin (Center) or Mag Tripod Holder with 5/8" Baby Pin

**Conflicts:** Mag Sound Tray

**Suggestions:** Mag Offset Arm (MAG-V OS), Mag VESA Tilt Head (LD, MD, HD), Mag LCD 4", 8" or 12" Tilt Head Pin Adapter, Mag Baby Spud 4", 6" or 8" Extension

# Mag Photo Caddy

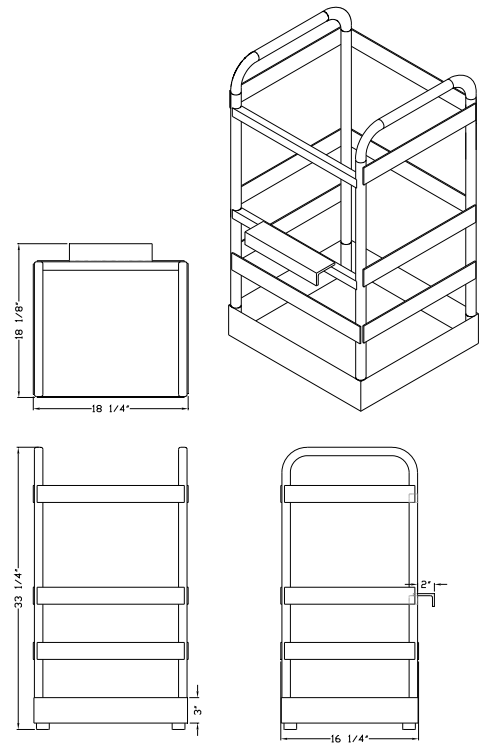

Mag Photo Caddy mounted on Mag Mini

**Part No:** MAG-I PH  
**Sale price:** \$560.00  
**Material:** Aluminum  
**Color:** Black  
**Max. Capacity:** 100 lbs.  
**Weight:** 19 lbs.  
**Dimensions:** D18 1/8" x W16 1/4" x H33 1/4"

**Shipping Weight/Dims:** 20 lbs. (L21" x W21" x H37")



**Requirements:** Mag 30" Nose (Heavy Duty) and Mag Top Shelf (Magliner Mini, Junior or Senior, 18" or 24")  
**Conflicts:** Mag 18" or 24" Middle Shelf, Mag Tripod Holder with 5/8" Baby Pin, Mag Steadi-Cam Vest Holder  
**Suggestions:** Mag Light Stand Holder (Single, Double, Quad), Mag C-Stand Holder (4), Mag LCD Monitor Arm, Mag HD Tent

# Mag Nose Shelf



The Mag Nose Shelf fits into the inner frame of the Mag 30" Nose. It's easily adjustable for height or removal by use of two hand prongs. This accessory was originally made as a custom item for photographers seeking extra space for an already congested cart.

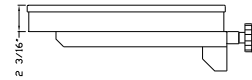
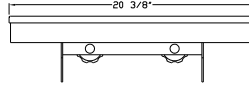
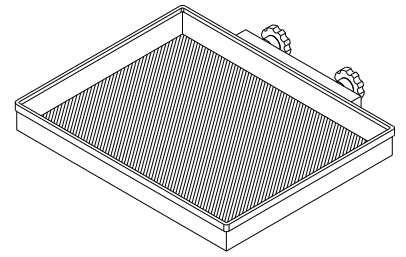
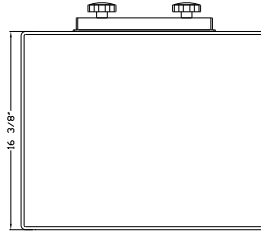

Mag Nose Shelf and Mag Nose  
Nagra Shelf mounted on Mag Mini

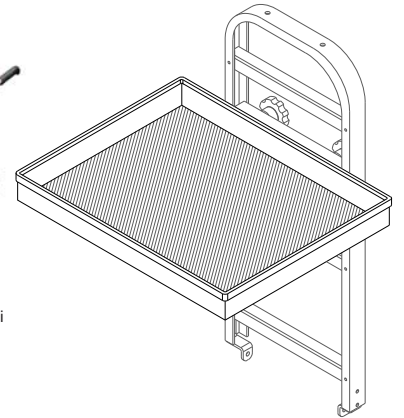

Mag Nose Shelf (Large) Mounted on Mag 30" HD Nose

**Part No:** MAG-N VS  
**Sale price:** \$ 230.00  
**Material:** Steel  
**Color:** Black  
**Max. Capacity:** 50 lbs.  
**Weight:** 11 lbs.  
**Dimensions:** D18 3/4" x W20 3/8" x H5 7/16"  
 ID D15 1/2" x W19 1/2" x H2"

Shipping Weight/Dims: 12 lbs. (L21" x W21" x H7")



**Requirements:** Mag 30" HD Nose, Mag 40" HD Nose  
**Conflicts:** Mag Grip/Light Caddy, Mag Nose Loading Handles, Mag Antenna Base, Mag Photo Caddy  
**Suggestions:** Mag Lap Top Tray, Mag Lap Top Tray Swing Arm, Mag Mini Utility Box, Mag HD Tent

## Mag Nose Nagra Shelf

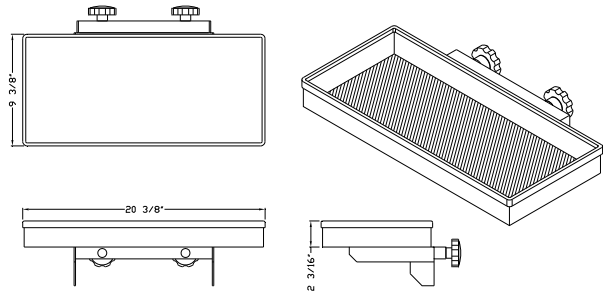

The Mag Nose Nagra Shelf fits into the inner frame of the Mag 30" Nose. It's easily adjustable for height or removal by use of two hand prongs. This accessory was originally made as a custom item for photographers seeking extra space for an already congested cart.

**Part No:** MAG-N VSN  
**Sale price:** \$ 220.00  
**Material:** Steel  
**Color:** Black  
**Max. Capacity:** 50 lbs.  
**Weight:** 8 lbs.  
**Dimensions:** D11 3/4" x W20 3/8" x H5 7/16"  
 ID D8 1/2" x W19 1/2" x H2"

**Shipping Weight/Dims:** 9 lbs. (L21" x W13" x H7")



Mag Nose Shelf and Mag Nose Nagra Shelf mounted on Mag Mini

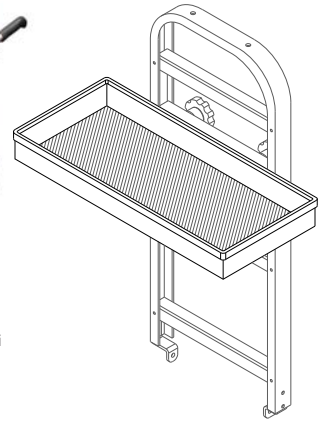

Mag Nose Nagra Shelf Mounted on Mag 30" HD Nose

**Requirements:** Mag 30" HD Nose, Mag 40" HD Nose  
**Conflicts:** Mag Grip/Light Caddy, Mag Nose Loading Handles, Mag Antenna Base, Mag Photo Caddy  
**Suggestions:** Mag Lap Top Tray, Mag Lap Top Tray Swing Arm, Mag Mini Utility Box, Mag HD Tent

# Magliner Junior (Stock) with 30" Nose



Magliner Junior (Stock) in 4-Wheel position with optional 5" Caster Brakes

**Part No:** MAG-01JR-X  
**Sale price:** \$ 629.00  
**Material:** Aluminum/Steel  
**Color:** Natural Aluminum/Steel Zinc Plate  
**Max. Capacity:** 1,000 lbs.  
**Weight:** 43 lbs.  
**Dimensions:** Upright L18 1/2" x W20 3/4" x H51 5/8"  
 On 4-Wheels L47" x W20 3/4" x H41 3/8"

**Requirements:** None  
**Conflicts:** None  
**Suggestions:** Mag Junior 18" or 24" Top Shelf, Mag Junior 18" or 24" Bottom Shelf

**Shipping Weight/Dims:** 48 lbs. (L19" x W15" x H53")



Mag Junior (Stock) With Top & Bottom 18" Shelves



Mag Junior (Stock) with Top, Middle & Bottom 18" Shelves

The Magliner Junior Cart is the most widely used handtruck in the equipment handling industry today. Converts easily from 2-4 wheels by use of a latch release mechanism. We at Backstage have created a number of accessories for this cart to be used in Film & Video production. All Backstage Stock Magliners are outfitted with frame safety locking pin to prevent frame from lifting on its own when used in the 4-wheel position.

**Note:** All Magliners sold by Backstage use split-rim design wheels with tubes. Wheels can be repaired if flat occurs. Beware of tubeless one-piece rims.

## Mag 5" Caster Brake Kit

**Part No:** MAG-W 05-BR  
**Sale price:** \$ 13.00  
**Material:** Steel/Plastic  
**Color:** Steel Zinc Plate/ Black  
**Max. Capacity:** N/A  
**Weight:** 1 lb.



Mag 5" Caster Brake Kit



Upright 2-Wheel position



## Magliner Senior (Stock) w/ 30" Nose



Magliner Senior (Stock) shown in 4-Wheel position  
All Backstage Stock Magliners are outfitted with frame safety locking pin to prevent frame from lifting on its own when used in the 4-wheel position.

**Part No:** MAG-01 SR-X  
**Sale price:** \$ 639.00  
**Material:** Aluminum/Steel  
**Color:** Natural Aluminum/Steel Zinc Plate  
**Max. Capacity:** 1,000 lbs.  
**Weight:** 46 lbs.  
**Dimensions:** Upright L18 1/2" x W20 3/4" x H61 5/8"  
On 4-Wheels L56 1/2" x W20 3/4" x H41 3/8"

**Requirements:** None  
**Conflicts:** None  
**Suggestions:** Mag Senior with Grip Handles, Mag 5" Caster Brake Kit



Magliner Senior (Stock) with optional Grip Handles



Mag Senior (Stock) with Top, Middle and Bottom 18" Shelves

The Magliner Senior Stock Cart has the same features as the Magliner Junior model. The two basic differences are the Senior's length (12 3/4" longer) and the Senior's use of a loading handle instead of two Grip Handles. Converts easily from 2-4 wheels by use of a latch release mechanism. We at Backstage have created a number of accessories for this cart to be used in Film & Video production.

**Note: You may order this cart with optional Grip Handles**

**Part No:** MAG-01 SR-XH  
**Sale price:** \$699.00

**Shipping Weight/Dims:** 52 lbs. (L15" x W19" x H62")



### Mag 5" Caster Brake Kit

**Part No:** MAG-W 05-BR  
**Sale price:** \$ 13.00  
**Material:** Steel/Plastic  
**Color:** Steel Zinc Plate/ Black  
**Max. Capacity:** N/A  
**Weight:** 1 lb.



Mag 5" Caster Brake Kit

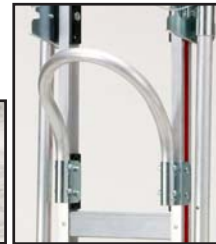

Mag Senior Loading Handle

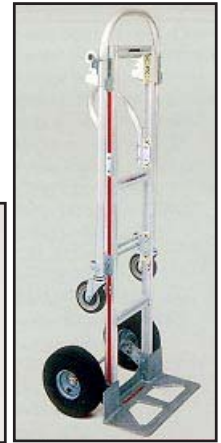

Upright 2-Wheel position

# Magliner Self Stabilizing C-Stand Cart



The Magliner Self Stabilizing C-Stand Cart accomodates (10) C-Stands with Arms and Knuckles (20" & 40"). Cart is equipped with (2) 5" Rotacaster Double Row Multi-Directional Wheels in front and (2) 10" Pneumatic Wheels in the rear, you can turn this cart on a dime with minimal effort. Large 20" x 12 3/4" Base Plate secures C-Stands in place. Cart may be pushed using four wheels or leaned back on two wheels depending on your needs. Cart can also be leaned forward on it's Base Plate to save space when not in use.

**Part No:** MAG-01 SS CS-10X  
**Sale price:** \$ 995.00  
**Material:** Aluminum/Steel  
**Color:** Natural Aluminum / Black Accessories  
**Max. Capacity:** 500 lbs.  
**Weight:** 42 lbs. / 19 kgs.  
**Dimensions:** D39" x W20 1/2" x H44"  
 (D99cm x W52cm x H111.7cm)

**Shipping Weight/Dims:** 50 lbs. (L13" x W22" x H51")



Optional Foam Filled Tires (**WA-10 FOAM OS**) \$ 120.00

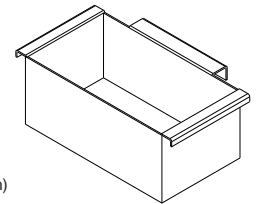
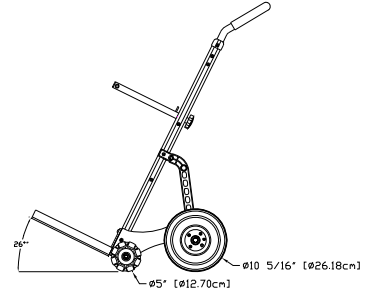
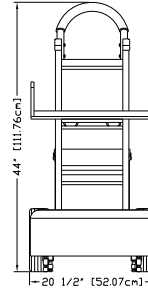
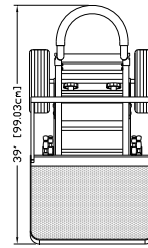

**Part No:** MAG-01 SS UB  
**Sale price:** \$ 195.00  
**Material:** Aluminum  
**Color:** Black  
**Max. Capacity:** 75 lbs.  
**Weight:** 5 lbs. / 2.3 kgs.  
**Dimensions:** D8" x W14" x H6"  
 (D20.3cm x W35.6cm x H15.2cm)

**Requirements:** None  
**Conflicts:** None  
**Suggestions:** Mag Self Stabilizing Cart Utility Box, Foam Filled Tires

# Magliner Self Stabilizing C-Stand Cart (UK)



The Magliner Self Stabilizing C-Stand Cart (UK) accommodates (10) C-Stands with individual storage for C-Stand Arms (20" & 40"). Knuckles can be stored in optional Utility Box. Cart is equipped with (2) 5" Rotacaster Double Row Multi-Directional Wheels in front and (2) 10" Pneumatic Wheels in the rear, you can turn this cart on a dime with minimal effort. Large 20" x 12 3/4" Base Plate secures C-Stands in place. Cart may be pushed using four wheels or leaned back on two wheels depending on your needs. Cart can also be leaned forward on its Base Plate to save space when not in use.

**Part No:** MAG-01 SS CS-10X UK  
**Sale price:** \$ 1,155.00  
**Material:** Aluminum/Steel  
**Color:** Natural Aluminum / Black Accessories  
**Max. Capacity:** 500 lbs.  
**Weight:** 49 lbs. / 22.3 kgs.  
**Dimensions:** D39" x W20 1/2" x H44"  
 (D99cm x W52cm x H111.7cm)

**Shipping Weight/Dims:** 58 lbs. (L16" x W22" x H51")



Optional Foam Filled Tires (**WA-10 FOAM OS**) \$ 120.00

**Requirements:** None  
**Conflicts:** None  
**Suggestions:** Mag Self Stabilizing Cart Utility Box, Foam Filled Tires

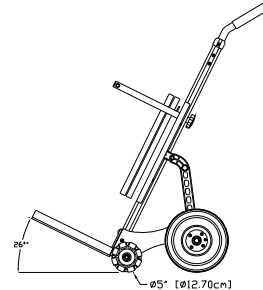
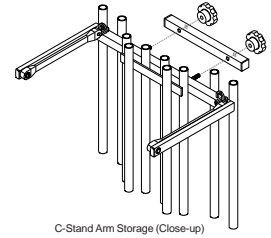
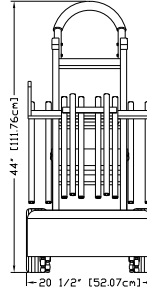
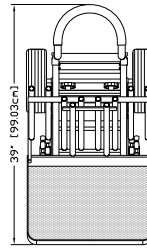

**Part No:** MAG-01 SS UB  
**Sale price:** \$ 195.00  
**Material:** Aluminum  
**Color:** Black  
**Max. Capacity:** 75 lbs.  
**Weight:** 5 lbs. / 2.3 kgs.  
**Dimensions:** D8" x W14" x H6"  
 (D20.3cm x W35.6cm x H15.2cm)



## Magliner Junior (Modified)



Magliner Junior (Modified) outfitted with 8" Wheel Conv. Kit (Standard) Mag Junior 24" Top Shelf, Mag Junior 24" Bottom Shelf and 30" HD Nose. Cart comes pre-drilled to accept all accessories available.

**Part No:** MAG-01 JR-8X 24  
**Sale price:** \$ 1,625.00  
**Material:** Aluminum/Steel  
**Color:** Natural Aluminum / Black Accessories  
**Max. Capacity:** 1,000 lbs.  
**Weight:** 86 lbs.  
**Dimensions:** Upright L14 3/4" x W25 1/2" x H51 1/4"  
 On 4-Wheels L47 1/2" x W25 1/2" x H41 1/4"

**Requirements:** None

**Conflicts:** None

**Suggestions:** Mag Top Shelf Safety Lock Kit, Tripod Holder with 5/8" Baby Pin, Dove Tail Mount, Steadi-Cam Riser Unit, Mag Steadi-Cam Swing Handles, Mag Steadi-Cam Vest Holder



Magliner Junior (Modified) with 8" Wheel Conversion Kit (Narrow), Top and Bottom 18" wide Shelves, 30" HD Nose and SandDune Wheel Kit. Price as shown \$2,505.00



Magliner Junior (Modified) with 8" Wheel Conv. Kit, Top and Bottom 24" wide Shelves, 30" HD Nose, Tripod Holder with 5/8" Baby Pin, Mitchell Mount, Front Box & Battery Holder.

The Magliner Junior Modified Cart was made with the Camera Assistant, Sound, Photographer and Steadi-Cam Operator in mind. Some of the alterations we've made are the replacement of the 5" stock wheels with 8" pneumatics with brakes, custom Toe Plate, Nose and Frame re-enforcement, pre-drilled cart to accept all bolt-on accessories.

**Part No:** MAG-01 JR-8X 18 \$ 1,595.00 (Same as MAG-01 JR-8X 24 but equipped with 18" Wide Shelves and 8" Wheel Conversion Kit Narrow)

**Shipping Weight/Dims:** 92 lbs. (L16" x W26" x H45")



## Magliner Junior Modified with 10" Wheels



Magliner Junior (Modified) outfitted with 10" Wheel Conversion Kit (Standard), 24" wide Top Shelf, 24" wide Bottom Shelf and 30" HD Nose.

The Magliner Junior 10 is a modified Magliner, similar to the MAG-01 JR-08X 24 model, but equipped with 10" wheels all around. This cart breaks down by removing Top Shelf, lowering the 30" HD Nose and inserting the "U" Handle underneath the cart.



Close-up of 10" Wheel Conversion Kit



Close-up of Front Wheel Assembly

**Part No:** MAG-01 JR-10X 24  
**Sale price:** \$ 1,800.00 (as shown)  
**Material:** Aluminum/Steel  
**Color:** Natural Aluminum / Black Accessories  
**Max. Capacity:** 1000 lbs.  
**Weight:** 99 lbs.

**Shipping Weight/Dims:** 108 lbs. (L16" x W26" x H45")



**Dimensions:** Upright L17 1/2" x W26 1/2" x H51 1/2"  
On 4-Wheels L48 1/2" x W26 1/2" x H44 1/4"

**Magliner Senior Modified with 10" Wheels**

**Part No:** MAG-01 SR-10X 24  
**Sale price:** \$ 1,950.00

**Requirements:** None

**Conflicts:**

**Suggestions:** Mag Top Shelf Safety Lock Kit, Mag Mitchell Mount, Mag Tripod Holder with 5/8" Baby Pin, Mag Sand/Dune Wheel Kit, Mag Bag, Mag 35" Utility Box, Mag 3" Cable Holder, Mag 6" Cable Holder

## Magliner Senior (Modified)



Magliner Senior (Modified) outfitted with 8" Wheel Conversion Kit (Standard), Mag Senior 24" wide Top Shelf, Mag Senior 24" wide Bottom Shelf and 30" HD Nose.



Magliner Senior (Modified) outfitted with 8" Wheel Conversion Kit (Narrow), 18" wide Top Shelf, 18" wide Bottom Shelf and 30" HD Nose. Sale price \$ 1,725.00 (MAG-01 SR-8X 18)



Magliner Senior (Modified) with 8" Wheel Conversion Kit (Standard), 24" wide Top Shelf, 24" wide Bottom Shelf, 30" HD Nose, Twin Axle Wheel Kit, Dual Video Bracket, Grip/Light Caddy (Large), U-Handle 5/8" Baby Pin.

The Magliner Senior Modified Cart was modified with the Videographer and Camera Assistant in mind. Some of the alterations we've made are the replacement of the rear 5" stock wheels with 8" pneumatics with brakes, "U" Handle Bar outfitted with Grip Handles, Nose and Frame re-enforcement, cart is pre-drilled to accept all bolt-on accessories.



Magliner Senior (Modified) with 8" Dual Wheel Conversion Kit (Standard), 24" wide Top Shelf, 24" wide Bottom Shelf, 30" HD Nose, 3/4" Rear Axle (Quad), C-Stand Holder (4), Grip/Light Caddy (Large), Electric Stand Holder (Dual)

**Part No:** MAG-01 SR-8X 24

**Sale price:** \$ 1,775.00

**Material:** Aluminum/Steel

**Color:** Natural Aluminum / Black Accessories

**Max. Capacity:** 1,000 lbs.

**Weight:** 97 lbs.

**Dimensions:** Upright L14 3/4" x W25 1/2" x H64"

On 4-Wheels L60 1/4" x W25 1/2" x H41 1/4"

**Shipping Weight/Dims:** 105 lbs. (L16" x W26" x H58")



**Requirements:** None

**Conflicts:** None

**Suggestions:** Mag Top Shelf Safety Lock Kit, Mag Senior 18" wide Top & Bottom Shelves, Mag Grip/Light Caddy, Mag U-Handle 5/8" Baby Pin, Mag 48" Utility Box, Mag Jockey Box

## Mag 8" Wheel Conversion Kit (Standard)

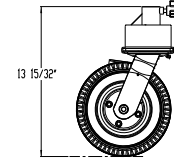
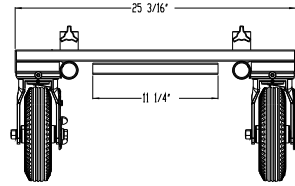
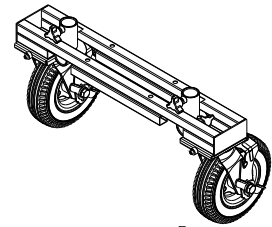
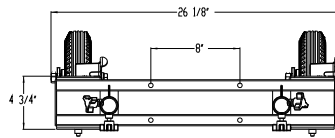

The Magliner 8" Wheel Conversion Kit (Standard) is still one of the favorites out in the Film and Video industry today. More and more technicians are adapting other type of wheels, such as the Sand/Dune Wheel Kit, and the Dual Wheels.

**Note: All Wheel Conversion Kits are now equipped with the wheel sliding bracket option which allows you to interchange between Sand/Dune Wheels and Dual Wheels.**

**Part No:** MAG-E  
**Sale price:** \$ 438.00  
**Material:** Steel  
**Color:** Black  
**Max. Capacity:** 500 lbs.  
**Weight:** 26 lbs.  
**Dimensions:** D4 3/4" x W25 3/16" x H13 1/2"

**Shipping Weight/Dims:** 29 lbs. (L29" x W17" x H8")



**Requirements:** Magliner Junior (Modified) or Magliner Senior (Modified)  
**Conflicts:** None  
**Suggestions:** Mag Sand/Dune Wheel Kit, Mag Dual Wheels. See other Mag 8" Conversion Kit options



## Mag 8" Wheel Conversion Kit (Narrow)

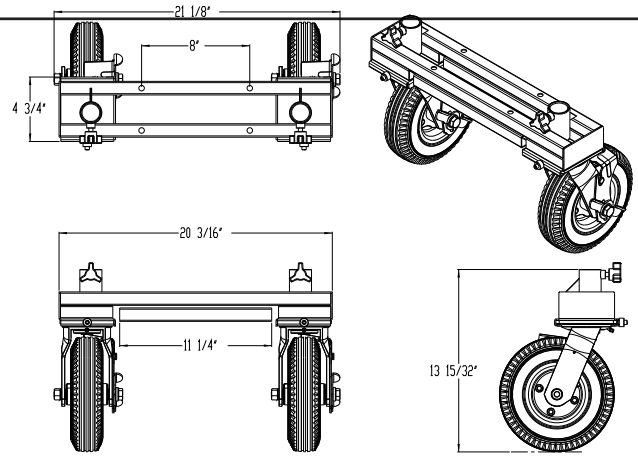

Specifically made to be used with 18 inch wide Shelves.

**Note: All Wheel Conversion Kits are now equipped with the wheel sliding bracket option which allows you to interchange between Standard Pneumatic Wheels, Sand/Dune Wheels and Dual Wheels.**

Part No: MAG-EN  
 Sale price: \$ 428.00  
 Material: Steel  
 Color: Black  
 Max. Capacity: 500 lbs.  
 Weight: 25 lbs.  
 Dimensions: D4 3/4" x W20 3/16" x H13 1/2"

Shipping Weight/Dims: 27 lbs. (L24" x W17" x H7")



Requirements: Magliner Junior (Modified) or Magliner Senior (Modified)  
 Conflicts: Mag Skateboard Wheel Kit  
 Suggestions: See other 8" Wheel Conversion Kit options.





## Mag 8" Wheel Conversion Kit with Dual Wheels

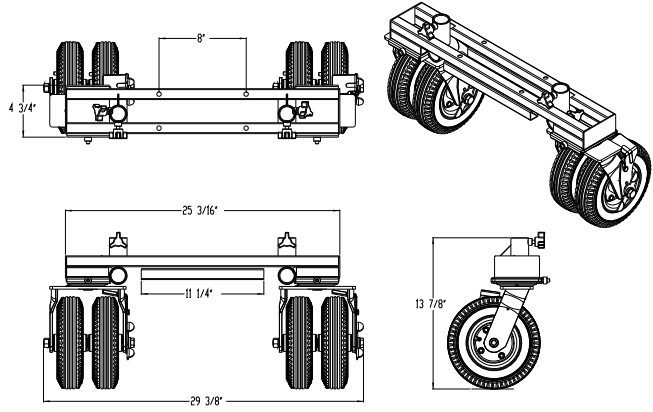

Same as the Standard Wheel Conversion Kit, but outfitted with four 8" wheels.  
**Note: All Wheel Conversion Kits are now equipped with the wheel sliding bracket option which allows you to interchange between Sand/Dune Wheels, Track Wheels and Dual Wheels.**

Part No: MAG-E4  
 Sale price: \$ 724.00  
 Material: Steel  
 Color: Black  
 Max. Capacity: 500 lbs.  
 Weight: 36 lbs.  
 Dimensions: D4 3/4" x W29 3/8" x H13 1/2"

Shipping Weight/Dims: 37 lbs. (L29" x W17" x H10")



Requirements: Magliner Junior (Modified) or Magliner Senior (Modified)  
 Conflicts: None  
 Suggestions: See other 8" Wheel Conversion Kit options, Mag Quad Axle Kit, Mag Twin Axle Kit, Mag Sand/Dune Wheel Kit



## Mag 30" HD Nose

Looks the same as the Stock model, but this nose has been modified. Nose Cross Bars are riveted on both sides and include Top Shelf Safety lock receivers. Unit comes pre-drilled to accept all accessories which bolt on to the 30" HD Nose, such as: Tripod Holder, Steadi-Cam Vest Holder, Mag Monitor Arm Nose Adapter and Nose 5/8" Baby Pins.

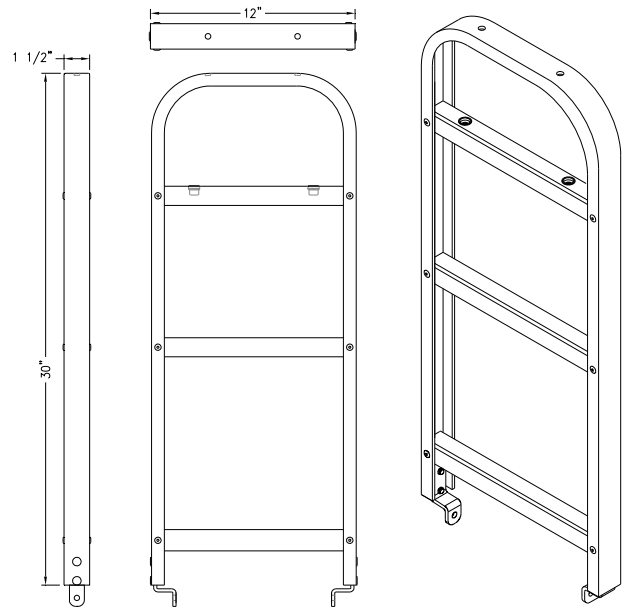

**Part No:** MAG-N HD30  
**Sale price:** \$ 114.00  
**Material:** Aluminum  
**Color:** Natural Aluminum  
**Max Capacity:** 400 lbs.  
**Weight:** 5 lbs.  
**Dimensions:** D1 1/2" x W12" x H30"

**Shipping Weight/Dims:** 6 lbs. (L3" x W14" x H31")



**Requirements:** Magliner Junior/Senior Cart (Stock or Modified)

**Conflicts:** None

**Suggestions:** Mag Tripod Holder with 5/8" Baby Pin, Mag Nose 5/8" Baby Pin (Ctr.), Mag Nose 5/8" Baby Pin (Offset), Mag Steadi-Cam Vest Holder, Mag Grip/Light Caddy

## Mag 30" HD Adjustable Nose

If you are planning to use a Middle Shelf, we highly recommend the 30" HD Adjustable Nose, you will have the ability to use up to seven different settings to control height positions. Top Nose Cross Bar and Adjustable Nose Cross Bar include Shelf Safety Lock receivers. Unit comes pre-drilled to accept all Nose accessories, such as: Tripod Holder, Steadi-Cam Vest Holder, Mag Monitor Arm Nose Adapter & Nose 5/8" Baby Pins.

**Note:** Middle Shelf requires a Mag U-Handle Cross Bar (MAG-CB LK AL) on the handle side of the cart to hold Middle Shelf in place, unit is also adjustable.

**Note:** If you need to use a Mag Middle Shelf and a Grip/Light Caddy or Photo Caddy at the same time, you will need to add an additional Adjustable Nose Cross Bar (MAG-NA CB-X)

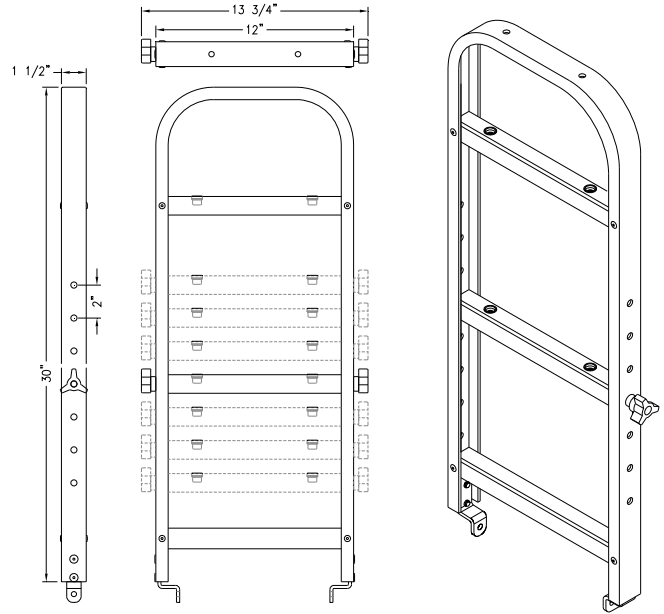

**Part No:** MAG-N HD30-A

**Sale price:** \$ 205.00

**Material:** Aluminum

**Color:** Natural Aluminum

**Max. Capacity:** 400 lbs.

**Weight:** 6 lbs.

**Dimensions:** D1 1/2" x W13 3/4" x H30"

**Shipping Weight/Dims:** 7 lbs. (D3" x W14" x H31")



**Mag U-Handle (Adjustable) Cross Bar**

**Part No:** MAG-CB LK AL

**Sale price:** \$ 135.00

**Mag (Adjustable) Nose Cross Bar**

**Part No:** MAG-NA CB-X

**Sale price:** \$ 95.00

**Requirements:** Magliner Mini, Magliner Junior/Senior (Modified)

**Conflicts:** Mag Grip/Light Caddy (Large), Mag Grip/Light Caddy (Small), Mag Photo Caddy

**Suggestions:** Mag Middle Shelf, Mag U-Handle Cross Bar with Lock, Mag Nose 5/8" Pin (Ctr.), Mag Nose 5/8" Pin (Offset), Mag Nose 5/8" Pin (Dual), Mag Nose 5/8" Pin (Side)

## Mag 40" HD Nose

The 40" Heavy Duty Nose is a custom made accessory which will add 10 inches of height to your Magliner Cart. Nose Cross Bars are riveted on both sides and include Top Shelf Safety lock receivers. Unit comes pre-drilled to accept all accessories which bolt on to the 40" HD Nose, such as: Tripod Holders, Steadi-Cam Vest Holder, Mag Monitor Arm, Nose Adapter and Nose 5/8" Baby Pins.

**Note: Cart must be equipped with a Mag 40" U-Handle Bar (with handles) on rear side to compensate for height difference.**  
(Part number MAG-HU SR-X Sale price \$ 165.00)

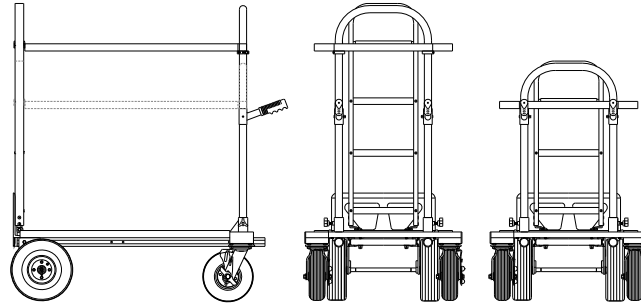

Mag Junior with 40" HD Nose and 40" U-Handle

Mag Junior with 30" HD Nose

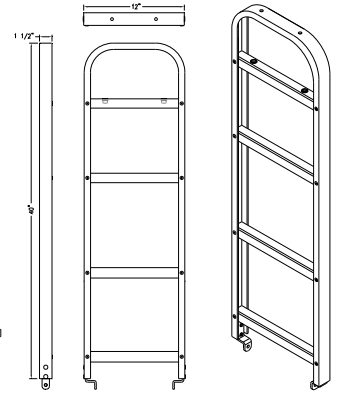

**Part No:** MAG-N HD40  
**Sale price:** \$ 225.00  
**Material:** Aluminum  
**Color:** Natural Aluminum  
**Max. Capacity:** 400 lbs.  
**Weight:** 5 lbs.  
**Dimensions:** D1 1/2" x W12" x H40"

**Shipping Weight/Dims:** 8 lbs. (D3" x W14" x H41")



**Requirements:** Magliner Junior (Modified), Magliner Senior (Modified), Mag 40" U-Handle Bar, Clamp-on Collar (2)

**Conflicts:** None

**Suggestions:** Mag Tripod Holder with 5/8" Baby Pin, Mag Nose Pin (Ctr.), Mag Nose Pin (Offset), Mag Nose Pin (Side), Mag Steadi-Cam Vest Holder, Mag Grip/Light Caddy

## Mag 40" HD Adjustable Nose

If you are planning to use a Middle Shelf, we highly recommend the 40" HD Adjustable Nose, you will have the ability to use up to twelve different settings to control height positions. Top Nose Cross Bar and Adjustable Nose Cross Bar include Shelf Safety Lock receivers. Unit comes pre-drilled to accept all Nose accessories, such as: Tripod Holder, Steadi-Cam Vest Holder, Mag Monitor Arm Nose Adapter & Nose 5/8" Baby Pins.

**Note:** Middle Shelf requires a Mag U-Handle Cross Bar (MAG-CB LK AL) on the handle side of the cart to hold Middle Shelf in place, unit is also adjustable.

**Note:** If you need to use a Mag Middle Shelf and a Grip/Light Caddy or Photo Caddy at the same time, you will need to add an additional Adjustable Nose Cross Bar (MAG-NA CB-X)

**Note:** Cart must be equipped with a Mag 40" U-Handle Bar (with handles) on rear side to compensate for height difference. (Part number MAG-HU SR-X Sale price \$ 205.00)

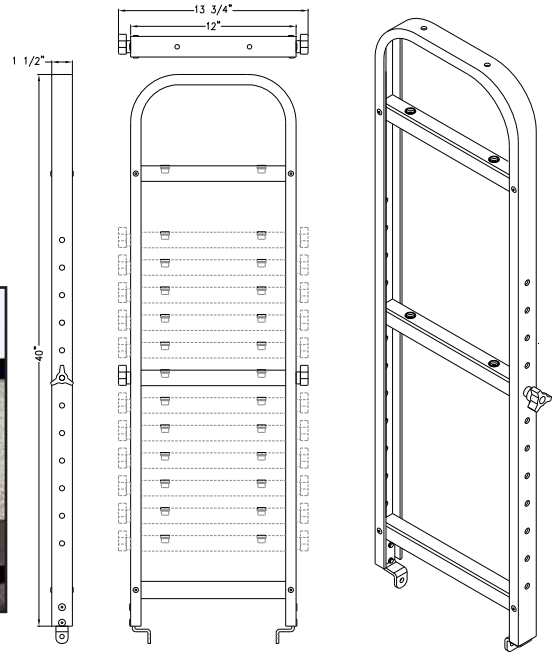
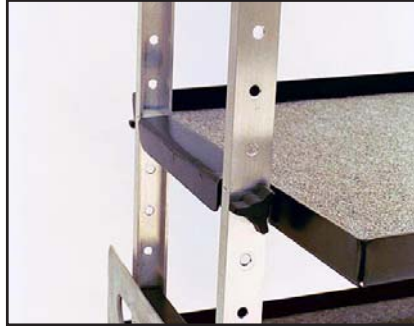

**Part No:** MAG-N HD40-A  
**Sale price:** \$ 325.00  
**Material:** Aluminum  
**Color:** Natural Aluminum  
**Max. Capacity:** 400 lbs.  
**Weight:** 6 lbs.  
**Dimensions:** D1 1/2" x W13 3/4" x H40"

**Shipping Weight/Dims:** 9 lbs. (D3" x W14" x H41")



**Mag U-Handle (Adjustable) Cross Bar**  
**Part No:** MAG-CB LK AL  
**Sale price:** \$ 135.00

**Mag (Adjustable) Nose Cross Bar**  
**Part No:** MAG-NA CB-X  
**Sale price:** \$ 95.00

**Requirements:** Magliner Junior (Modified), Magliner Senior (Modified), Mag 40" U-Handle Bar

**Conflicts:** Mag Grip/Light Caddy (Large), Mag Grip/Light Caddy (Small), Mag Photo Caddy

**Suggestions:** Mag Middle Shelf, Mag U-Handle Cross Bar with Lock, Mag Tripod Holder, Mag Nose Pin (Ctr.), Mag Nose Pin (Offset), Mag Nose Pin (Side)

## Mag Snap-On Lap Top Tray with Air Vent

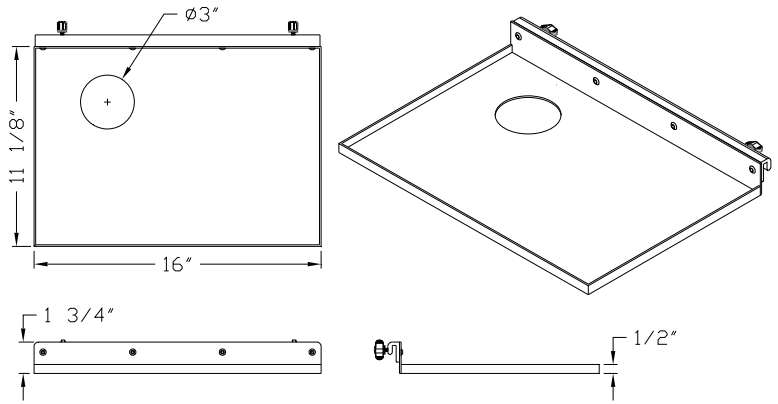

The Mag Lap Top Snap-On Tray was specifically made to hold the Apple Lap Tops. It snaps into any Magliner Shelf by using its built-in lip. The Tray has a 5/16" lip all around that will not interfere with computer's cables or input/output devices. The Tray is carpeted and has a three inch vent hole to dissipate heat.

**Part No:** MAG-LTM  
**Sale price:** \$ 165.00  
**Material:** Aluminum  
**Color:** Black  
**Max. Capacity:** 20 lbs.  
**Weight:** 3 lbs.  
**Dimensions:** D11 5/8" x W16" x H1 1/4"

**Shipping Weight/Dims:** 4 lbs. (L20" x W13" x H3")



Mag Snap-On Lap Top Tray shown with Apple Mac Pro 17" Hard Shell Case

**Requirements:** Mag Top Shelf

**Conflicts:**

**Suggestions:** Mag Lap Top Tray Offset Arm, Mag Lap Top Tray Swing Arm, Mag U-Handle Offset Baby Pin, Mag LCD HD Monitor Arm, Mag HD Tent

## Mag Lap Top Tray

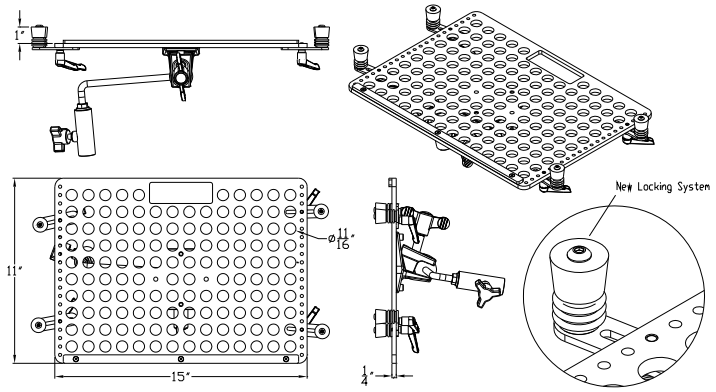

The Lap Top Tray is made of 1/4" aluminum with 11/16" holes every one inch to help dissipate heat away from your Lap Top. Includes an opening in the rear to run your cables through, it has four separate adjusting safety locking clamps and a stop bar at the bottom of the tray to secure your Lap Top. Tray has an adjustable swivel mechanism that enables you to position your Lap Top at any angle. It comes with a 5/8" baby receiver that will fit into any standard 5/8" Baby Pin device.



Lap Top Tray shown with Swing Arm Deluxe and U-Handle Offset 5/8" Baby Pin

**Part No:** MAG-LTP

**Sale price:** \$ 475.00

**Material:** Aluminum

**Color:** Red Anodize

**Max. Capacity:** 20 lbs.

**Weight:** 4 lbs.

**Dimensions:** D11" x W15" x H5"

**Shipping Weight/Dims:** 5 lbs. (L16" x W13" x H5")



**Requirements:** Any Mag accessory or device with a standard 5/8" Baby Pin

**Conflicts:**

**Suggestions:** Mag Swing Arm, Mag Swing Arm Deluxe, Mag Offset Arm, Mag U-Handle 5/8" Baby Pin, Mag U-Handle Offset 5/8" Baby Pin, Mag Nose 5/8" Pin (Center)

# Mag Swing Arm

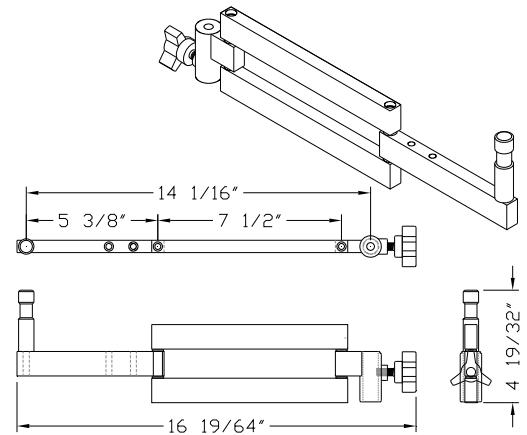

Mag Swing Arm shown with Mag iPad Holder

**Part No:** MAG-LTA  
**Sale price:** \$ 165.00  
**Material:** Aluminum  
**Color:** Natural Aluminum  
**Max. capacity:** 30 lbs.  
**Weight:** 2 lbs.

**Shipping Weight/Dims:** 2 lbs. (L11" x W7" x H5")



**Dimensions:** L16 3/8" x W1 7/8" x H4 5/8" (Extended)  
 L8" x W3 1/2" x H4 5/8" (Folded)

**Requirements:** Any Mag accessory or devise with with a standard 5/8" Baby Pin

**Conflicts:** None

**Suggestions:** Mag Lap Top Tray, Mag U-Handle Center 5/8" Baby Pin, Mag U-Handle Offset 5/8" Baby Pin, Mag Nose 5/8" Baby Pin (Center), Mag Nose 5/8" Baby Pin (Side)



## Mag Swing Arm (Small)

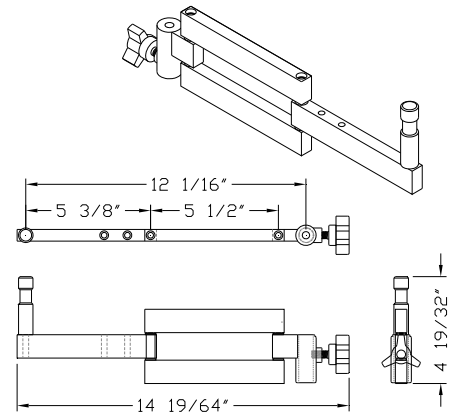
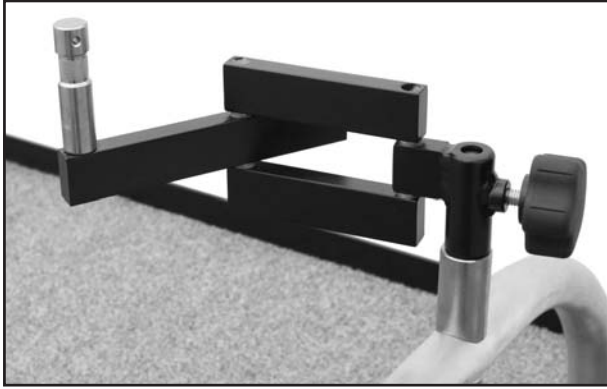

**Part No:** MAG-LTA SM

**Sale price:** \$ 155.00

**Material:** Aluminum

**Color:** Black

**Max. capacity:** 30 lbs.

**Weight:** 2 lbs.

**Dimensions:** L14 3/8" x W1 7/8" x H4 5/8" (Extended)  
L6" x W3 1/2" x H4 5/8" (Folded)

**Shipping Weight/Dims:** 2 lbs. (L10" x W7" x H3")



**Requirements:** Any Mag accessory or device with with a standard 5/8" Baby Pin

**Conflicts:** None

**Suggestions:** Mag LCD Tilt Head, Mag LCD 4"/6"/8" Tilt Head Adapter, Mag U-Handle Center 5/8" Baby Pin, Mag U-Handle Offset 5/8" Baby Pin, Mag Nose 5/8" Baby Pins

## Mag Offet Arm



The new Mag Offet Arm has been totally redesigned. It's now a one piece aluminum part with the capacity to install 5/8" Baby Pin in three different points. We have also made it possible to either use a prong on the left or right side.

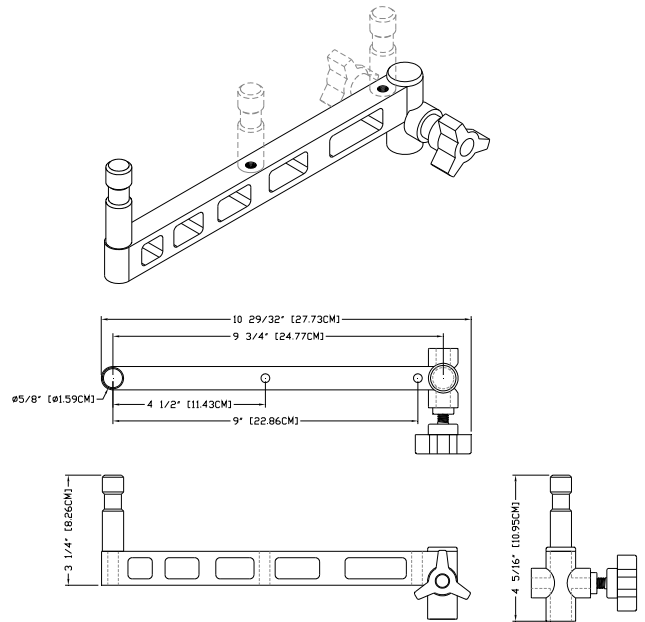

**Part No:** MAG-V OS  
**Sale price:** \$225.00  
**Material:** Aluminum  
**Color:** Black  
**Max. capacity:** 30 lbs.  
**Weight:** 1 lbs.  
**Dimensions:** L10 3/16" x W2 3/8" x H5 1/2"

**Shipping Weight/Dims:** 2 lbs. (L5" x W5" x H13")



**Requirements:** Any Mag accessory or devise with with a standard 5/8" Baby Pin

**Conflicts:** None

**Suggestions:** Mag LCD Tilt Head, Mag U-Handle Center 5/8" Baby Pin, Mag U-Handle Offset 5/8" Baby Pin, Mag Nose 5/8" Baby Pin (Center, Offset, Dual or Side)

## Mag Nose Loading Handles



The Mag Nose Loading Handle is an excellent accessory to have around when you need someone to help you lift and carry your Magliner. The Loading Handles are easily attached to any 30" Mag Nose. The height can be adjusted for correct lifting posture.

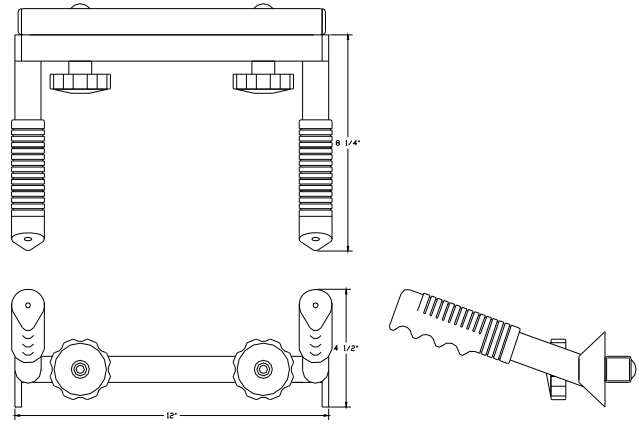

**Part No:** MAG-HN  
**Sale price:** \$ 151.00  
**Material:** Steel  
**Color:** Black  
**Max. Capacity:** 150 lbs.  
**Weight:** 3 lbs.  
**Dimensions:** D10" x W12 3/8" x H5"

**Shipping Weight/Dims:** 4 lbs. (L12" x W11" x H4")



**Requirements:** Mag 30" Nose, Mag Top Shelf  
**Conflicts:** Mag Grip/Light Caddy, Mag Photo Caddy  
**Suggestions:**



## Mag Junior 24" Top Shelf

Top Shelf is pre-drilled to accept Mag Top Shelf Safety Lock system, Mag Sound Tray (Left or Right side), Mag Sliding Drawer with Lock (2-Space, 3-Space, 4-Space), Mag LCD Monitor Arm (Light Duty, Medium Duty, Heavy Duty).

**Part No:** MAG-CA JR  
**Sale price:** \$265.00  
**Material:** Aluminum  
**Color:** Black  
**Max. Capacity:** 200 lbs.  
**Weight:** 15 lbs.  
**Dimensions:** L40" x W24 1/4" x 2 1/4"  
 (ID L36 1/4" x W24" x H1")

**Shipping Weight/Dims:** 17 lbs. (L41" x W25" x H3")

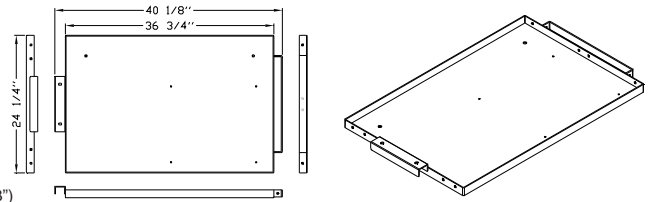

**Requirements:** Magliner Junior (Stock) or Magliner Junior (Modified), Mag 30" Nose (Heavy Duty)  
**Conflicts:** None  
**Suggestions:** Mag Top Shelf Safety Pin and Prong, Mag Junior Sound Tray (Collapsible), Mag Junior 24" Bottom Shelf

## Mag Junior 18" Top Shelf

Top Shelf is pre-drilled to accept Mag Top Shelf Safety Lock system, Mag Sound Tray (Left or Right side), Mag Sliding Drawer with Lock (2-Space, 3-Space, 4-Space), Mag LCD Monitor Arm (Light Duty, Medium Duty, Heavy Duty).

**Part No:** MAG-C JR  
**Sale price:** \$255.00  
**Material:** Aluminum  
**Color:** Black  
**Max. Capacity:** 200 lbs.  
**Weight:** 12 lbs.  
**Dimensions:** L40" x W18 1/4" x 2 1/4"  
 (ID L36 1/4" x W18" x H1")

**Shipping Weight/Dims:** 14 lbs. (L41" x W19" x H3")

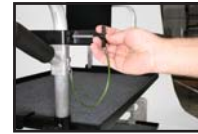
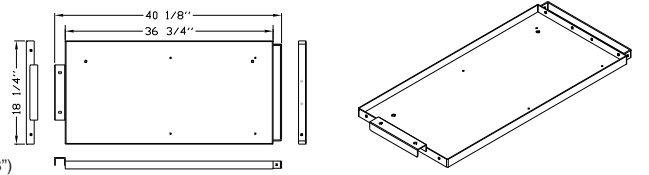

Optional Mag Top Shelf Safety Pin and Prongs (See page 47)

**Requirements:** Magliner Junior (Stock) or Magliner Junior (Modified), Mag 30" Nose (Heavy Duty)  
**Conflicts:** None  
**Suggestions:** Mag Top Shelf Safety Pin and Prong, Mag Junior Sound Tray (Collapsible), Mag Junior 18" Bottom Shelf, Mag Junior 18" Middle Shelf

## Mag Junior 24" Top Shelf Keyboard Friendly

Same as the standard Mag 24" Top Shelf, but no lip on left side to allow you to use a keyboard or tablet without interfering with your arm. Pre-drilled to hold Monitor Arm at either end.

**Note: Sound Tray may only be installed on right side of Top Shelf.**

**Part No:** MAG-CA JR KB

**Sale price:** \$275.00

**Material:** Aluminum

**Color:** Black

**Max. Capacity:** 200 lbs.

**Weight:** 15 lbs.

**Dimensions:** L40" x W24 1/4" x H 2 1/4"  
(ID L36 1/4" x W24" x H1")

**Shipping Weight/Dims:** 17 lbs. (L41" x W25" x H3")



Optional Mag Top Shelf Safety Pin & Prongs (See page 47)

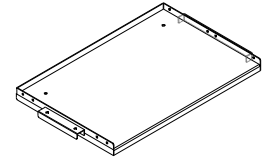
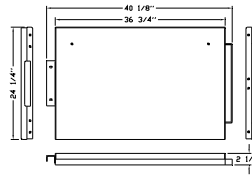

**Requirements:** Magliner Junior (Stock) or Magliner Junior (Modified), Mag 30" Nose (Heavy Duty)

**Conflicts:** Mag Keyboard Tray, Mag Keyboard & Mouse Tray, Mag Drawer with lock, Mag Snap-On Lap Top Tray

**Suggestions:** Mag Top Shelf Safety Pin and Prong, Mag Junior Sound Tray (Collapsible), Mag Junior 24" Bottom Shelf

## Mag Junior 18" Top Shelf Keyboard Friendly

Same as the standard Mag 18" Top Shelf, but no lip on left side to allow you to use a keyboard or tablet without interfering with your arm. Pre-drilled to hold Monitor Arm either end.

**Note: Sound Tray may only be installed on right side of Top Shelf.**

**Part No:** MAG-C JR KB

**Sale price:** \$265.00

**Material:** Aluminum

**Color:** Black

**Max. Capacity:** 200 lbs.

**Weight:** 12 lbs.

**Dimensions:** L40" x W18 1/4" x H 2 1/4"  
(ID L36 1/4" x W18" x H1")

**Shipping Weight/Dims:** 14 lbs. (L41" x W19" x H3")

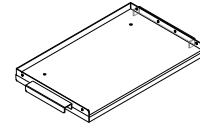
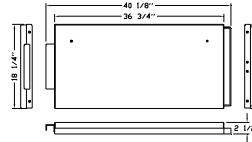

**Requirements:** Magliner Junior (Stock) or Magliner Junior (Modified), Mag 30" Nose (Heavy Duty)

**Conflicts:** Mag Keyboard Tray, Mag Keyboard & Mouse Tray, Mag Drawer with lock, Mag Snap-On Lap Top Tray

**Suggestions:** Mag Top Shelf Safety Pin and Prong, Mag Junior Sound Tray (Collapsible), Mag Junior 24" Bottom Shelf, Mag Junior 24" Middle Shelf

## Mag Junior 24" Middle Shelf

Standard Middle Shelves have the same receiver bracket at each end. One end hooks to the Nose, the other hooks to the Mag U-Handle Cross Bar.

**Note:** Middle Shelf requires a Mag U-Handle Cross Bar (MAG-CB LK AL) on the handle side of the cart to hold Middle Shelf in place, unit is also adjustable.

Part No: MAG-CA JR-M

Sale price: \$ 285.00

Material: Aluminum

Color: Black

Max. Capacity: 200 lbs.

Weight: 15 lbs.

Dimensions: L40" x W24 1/4" x 2 1/4"  
(ID L36 1/2" x W24" x H1")

Shipping Weight/Dims: 17 lbs. (L41" x W25" x H3")

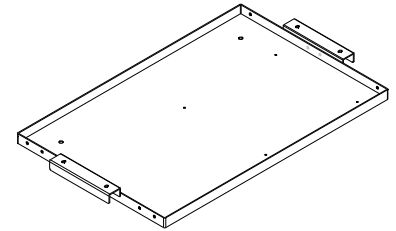
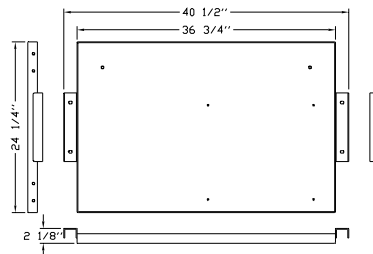

Mag U-Handle (Adjustable) Cross Bar

Part No: MAG-CB LK AL

Sale price: \$ 135.00

**Requirements:** Magliner Junior (Modified or Stock), Mag 30" HD Nose, Mag 30" HD Adjustable Nose (recommended), Mag Cross Bar with lock

**Conflicts:** Mag Grip/Light Caddy (Large), Mag Grip/Light Caddy (Small), Mag Photo Caddy

**Suggestions:** Mag Junior Sound Tray (Collapsible)



## Mag Junior 18" Middle Shelf

Standard Middle Shelves have the same receiver bracket at each end. One end hooks to the Nose, the other hooks to the Mag U-Handle Cross Bar.

**Note:** Middle Shelf requires a Mag U-Handle Cross Bar (MAG-CB LK AL) on the handle side of the cart to hold Middle Shelf in place, unit is also adjustable.

Part No: MAG-C JR-M

Sale price: \$ 275.00

Material: Aluminum

Color: Black

Max. Capacity: 200 lbs.

Weight: 12 lbs.

Dimensions: L40" x W18 1/4" x 2 1/4"  
(ID L36 1/2" x W18" x H1")

Shipping Weight/Dims: 14 lbs. (L41" x W19" x H3")

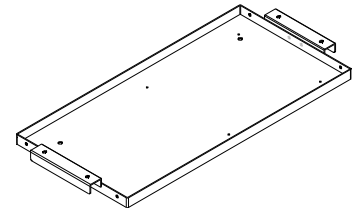
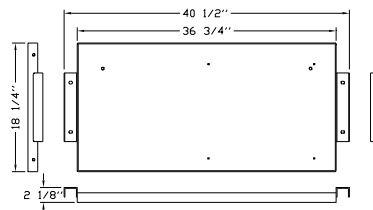

Mag U-Handle (Adjustable) Cross Bar

Part No: MAG-CB LK AL

Sale price: \$ 135.00

**Requirements:** Magliner Junior (Stock) or Magliner Junior (Modified), Mag 30" HD Adjustable Nose (recommended), Mag Cross Bar with lock

**Conflicts:** Mag Grip/Light Caddy (Large), Mag Grip/Light Caddy (Small), Mag Photo Caddy

**Suggestions:** Mag Junior Sound Tray (Collapsible)

## Mag Junior 24" Bottom Shelf

Part No: MAG-DA JR  
Sale price: \$ 245.00  
Material: Aluminum  
Color: Black  
Max. Capacity: 600 lbs.  
Weight: 14 lbs.

Shipping Weight/Dims: 16 lbs. (L41" x W25" x H3")



Dimensions: L36 7/8" x W24 1/4" x 1 3/8"  
(ID L36 5/8" x W24" x H1")

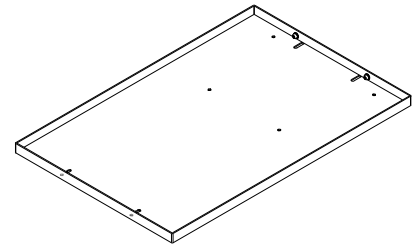
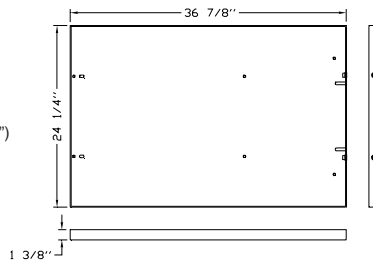

Requirements: Magliner Junior (Stock) or Magliner Junior (Modified)

Conflicts: None

Suggestions:

## Mag Junior 18" Bottom Shelf

Part No: MAG-D JR  
Sale price: \$ 235.00  
Material: Aluminum  
Color: Black  
Max. Capacity: 600 lbs.  
Weight: 11 lbs.

Shipping Weight/Dims: 14 lbs. (L41" x W19" x H3")



Dimensions: L36 7/8" x W18 1/4" x 1 3/8"  
(ID L36 5/8" x W18" x H1")

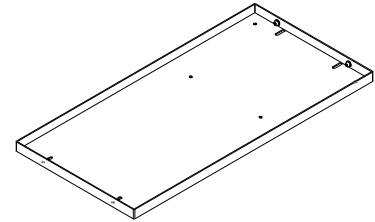
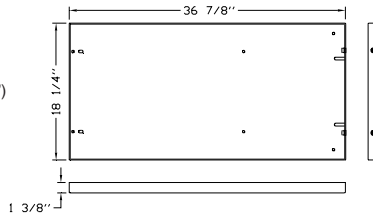

Requirements: Magliner Junior (Stock) or Magliner Junior (Modified)

Conflicts: None

Suggestions:

## Mag Junior 24" Bottom Alum. Plate

Part No: MAG-DA JR AP  
Sale price: \$ 305.00  
Material: Aluminum  
Color: Black  
Max. Capacity: 600 lbs.  
Weight: 21 lbs.  
Dimensions: L35 1/4" x W24" x 1/4"

Shipping Weight/Dims: 16 lbs. (L36" x W25" x H3")  

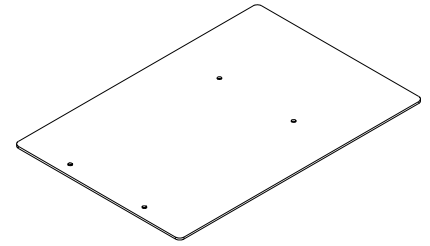
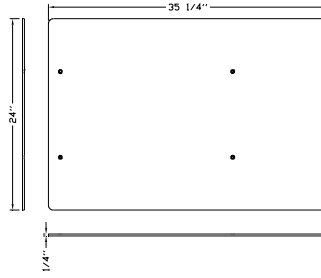

Requirements: Magliner Junior (Stock) or Magliner Junior (Modified)  
Conflicts: None  
Suggestions:

## Mag Junior 18" Bottom Alum. Plate

Part No: MAG-D JR AP  
Sale price: \$ 278.00  
Material: Aluminum  
Color: Black  
Max. Capacity: 600 lbs.  
Weight: 16 lbs.  
Dimensions: L35 1/4" x W18" x 1/4"

Shipping Weight/Dims: 14 lbs. (L36" x W19" x H3")  

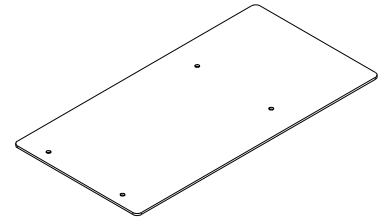
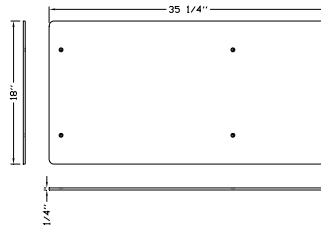

Requirements: Magliner Junior (Stock) or Magliner Junior (Modified)  
Conflicts: None  
Suggestions:



## Mag Junior Sound Tray (Collapsible)



Sound Tray secures itself to an 18" or 24" Mag Junior Top Shelf with hand prongs. Sound Tray is fully collapsible. Sound Tray may be used on right or left side of Shelf.

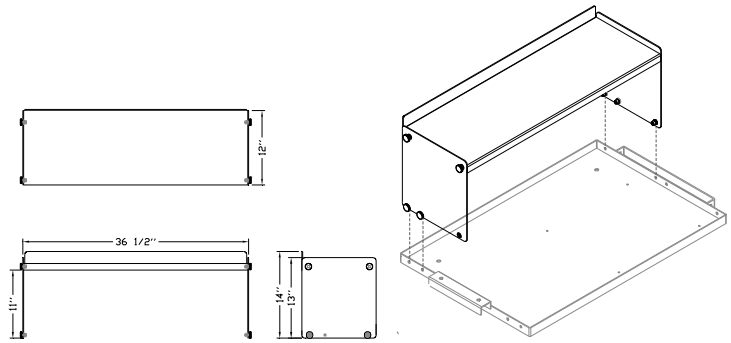

Mag Sound Tray with Mag 24" Top Shelf

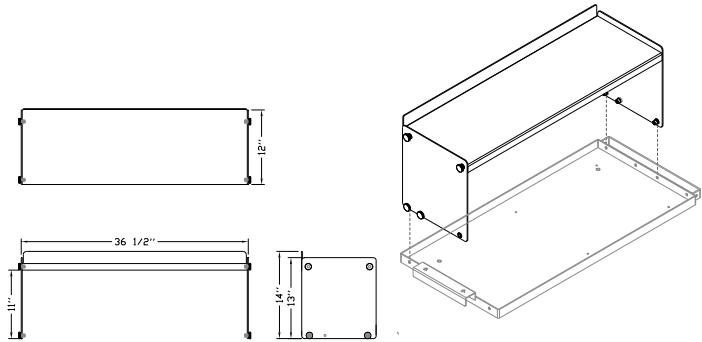

Mag Sound Tray with Mag 18" Top Shelf

**Part No:** MAG-F JR  
**Sale price:** \$ 305.00  
**Material:** Aluminum, Gray Carpet  
**Color:** Black  
**Max. Capacity:** 100 lbs.  
**Weight:** 13 lbs.  
**Dimensions:** D12" x W36 1/2" x H14"

**Shipping Weight/Dims:** 14 lbs. (L36" x W13" x H5")



**Requirements:** Mag Junior 24" Top Shelf or Mag Junior 18" Top Shelf

**Conflicts:** Mag Tripod Holder with 5/8" Baby Pin , Mag Nose 5/8" Baby Pin (Ctr.), Mag U-Handle 5/8" Baby Pin, Mag Mitchell Mount, Mag Dove Tail Mount

**Suggestions:** Mag Top Shelf Safety Lock Pin and Prong, Mag Mic Boom Grip & Base, Mag Nose 5/8" Baby Pin (Offset), Mag Nose 5/8" Baby Pin (Side)

# Mag Junior Sound Tray Double Decker (Collapsible)



Sound Tray secures itself to an 18" or 24" Mag Junior Top Shelf with hand prongs. Sound Tray is fully collapsible. Sound Tray may be used on right or left side of shelf.

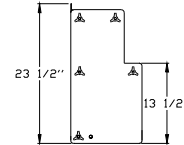
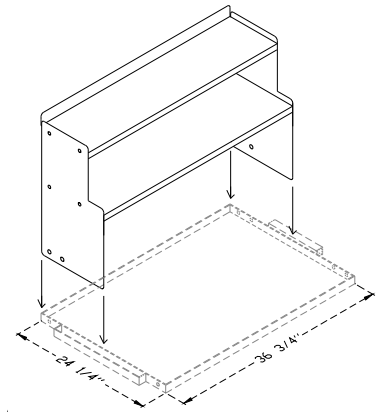
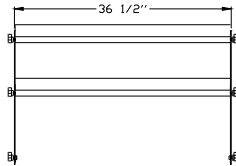
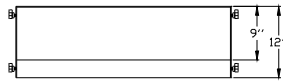

**Part No:** MAG-F JR-DD  
**Sale price:** \$525.00  
**Material:** Aluminum, Gray Carpet  
**Color:** Black  
**Max. Capacity:** 100 lbs.  
**Weight:** 22 lbs.  
**Dimensions:** D12" x W36 1/2" x H23 1/2"

**Shipping Weight/Dims:** 24 lbs. (L36" x W13" x H5")



**Requirements:** Mag Junior 24" Top Shelf or Mag Junior 24" Top Shelf  
**Conflicts:** Tripod Holder with 5/8" Baby Pin, Mag Nose 5/8" Baby Pin (Ctr.), Mag U-Handle 5/8" Baby Pin, Mag Mitchell Mount, Mag Dove Tail Mount  
**Suggestions:** Mag Top Shelf Safety Lock Pin & Prong, Mag Mic Boom Grip & Base, Mag Nose 5/8" Baby Pin (Offset), Mag U-Handle 5/8" Offset Baby Pin, Mag Utility Box, Mag 3" Cable Holder

## Mag Senior 24" Top Shelf (Stock)

The Magliner Senior Stock model does not come equipped with Grip Handles as the Junior model. Because of this, we can't use the drop-and-lock system. The Stock Shelf uses a male prong to lock in place. The prong goes through the Magliner U-Handle and locks into a custom rivet nut built into the shelf itself. (See picture below)

**Part No:** MAG-CA SR-S

**Sale price:** \$320.00

**Material:** Aluminum

**Color:** Black

**Max. Capacity:** 200 lbs.

**Weight:** 19 lbs.

**Dimensions:** L51 1/4" x W24 1/4" x H2 1/8"  
(ID L49 1/4" x W24" x H1")

**Shipping Weight/Dims:** 22 lbs. (L54" x W25" x H3")

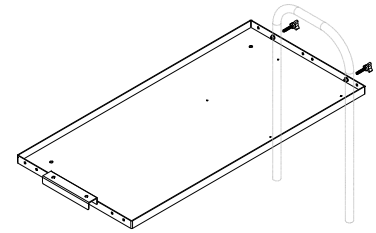
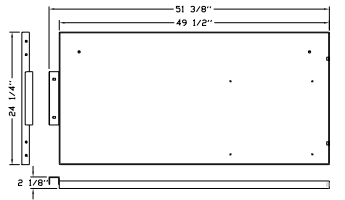

**Requirements:** Magliner Senior (Stock), Mag 30" Nose, Mag 30" Nose (Heavy Duty)

**Conflicts:** Mag Sound Tray, Mag Ditty Bag, Mag Mitchell Mount, Mag Dove Tail Mount, Mag Euro Ball Mount 150mm, Mag Euro Ball Mount 100mm, Mag Euro Ball Mount 75mm

**Suggestions:** Mag Senior 24" Bottom Shelf

## Mag Senior 18" Top Shelf (Stock)

The Magliner Senior Stock model does not come equipped with Grip Handles as the Junior model. Because of this, we can't use the drop-and-lock system. The Stock Shelf uses a male prong to lock in place. The prong goes through the Magliner U-Handle and locks into a custom rivet nut built into the shelf itself. (See picture above)

**Part No:** MAG-C SR-S

**Sale price:** \$300.00

**Material:** Aluminum

**Color:** Black

**Max. Capacity:** 200 lbs.

**Weight:** 15 lbs.

**Dimensions:** L51 1/4" x W18 1/4" x H2 1/8"  
(ID L49 1/4" x W18" x H1")

**Shipping Weight/Dims:** 18 lbs. (L54" x W19" x H3")

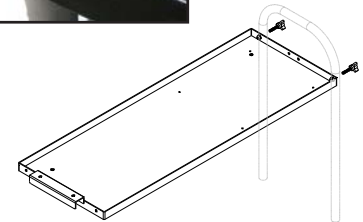
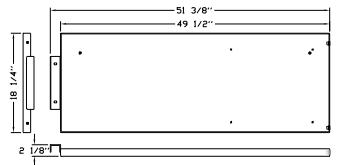

**Requirements:** Magliner Senior (Stock)

**Conflicts:** Mag Sound Tray, Mag Ditty Bag, Mag Mitchell Mount, Mag Dove Tail Mount, Mag Euro Ball Mount 150mm, Mag Euro Ball Mount 100mm, Mag Euro Ball Mount 75mm

**Suggestions:** Mag Senior 18" Bottom Shelf

## Mag Senior 24" Top Shelf

Top Shelf is pre-drilled to accept Mag Top Shelf Safety Lock system, Mag Sound Tray (Left or Right side), Mag Sliding Drawer with Lock (2-Space, 3-Space, 4-Space), Mag LCD Monitor Arm (Light Duty, Medium Duty, Heavy Duty).

**Part No:** MAG-CA SR

**Sale price:** \$330.00

**Material:** Aluminum

**Color:** Black

**Max. Capacity:** 200 lbs.

**Weight:** 19 lbs.

**Dimensions:** L52 7/8" x W24 1/4" x 2 1/8"  
(ID L49 1/2" x W24" x H1")

**Requirements:** Magliner Senior (Modified), Mag 30" Nose (Heavy Duty)

**Conflicts:** None

**Suggestions:** Mag Top Shelf Safety Pin and Prong, Mag Senior Sound Tray (Collapsible), Mag Senior 24" Bottom Shelf

**Shipping Weight/Dims:** 22 lbs. (L54" x W25" x H3")

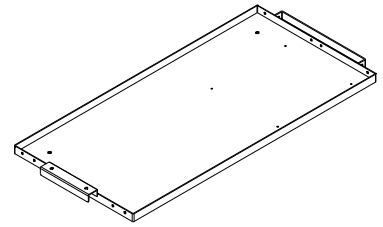
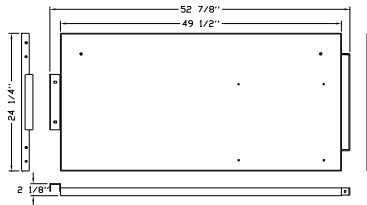

## Mag Senior 18" Top Shelf

Top Shelf is pre-drilled to accept Mag Top Shelf Safety Lock system, Mag Sound Tray (Left or Right side), Mag Sliding Drawer with Lock (2-Space, 3-Space, 4-Space), Mag LCD Monitor Arm (Light Duty, Medium Duty, Heavy Duty).

**Part No:** MAG-C SR

**Sale price:** \$310.00

**Material:** Aluminum

**Color:** Black

**Max. Capacity:** 200 lbs.

**Weight:** 16 lbs.

**Dimensions:** L52 7/8" x W18 1/4" x 2 1/8"  
(ID L49 1/4" x W18" x H1")

**Requirements:** Magliner Senior (Modified), Mag 30" Nose (Heavy Duty)

**Conflicts:** None

**Suggestions:** Mag Top Shelf Safety Pin and Prong, Mag Senior Sound Tray (Collapsible), Mag Senior 18" Bottom Shelf, Mag Mic Boom Grip & Base

**Shipping Weight/Dims:** 18 lbs. (L54" x W19" x H3")

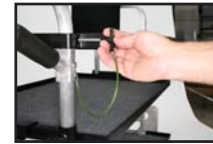
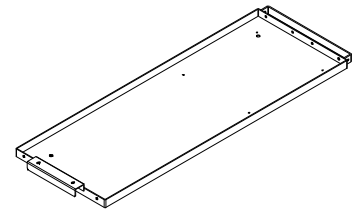
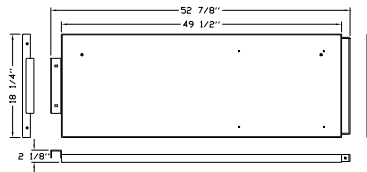

Optional Mag Top Shelf Safety Pin and Prongs (See page 47)

## Mag Senior 24" Middle Shelf

Standard Middle Shelves have the same receiver bracket at each end. One end hooks to the Nose, the other hooks to the Mag U-Handle Cross Bar.

**Note:** Middle Shelf requires a Mag U-Handle Cross Bar (MAG-CB LK AL) on the handle side of the cart to hold Middle Shelf in place, unit is also adjustable.

**Part No:** MAG-CA SR-M

**Sale price:** \$ 350.00

**Material:** Aluminum

**Color:** Black

**Max. Capacity:** 200 lbs.

**Weight:** 19 lbs.

**Dimensions:** L52 3/4" x W24 1/4" x H2 1/4"  
(ID L49 1/4" x W24" x H1")

**Shipping Weight/Dims:** 22 lbs. (L54" x W25" x H3")

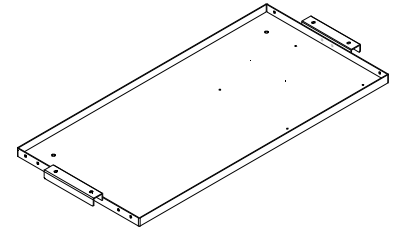
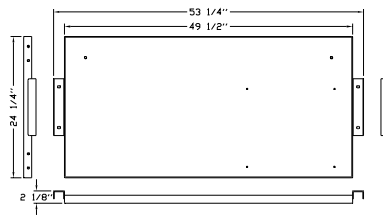

**Mag U-Handle (Adjustable) Cross Bar**

**Part No:** MAG-CB LK AL

**Sale price:** \$ 135.00

**Requirements:** Magliner Senior (Modified), Mag 30" Nose (Heavy Duty/Adjustable), Mag U-Handle Cross Bar

**Conflicts:** Mag Grip/Light Caddy

**Suggestions:** Mag Senior Sound Tray (Collapsible)



## Mag Senior 18" Middle Shelf

Standard Middle Shelves have the same receiver bracket at each end. One end hooks to the Nose, the other hooks to the Mag U-Handle Cross Bar.

**Note:** Middle Shelf requires a Mag U-Handle Cross Bar (MAG-CB LK AL) on the handle side of the cart to hold Middle Shelf in place, unit is also adjustable.

**Part No:** MAG-C SR-M

**Sale price:** \$ 330.00

**Material:** Aluminum

**Color:** Black

**Max. Capacity:** 200 lbs.

**Weight:** 15 lbs.

**Dimensions:** L52 3/4" x W18 1/4" x H2 1/4"  
(ID L49 1/4" x W18" x H1")

**Shipping Weight/Dims:** 18 lbs. (L54" x W19" x H3")

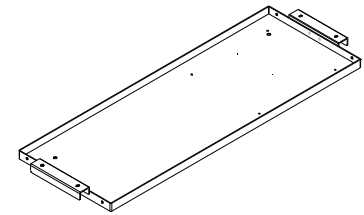
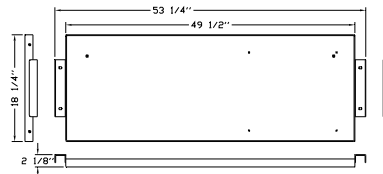

**Mag U-Handle (Adjustable) Cross Bar**

**Part No:** MAG-CB LK AL

**Sale price:** \$ 135.00

**Requirements:** Magliner Senior (Stock) or Magliner Senior (Modified), Mag 30" Nose (Heavy Duty/Adjustable), Mag U-Handle Cross Bar

**Conflicts:** Mag Grip/Light Caddy

**Suggestions:** Mag Senior Sound Tray (Collapsible)

## Mag Senior 24" Bottom Shelf

Part No: MAG-DA SR  
Sale price: \$310.00  
Material: Aluminum  
Color: Black  
Max. Capacity: 600 lbs.  
Weight: 18 lbs.

Shipping Weight/Dims: 21 lbs. (L54" x W25" x H3")

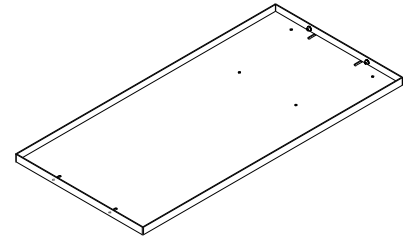
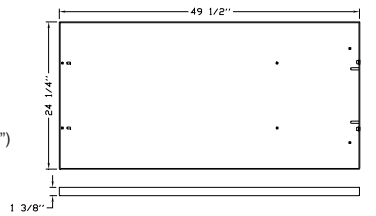

Dimensions: L49 1/2" x W24 1/4" x H1 3/8"  
(ID L49 1/4" x W24" x H1")

Requirements: Magliner Senior (Stock) or Magliner Senior (Modified)

Conflicts: None

Suggestions:

## Mag Senior 18" Bottom Shelf

Part No: MAG-D SR  
Sale price: \$290.00  
Material: Aluminum  
Color: Black  
Max. Capacity: 600 lbs.  
Weight: 15 lbs.

Shipping Weight/Dims: 17 lbs. (L54" x W19" x H3")

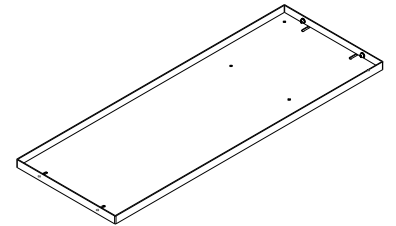
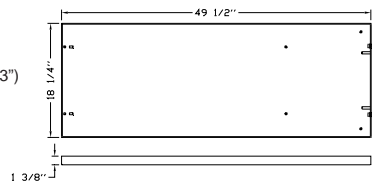

Dimensions: L49 1/2" x W18 1/4" x H1 3/8"  
(ID L49 1/4" x W18" x H1")

Requirements: Magliner Senior (Stock) or Magliner Senior (Modified)

Conflicts: None

Suggestions:

## Mag Senior Sound Tray (Collapsible)



Sound Tray secures itself to 24" or 18" Mag Senior Top Shelf with three prongs. Sound Tray is fully collapsible. Sound Tray may be used on right or left side of shelf.

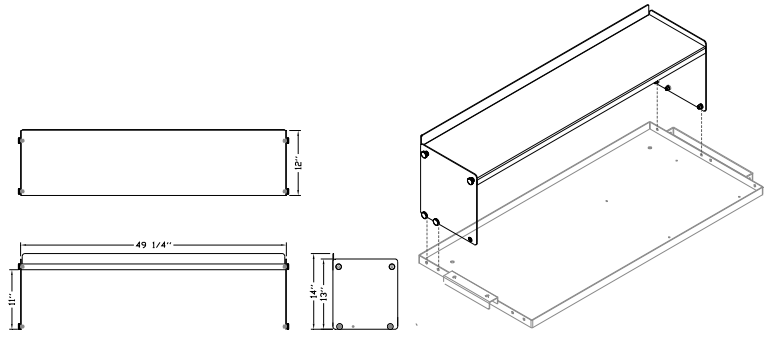

Mag Senior Sound Tray with Mag 24" Top Shelf

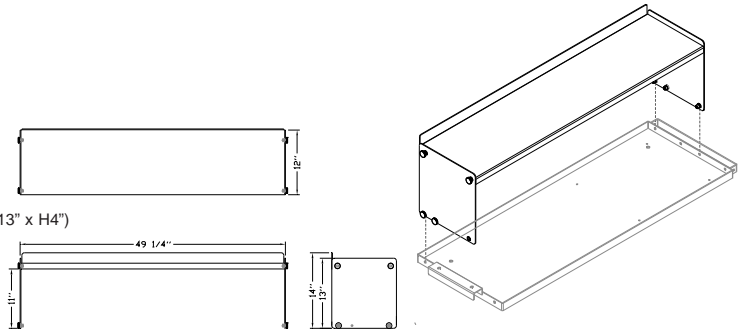

Mag Senior Sound Tray with Mag 18" Top Shelf

**Part No:** MAG-F SR  
**Sale price:** \$ 355.00  
**Material:** Aluminum, Gray Carpet  
**Color:** Black  
**Max. Capacity:** 100 lbs.  
**Weight:** 14 lbs.  
**Dimensions:** D12" x W49 1/4" x 14"

**Shipping Weight/Dims:** 18 lbs. (L50" x W13" x H4")



**Requirements:** Mag Senior 24" Top Shelf or Mag Senior 18" Top Shelf

**Conflicts:** Mag Tripod Holder with 5/8" Baby Pin, Mag Nose 5/8" Baby Pin (Ctr.), Mag U-Handle 5/8" Baby Pin, Mag Mitchell Mount, Mag Dove Tail Mount

**Suggestions:** Mag Top Shelf Safety Lock Pin and Prong, Mag Mic Boom Grip & Base, Mag Nose 5/8" Baby Pin (Offset), Mag Nose 5/8" Baby Pin (Side), Mag U-Handle 5/8" Baby Offset Pin

## Mag Top Shelf Safety Lock Kit



Mag Top Shelf Safety Lock and Prong secures Top Shelf from tilting sideways, specially useful when using Mag Sound Tray or Monitor Arms attached to Top Shelf. Kit includes (2) T- Aircraft Pin with 12" lanyard and (2) locking prongs. Note: If your Magliner Top Shelf and U-Handle are already pre-drilled, you can install this kit by yourself.

**Part No:** MAG-CA SL KIT

**Sale price:** \$ 65.00

**Material:** Aluminum/Steel

**Color:** Black

**Max. Capacity:** N/A

**Weight:** 1 lb.

**Dimensions:** L3 1/2" x W2" x H1/2" / Diam. 1 3/8" x H1 1/2"

**Requirements:** Pre-drilled Top Shelf, Mag U-Handle & Mag Nose HD

**Conflicts:**

**Suggestions:**

**Shipping Weight/Dims:** 1 lb. (L9" x W5" x H3")



Note: If your Magliner U-Handle and Top Shelf do not have existing holes (old models), you can have the Top Shelf Mag Safety Lock system installed by us. Price includes labor and all necessary parts and hardware.

**Part No:** MAG-CA SL

**Sale price:** \$ 130.00





## Mag U-Handle Detachable Cross Bar with Lock



The new version allows you to detach your Mag Cross Bar from the U-Handle without having to disassemble your cart. Unit uses two collars with hinges to grab on to U-Handle for a 360 degree tight fit without damaging U-Handle, a hex wrench is required.

Must be installed when using a Middle Shelf on a modified Magliner. Unit can be adjusted at any height within the U-Handle. This feature will allow the user to set the Middle Shelf at different heights.

**Note: Must have Mag 30" or 40" HD Adjustable Nose on the other side to make this possible.**

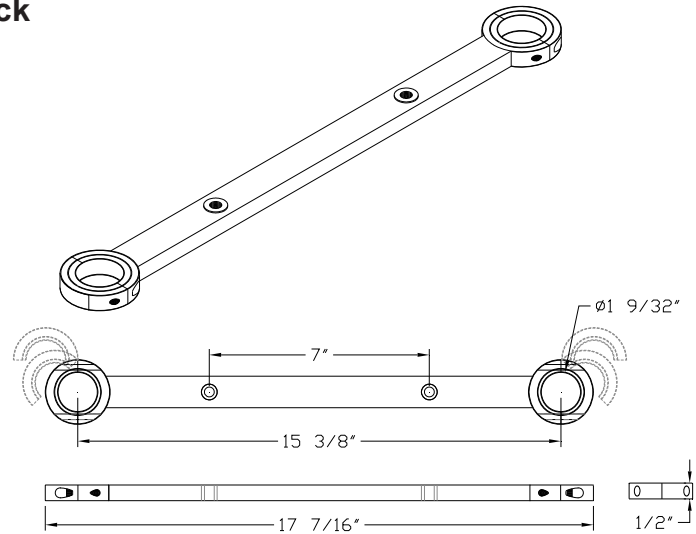

**Part No:** MAG-CB LK AL

**Sale price:** \$ 135.00

**Material:** Steel

**Color:** Black

**Max. Capacity:** 200 lbs.

**Weight:** 1 lb.

**Dimensions:** D2" x W17 7/16" x H1/2"

**Shipping Weight/Dims:** 2 lbs. (L4" x W4" x H19")



**Requirements:** Stock Magliner, Modified Magliner

**Conflicts:** None

**Suggestions:** Mag Middle Shelf, Mag Sound Tray, Mag Mic Boom Grip & Base, Mag 2-Space Roller Sliding Drawer with Lock, Mag Cable Holders, Mag Headphone Holder

## Mag Tripod Holder with 5/8" Baby Pin

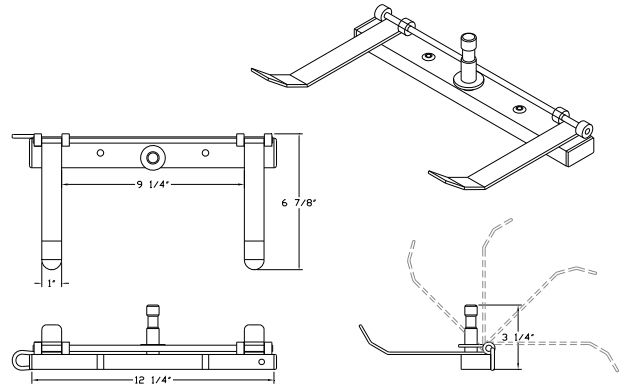

The Mag Tripod Holder can hold two full size Tripods, a rubber bungee secures Tripods in place. The built-in 5/8" Baby Pin can accept anything with a 5/8" receiver, such as an Umbrella Holder or a Mag Dual Video Bracket. The Tripod Holder can be flipped 180 degrees so it lays down flat when Nose is folded.



Mag Umbrella Holder attached to Mag Tripod Pin



Mag Tripod Pin in fold-down position

**Part No:** MAG-TP  
**Sale price:** \$ 185.00  
**Material:** Steel  
**Color:** Black  
**Max. Capacity:** 100 lbs.  
**Weight:** 3 lbs.  
**Dimensions:** D6 3/4" x W13 3/4" x H3 1/4"

**Shipping Weight/Dims:** 4 lbs. (L14" x W8" x H5")



**Requirements:** Mag 30" Nose (Heavy Duty)

**Conflicts:** Mag Sound Tray, Mag Nose 5/8" Baby Pin (Ctr.), Mag Nose 5/8" Baby Pin (Offset), Mag Steadi-Cam Vest Holder, Mag LCD HD Monitor Arm Nose Adapter

**Suggestions:** Mag Umbrella Holder, Mag Umbrella, Mag Dual Video Monitor Bracket

## Mag Mitchell Mount

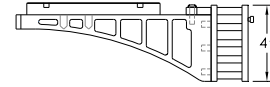
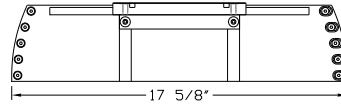
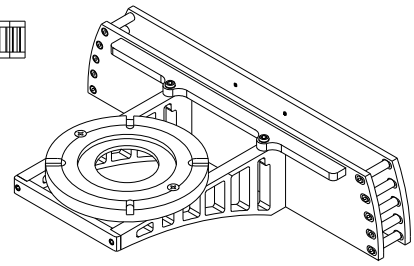
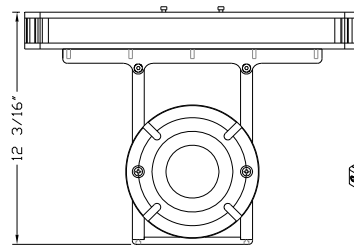

Mitchell Mount with all aluminum construction. Unit will accommodate any 16 or 35 mm camera fully equipped. Unit can be mounted towards the front or rear of cart. It comes equipped with universal front box mounting screws.

**Mag Mitchell plate (MAG-M PL) can be purchased separately for \$ 80.00 dollars.**

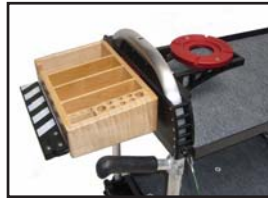

**Part No:** MAG-M AL  
**Sale price:** \$400.00  
**Material:** Aluminum  
**Color:** Black/Red Anodize (Plate)  
**Max. Capacity:** 200 lbs.  
**Weight:** 8 lbs.  
**Dimensions:** D12 1/4" x W16 7/8" x H4 1/8"

**Shipping Weight/Dims:** 10 lbs. (L19" x W15" x H5")



**Requirements:** Mag Top Shelf (Mini, Junior or Senior, 18" or 24")  
**Conflicts:** Mag Bag  
**Suggestions:** Mag Dove Tail Mount, Mag Front Box, Mag Ditty Bag



## Mag Dove Tail Mount

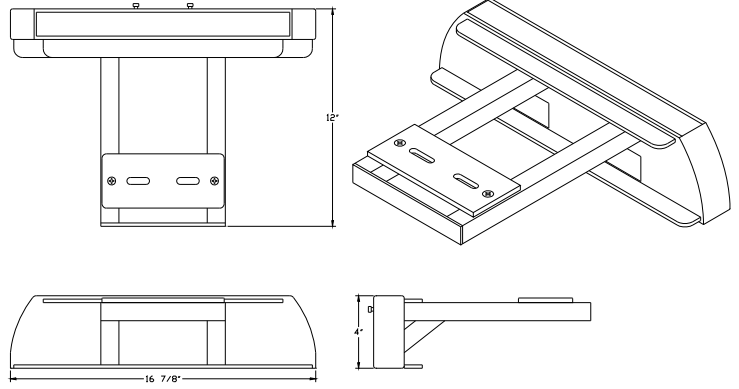

The Mag Dove Tail Mount comes equipped with the Mag Universal Dove Tail Plate, unit will accommodate any Quick Release Plate. Unit can be mounted towards the front or rear of cart. It comes equipped with universal Front Box mounting screws.

**Note: Mag Dove Tail Plate (MAG-DT PL) can be purchased separately for \$ 60.00 dollars**



**Part No:** MAG-DT AL  
**Sale price:** \$ 380.00  
**Material:** Aluminum  
**Color:** Black/Red Anodize (Plate)  
**Max. Capacity:** 200 lbs.  
**Weight:** 9 lbs.  
**Dimensions:** D12 1/4" x W16 7/8" x H4"

**Shipping Weight/Dims:** 13 lbs. (L19" x W15" x H5")



**Requirements:** Mag Top Shelf (Mini, Junior or Senior, 18" or 24")  
**Conflicts:** Mag Bag  
**Suggestions:** Mag Mitchell Mount, Mag Front Box, Mag Ditty Bag

## Mag Euroball Mount (150mm)

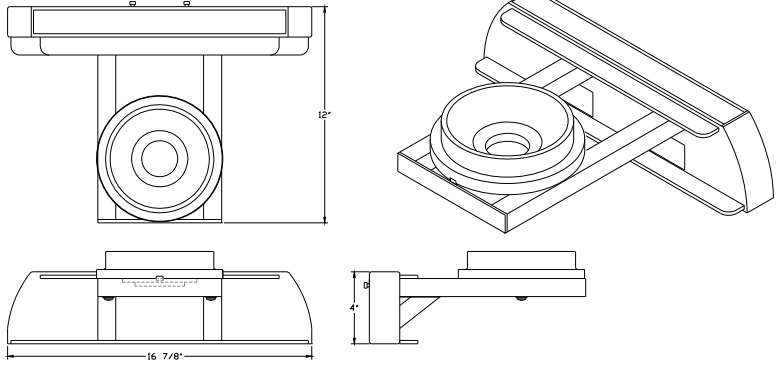

The Mag 150mm Euro Ball Mount comes equipped with the Mag 150mm Plate. Unit can be mounted towards the front or rear of cart. It comes equipped with universal Front Box mounting screws.

**Note: Mag Euroball plate (MAG-EU PL 150) can be purchased separately for \$ 150.00 dollars. It adapts to any standard Mitchell plate.**

**Part No:** MAG-EU 150 AL

**Sale price:** \$ 470.00

**Material:** Aluminum

**Color:** Black/Red Anodize (Plate)

**Max. Capacity:** 200 lbs.

**Weight:** 13 lbs.

**Dimensions:** L12 1/4" x W16 7/8" x H5 1/8"

**Shipping Weight/Dims:** 14 lbs. (L19" x W15" x H5")



**Requirements:** Mag Top Shelf (Mini, Junior or Senior, 18" or 24")

**Conflicts:** Mag Bag

**Suggestions:** Mag Mitchell Mount, Mag Front Box, Mag Ditty Bag

## Mag Euroball Mount (100mm)

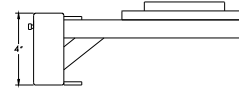
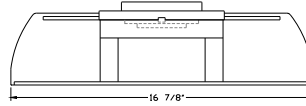
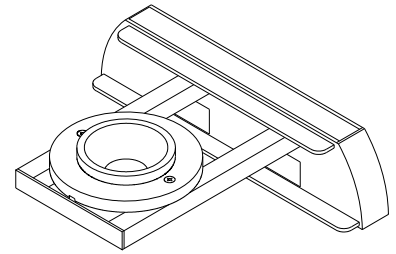
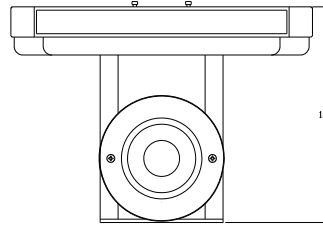

The Mag 100mm Euro Ball Mount comes equipped with the Mag 100mm Plate. Unit can be mounted towards the front or rear of cart. It comes equipped with universal Front Box mounting screws.

**Note: Mag Euroball plate (MAG-EU PL 100) can be purchased separately for \$ 130.00 dollars. It adapts to any standard Mitchell plate.**

**Part No:** MAG-EU 100 AL

**Sale price:** \$450.00

**Material:** Aluminum

**Color:** Black/Red Anodize (Plate)

**Max. Capacity:** 200 lbs.

**Weight:** 13 lbs.

**Dimensions:** L12 1/4" x W16 7/8" x H4 5/8"

**Shipping Weight/Dims:** 13 lbs. (L19" x W15" x H5")



**Requirements:** Mag Top Shelf (Mini, Junior or Senior, 18" or 24")

**Conflicts:** Mag Bag

**Suggestions:** Mag Mitchell Mount, Mag Front Box, Mag Ditty Bag

## Mag Euroball Mount (75mm)

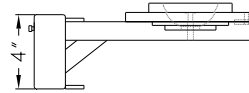
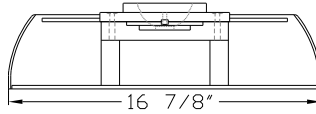
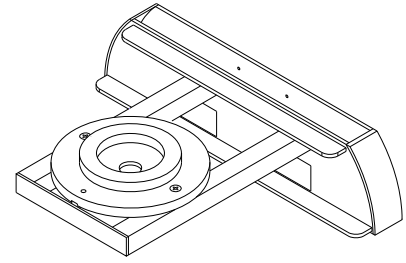
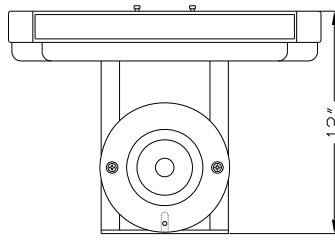

The Euroball Mount 75mm will accommodate any video or digital photographic camera fully equipped. Unit can be mounted towards the front or rear of cart. It comes equipped with universal front box mounting screws.

**Note: Mag Euroball plate (MAG-EU PL 75) can be purchased separately for \$ 120.00 dollars**

**Part No:** MAG-EU 75 AL  
**Sale price:** \$ 440.00  
**Material:** Aluminum  
**Color:** Black/Red Anodize (Plate)  
**Max. Capacity:** 200 lbs.  
**Weight:** 14 lbs.  
**Dimensions:** D12 1/2" x W17" x H4 1/2"

**Shipping Weight/Dims:** 15 lbs. (L19" x W15" x H5")



**Requirements:** Mag Top Shelf (Mini, Junior or Senior, 18" or 24")

**Conflicts:** Mag Bag

**Suggestions:** Mag Euroball Plate (150mm), Mag Euroball Plate (100mm), Mag Dove Tail Plate, Mag Mitchell Plate, Mag Front Box, Mag Ditty Bag, Mag HD Tent

# Mag Fluid Head Nose Mount Bracket

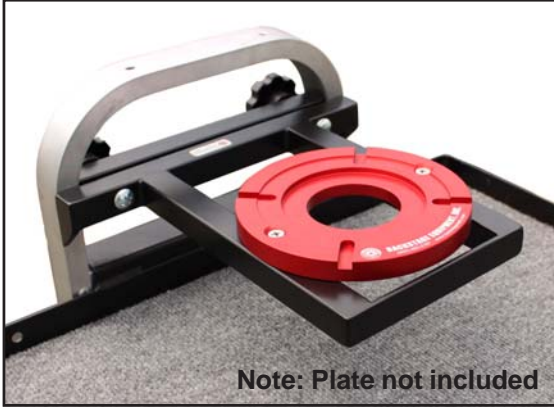

**Note: Plate not included**

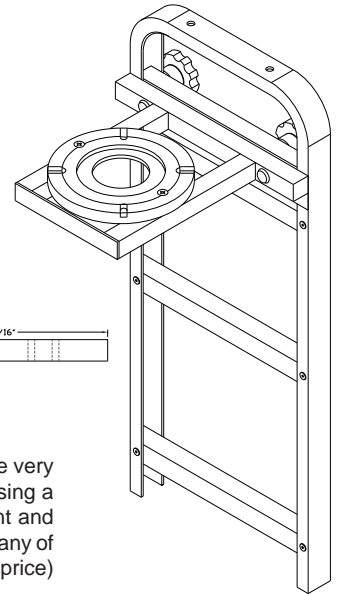
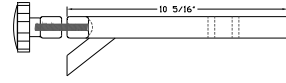
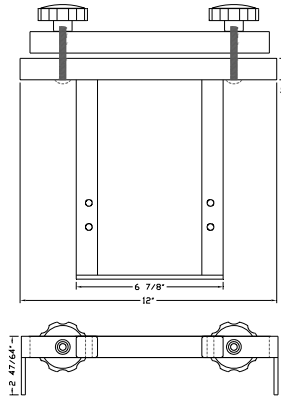

The Mag Fluid Head Nose Mount allows you to mount a Fluid Head on the Nose side of the cart, this will become very helpful when you need additional space and the ability to secure the unit, much more effective and safe than using a traditional Hi Hat or Low Hat. Mount may be mounted towards the inside or outside of Nose, height adjustment and removal can easily be done by loosening two hand prongs. Mount has universal hole pattern to allow you to install any of the following plates: Mitchell, Dove Tail, Euro Ball Plate 75mm, 100mm, 150mm. (see below for part number and price)

## Note: Plate not included

**Part No:** MAG-N FH  
**Sale price:** \$ 225.00  
**Material:** Steel  
**Color:** Black  
**Max. Capacity:** 75 lbs.  
**Weight:** 4 lbs.  
**Dimensions:** D12 1/2" x W17" x H4 1/2"

**Shipping Weight/Dims:** 5 lbs. (L16" x W13" x H5")



<b>MAG-M PL</b>	Mag Mitchell Plate	\$ 80.00
<b>MAG-DT PL</b>	Mag Dove Tail Plate	\$ 60.00
<b>MAG-EU PL 75</b>	Mag 75mm Euro Plate	\$ 120.00
<b>MAG-EU PL 100</b>	Mag 100mm Euro Plate	\$ 130.00
<b>MAG-EU PL 150</b>	Mag 150mm Euro Plate	\$ 150.00

**Requirements:** Mag 30" HD Nose, Mag 18" or 24" Top Shelf

**Conflicts:**

**Suggestions:** Hi-Lo Hat Holder, Mag Euroball Plate (150mm), Mag Euroball Plate (100mm), Mag Euroball Plate (75mm), Mag Dove Tail Plate, Mag Mitchell Plate, Mag DIT HD Tent



## Mag Front Box

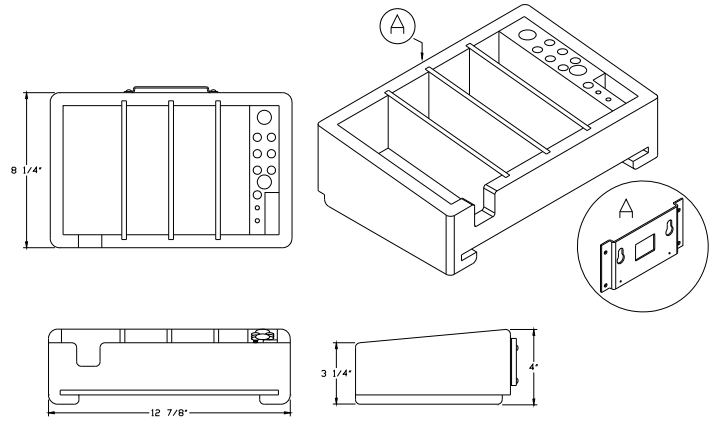
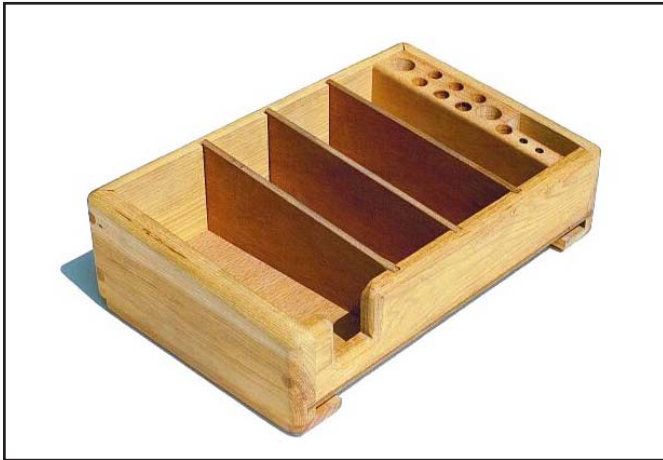

Mag Front Box comes with Front Box Mounting Bracket (see picture A) Front Box can be mounted to Mag Mitchell Mount, Mag Dove Tail Mount, Mag Front Box Adapter and Mag Skateboard Dolly Nose. Holds slate in special state holder area underneath Front Box. Dividers may be removed.

**Part No:** MAG-FB

**Sale price:** \$ 265.00

**Material:** Wood

**Color:** Natural Wood

**Max. Capacity:** 20 lbs.

**Weight:** 4 lbs.

**Dimensions:** D8 1/4" x W12 7/8" x H4"

**Shipping Weight/Dims:** 5 lbs. (L15" x W11" x H5")



**Requirements:** Mag Mitchell/Dove Tail or Euroball Mount, Mag Front Box Adapter

**Conflicts:** None

**Suggestions:** Mag Tripod Holder with 5/8" Baby Pin, Mag Utility Box, Mag Hi/Lo Hat Holder, Mag Drawer w/ Lock



## Mag Front Box Adapter

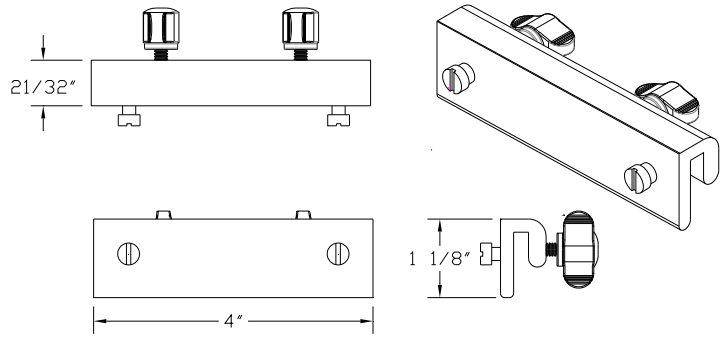

If you don't have a Mitchel or Dove Tail Mount, you can use this accessory to hold your Front Box. It hangs from the edge of your Top Shelf and can be set up anywhere around the Shelf.

**Part No:** MAG-FB A  
**Sale price:** \$ 48.00  
**Material:** Aluminum  
**Color:** Black  
**Max. Capacity:** 20 lbs.  
**Weight:** 1 lb.  
**Dimensions:** D3/4" x W4" x H1"

**Shipping Weight/Dims:** 1 lb. (L9" x W5" x H3")



**Requirements:** Mag Top Shelf (Junior or Senior, 18" or 24")  
**Conflicts:** None  
**Suggestions:** Mag Front Box, Mag Ditty Bag



Front Box Adapter with Front Box anchored to Top Shelf

## Mag Hi/Lo Hat Holder

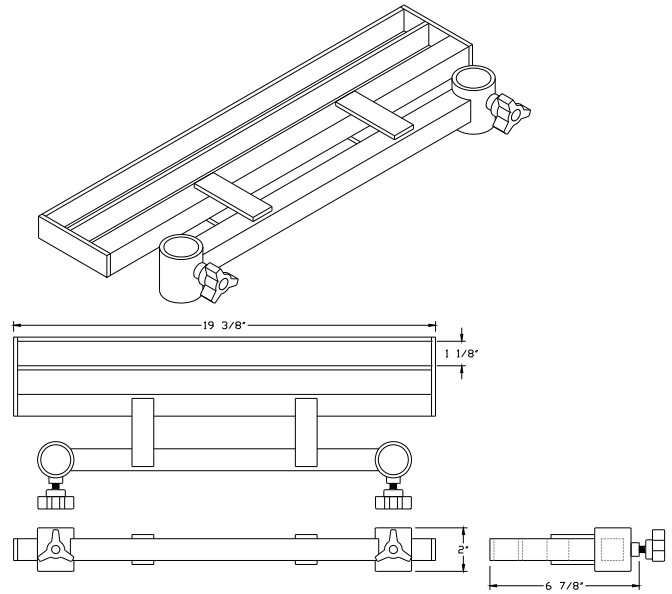
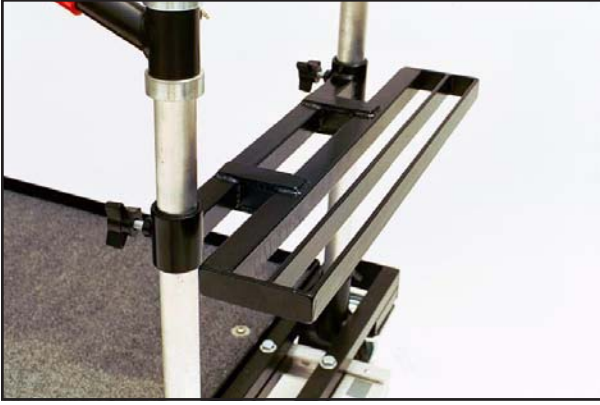

**Part No:** MAG-O  
**Sale price:** \$ 225.00  
**Material:** Steel  
**Color:** Black  
**Max. Capacity:** 50 lbs.  
**Weight:** 6 lbs.  
**Dimensions:** D7 1/2" x W19 3/8" x H2"

**Shipping Weight/Dims:** 7 lbs. (L20" x W10" x H3")



**Requirements:** Magliner Junior (Modified) or Magliner Senior (Modified)  
**Conflicts:** Mag Bag, Mag Ditty Bag, Mag C-Stand Holder (4)  
**Suggestions:** Mag Fluid Head Nose Mount Bracket, Mag Tripod Holder with 5/8" Baby Pin

## Mag Steadi-Cam Riser Unit



Optional Swing Handles (MAG-HS)

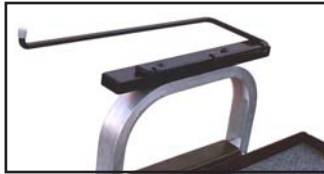

Optional Vest Holder (MAG-SV)

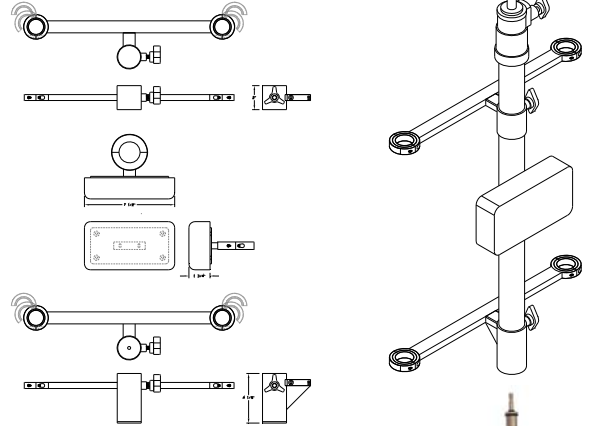

The Mag Steadi-Cam Riser Unit is a complete package which includes a Riser which can be adjusted from 42" up to 63" from floor. The Bumper's height can be adjusted as well as rotated. Unit also includes a Top and Bottom Bracket to keep everything locked in place. This unit was made and tested with the help of many well known Steadi-Cam operators. We're sure this accessory will benefit others.

**Part No:** MAG-SPR  
**Sale price:** \$ 575.00  
**Material:** Steel  
**Color:** Nickle Plate and Black  
**Max. Capacity:** 100 lbs.  
**Weight:** 12 lbs.  
**Dimensions:** D4 1/2" x L17 1/2" x H33"

**Shipping Weight/Dims:** 15 lbs. (L7" x W7" x H37")



**Requirements:** Magliner Mini, Magliner Junior (Modified) or Magliner Senior (Modified)  
**Conflicts:** Mag Bag, Mag Ditty Bag, Mag C-Stand Holder (4), Mag Hi/Lo Hat Holder, Mag Front Box  
**Suggestions:** Mag Steadi-Cam "Swing" Handles, Mag Steadi-Cam Vest Holder, Mag Steadi-Cam Stand with 8" Wheel Kit

## Mag Steadi-Cam Vest Holder



The Mag Vest Holder has been modified to accept vests by all manufacturers. Vest Holder can be rotated 180 degrees out of the way when not in use and can be stored underneath Nose when Magliner needs to be folded.

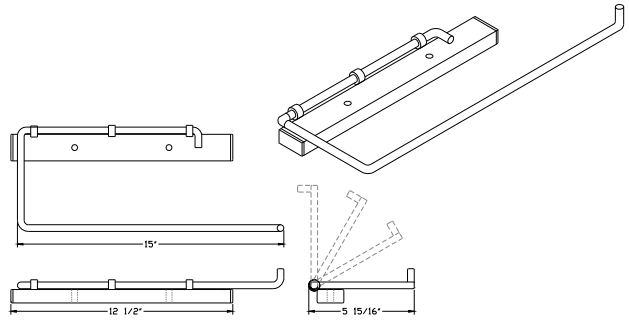

**Part No:** MAG-SV  
**Sale price:** \$ 165.00  
**Material:** Steel  
**Color:** Black  
**Max. Capacity:** 75 lbs.  
**Weight:** 2 lbs.  
**Dimensions:** D6" x W15 1/4" x H1 1/4"

**Shipping Weight/Dims:** 3 lbs. (L20" x W10" x H3")

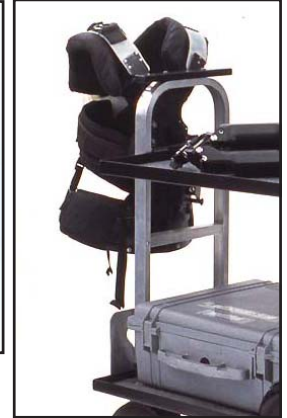

**Requirements:** Mag 30 or 40" Nose (Heavy Duty)

**Conflicts:** Mag Tripod Holder with 5/8" Baby Pin, Mag Nose 5/8" Baby Pin (Ctr.), Mag Nose 5/8" Baby Pin (Offset), Mag LCD HD Monitor Arm Nose Adapter

**Suggestions:** Mag Steadi-Cam Riser Unit, Mag Steadi-Cam "Swing" Handles

## Mag Steadi-Cam "Swing" Handles



The Mag Steadi-Cam "Swing" Handle was created to allow the operator to dock the Steadi-Cam gear on the Magliner without having to remove the monitor or the batteries from the unit. The handles can be installed with the prongs on the inside or the outside of the Magliner U-Handle. Both handles can be moved and lock anywhere within a 180 degree angle.

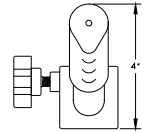
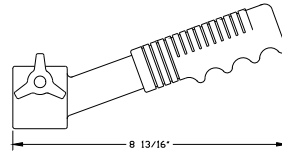
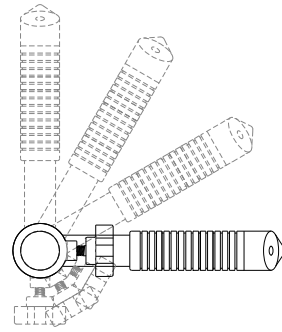

**Part No:** MAG-HS  
**Sale price:** \$ 280.00 (Set)  
**Material:** Steel  
**Color:** Black with Red Grip Handles  
**Max. Capacity:** 50 lbs.  
**Weight:** 4 lbs.  
**Dimensions:** L8 13/16" x W3 1/2" x H4" (ea.)

**Shipping Weight/Dims:** 5 lbs. (L11" x W7" x H5")



**Requirements:** Magliner Mini, Magliner Junior (Modified) or Magliner Senior (Modified)  
**Conflicts:** Mag Ditty Bag  
**Suggestions:** Mag Steadi-Cam Riser Unit, Mag Steadi-Cam Vest Holder

# Mag Steadi-Cam Stand 8" Wheel Kit (Stand not included)

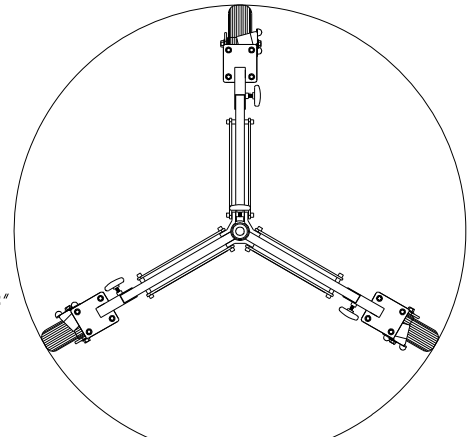
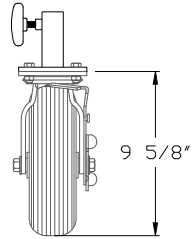
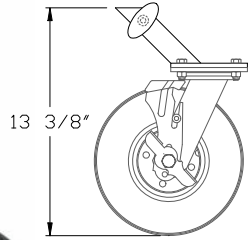
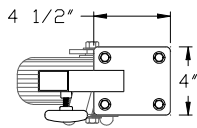

53 7/8" Diameter Circle

American Stand LS-30 with (1) Riser and 12" straps  
 Part No: MAG-SS LS-30  
 Sale price: \$ 375.00  
 Dims: Height 29" - 4.7" 15 1/2 lbs.  
 Note: American Stand must be outfitted with 12" straps

Part No: MAG-SS W-08 12

Sale price: \$ 350.00

Material: Steel

Color: Black

Max. Capacity: 300 lbs.

Weight: 28 lbs.

Dimensions: 53 7/8" Diam. x H43" (H64" with extended riser)

Shipping Weight/Dims: 30 lbs. (L18" x W13" x H13")



Requirements: American Stand Model LS-30

Conflicts: None

Suggestions: Mag Steadi-Cam Stand Front Box, Mag Steadi-Cam Stand Front Box Holder, Mag Steadi-Cam Stand Utility Tray, Mag Steadi-Cam Stand Holder



Equipped with 8" pneumatic wheels (Set of 3)

# Mag Steadi-Cam Stand 5" Wheel Kit (Stand not included)

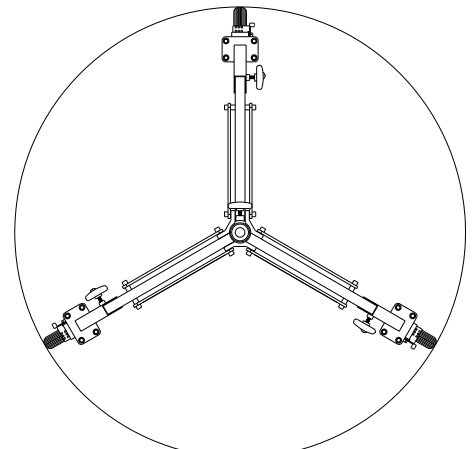
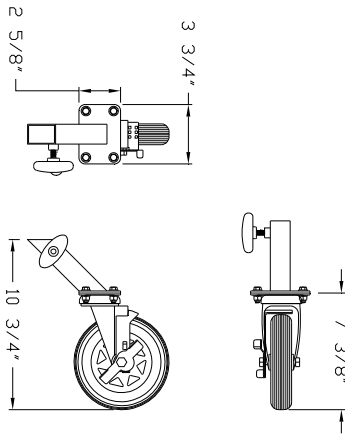

47" Diameter Circle

**American Stand LS-30 with (1) Riser and 12" straps**  
**Part No:** MAG-SS LS-30  
**Sale price:** \$ 375.00  
**Dims:** Height 29" - 4'7" 15 1/2 lbs.  
**Note:** American Stand must be outfitted with 12" straps

**Part No:** MAG-SS W-05 12  
**Sale price:** \$ 275.00  
**Material:** Steel  
**Color:** Black  
**Max. Capacity:** 300 lbs.  
**Weight:** 10 lbs.  
**Dimensions:** 47" Diam. x H39 1/2" (H60 1/2" with extended riser)

**Shipping Weight/Dims:** 11 lbs. (L15" x W9" x H7")



Equipped with 5" Thermal Wheels (Set of 3)

**Requirements:** American Stand Model LS-30  
**Conflicts:** None  
**Suggestions:** Mag Steadi-Cam Stand Front Box, Mag Steadi-Cam Stand Front Box Holder, Mag Steadi-Cam Stand Utility Tray, Mag Steadi-Cam Stand Holder



## Mag Steadi-Cam Stand Front Box Holder

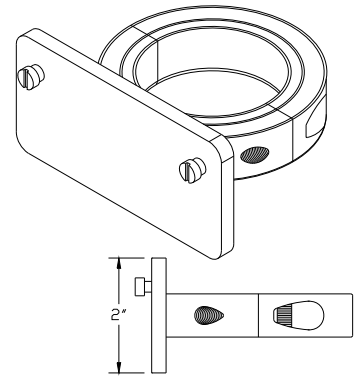
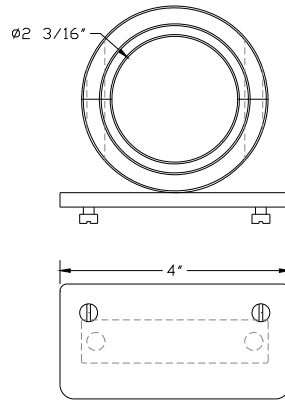

**Part No:** MAG-SS FB-A

**Sale price:** \$ 105.00

**Material:** Steel

**Color:** Black

**Max. Capacity:** 50 lbs.

**Weight:** 2 lbs.

**Dimensions:** L4" x W4" x H2"

**Shipping Weight/Dims:** 2 lbs. (L8" x W5" x H5")



**Requirements:** American Stand Model LS-30 with 12 inch straps (See page 64 for stand information)

**Conflicts:** None

**Suggestions:** Mag Steadi-Cam Stand Front Box, Mag Steadi-Cam Stand 8" Wheel Kit, Mag Steadi-Cam Stand 5" Wheel Kit, Mag Steadi-Cam Stand Utility Tray, Mag Steadi-Cam Stand Holder

# Mag Steadi-Cam Stand Holder

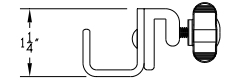
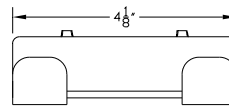
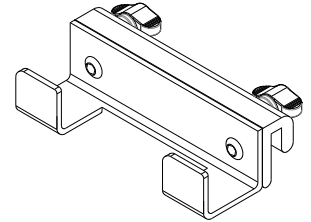
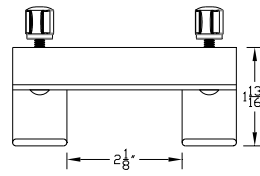

**Part No:** MAG-SS ES  
**Sale price:** \$ 75.00  
**Material:** Aluminum  
**Color:** Black  
**Max. Capacity:** 50 lbs.  
**Weight:** 1 lb.  
**Dimensions:** D1 5/8" x W4 1/8" x H1 1/4"

Shipping Weight/Dims: 1 lb. (L9" x W5" x H3")



**Requirements:** Magliner Shelf

**Conflicts:** None

**Suggestions:** Mag Steadi-Cam 8" Wheel Kit, Mag Steadi-Cam Stand 5" Wheel Kit, Mag Steadi-Cam Stand Front Box, Mag Steadi-Cam Stand Front Box Holder, Mag Steadi-Cam Utility Tray

## Mag Steadi-Cam Stand Utility Tray

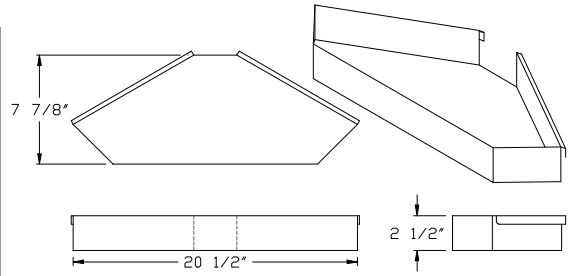

Mag Steadi-Cam Utility Tray has a lip in the rear to mount to American Stand® strap bars

**Part No:** MAG-SS UT

**Sale price:** \$ 195.00

**Material:** Steel

**Color:** Black

**Max. Capacity:** 50 lbs.

**Weight:** 4 lbs.

**Dimensions:** D7 7/8" x W20 1/2" x H2 1/2"

**Shipping Weight/Dims:** 5 lbs. (L23" x W11" x H5")



**Note:** American Stand must be outfitted with 12" straps

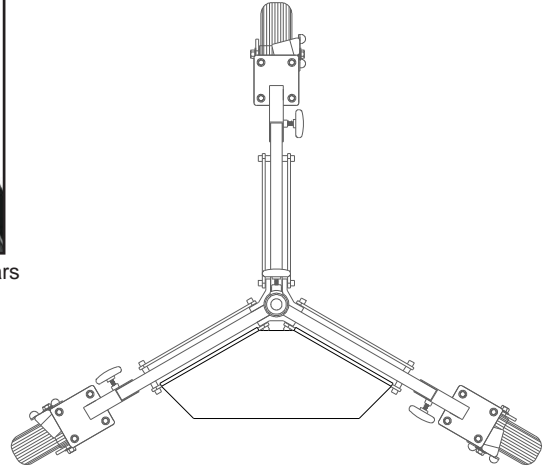

**Requirements:** American Stand® Model LS-30

**Conflicts:** None

**Suggestions:** Mag Steadi-Cam 8" Wheel Kit, Mag Steadi-Cam Stand 5" Wheel Kit, Mag Steadi-Cam Stand Front Box, Mag Steadi-Cam Stand Front Box Holder, Mag Steadi-Cam Stand Holder

# Mag Steadi-Cam Stand Utility Tray Plus

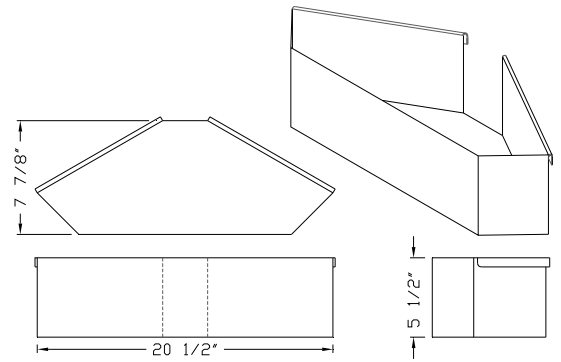

Mag Steadi-Cam Utility Tray has a lip in the rear to mount to American Stand® strap bars

**Part No:** MAG-SS UT PLUS  
**Sale price:** \$215.00  
**Material:** Steel  
**Color:** Black  
**Max. Capacity:** 50 lbs.  
**Weight:** 4 lbs.  
**Dimensions:** D7 7/8" x W20 1/2" x H5 1/2"

**Shipping Weight/Dims:** 7 lbs. (L23" x W11" x H7")



**Note:** American Stand must be outfitted with 12" straps

**Requirements:** American Stand® Model LS-30

**Conflicts:** None

**Suggestions:** Mag Steadi-Cam 8" Wheel Kit, Mag Steadi-Cam Stand 5" Wheel Kit, Mag Front Box, Mag Steadi-Cam Stand Front Box Holder, Mag Steadi-Cam Stand Holder

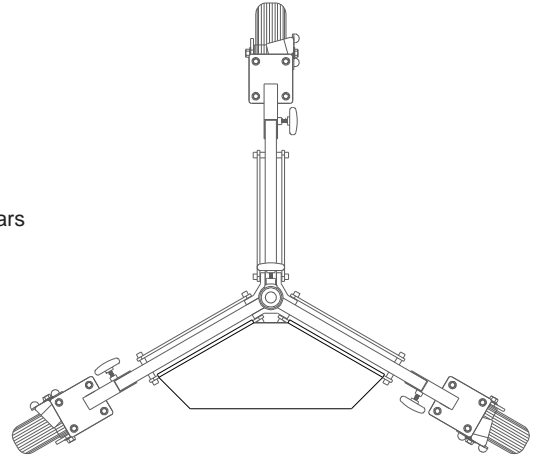

## Mag Grip/Light Caddy (Large)



**Part No:** MAG-I 24  
**Sale price:** \$ 425.00  
**Material:** Steel  
**Color:** Black  
**Max. Capacity:** 100 lbs.  
**Weight:** 26 lbs.  
**Dimensions:** D11" x W27" x H33"

The Mag Grip/Light Caddy comes in two sizes. The difference between the two is the width. The small Caddy was designed to carry 18 x 24 flags, while the large Caddy will carry 24 x 36 flags as well.

Both units can also carry small electrical stands and/or tripods. An adjustable separator keeps the stands away from the flags. There are two rubber bungees built into the Caddy to be used when tightening objects down.

If additional stands are required, you can use removable stand holders which attach to the outside of the Caddy.

Stand holders are available in quad, double and single format.

Caddy attaches to the middle horizontal bar of the nose and is easily removed. When standing by itself it uses four rubber feet to stand on.

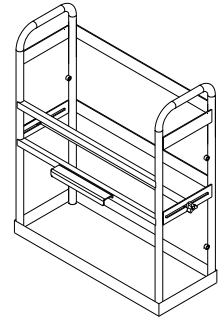
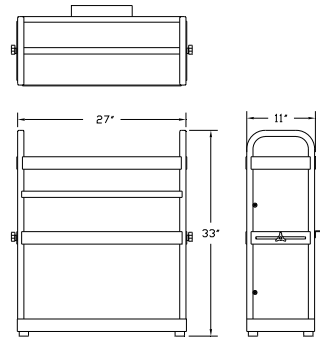

**Shipping Weight/Dims:** 30 lbs. (L13" x W29" x H34")



Mag Grip/Light Caddy loaded with stands and flags

**Requirements:** Mag 30" Nose (Heavy Duty) and Mag Top Shelf (Magliner Junior or Senior, 18" or 24")

**Conflicts:** Mag 18" or 24" Middle Shelf, Mag Tripod Holder with 5/8" Baby Pin, Mag Steadi-Cam Vest Holder

**Suggestions:** Mag Light Stand Holder (Single, Double, Quad), Mag Rear Quad Axle Kit, Mag Front Dual 8" Wheels, Mag C-Stand Holder (4)

## Mag Grip/Light Caddy (Small)

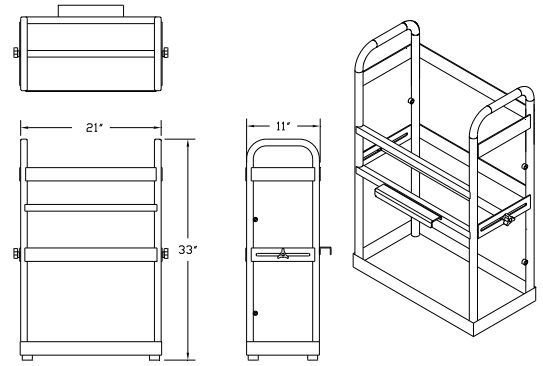

**Part No:** MAG-I 18  
**Sale price:** \$ 400.00  
**Material:** Steel  
**Color:** Black  
**Max. Capacity:** 100 lbs.  
**Weight:** 29 lbs.  
**Dimensions:** D11" x W21" x H33"

**Shipping Weight/Dims:** 29 lbs. (L14" x W24" x H35")



**Requirements:** Mag 30" Nose (Heavy Duty) and Mag Top Shelf (Magliner Junior or Senior, 18" or 24")  
**Conflicts:** Mag 18" or 24" Middle Shelf, Mag Tripod Holder with 5/8" Baby Pin, Mag Steadi-Cam Vest Holder  
**Suggestions:** Mag Light Stand Holder (Single, Double, Quad), Mag Rear Quad Axle Kit, Mag Front Dual 8" Wheels

## Mag Light Stand Holders

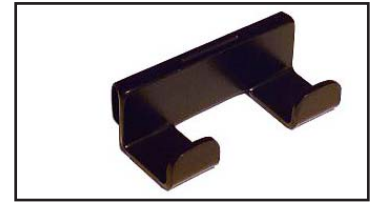
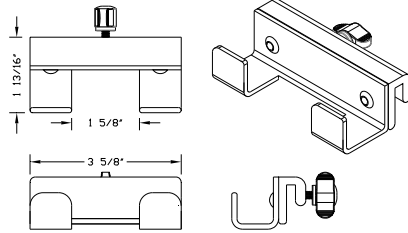

**Part No:** MAG-ES1 (Single)  
**Sale price:** \$ 75.00  
**Material:** Aliminum  
**Color:** Black  
**Max. Capacity:** 50 lbs.  
**Weight:** 1 lb.  
**Dimensions:** D1 5/8" x W3 5/8" x H1 1/4"

**Shipping Weight/Dims:** 1 lb. (L9" x W5" x H3")



**Part No:** MAG-ES2 (Dual)  
**Sale price:** \$ 85.00  
**Material:** Aluminum  
**Color:** Black  
**Max. Capacity:** 75 lbs.  
**Weight:** 1 lbs.  
**Dimensions:** D1 5/8" x W8 1/4" x H1 1/4"

**Shipping Weight/Dims:** 1 lb. (L9" x W5" x H3")

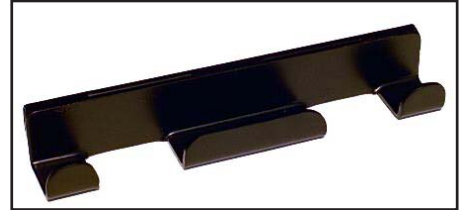

**Part No:** MAG-ES4 (Quad)  
**Sale price:** \$ 115.00  
**Material:** Aluminum  
**Color:** Black  
**Max. Capacity:** 100 lbs.  
**Weight:** 2 lbs.  
**Dimensions:** D1 5/8" x W17 1/2" x H1 1/4"

**Shipping Weight/Dims:** 2 lb. (L19" x W5" x H5")

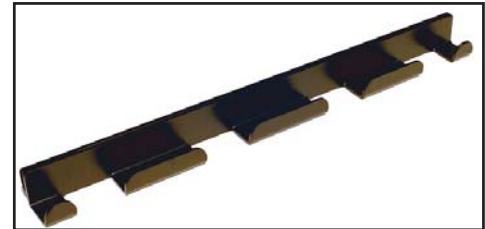

**Requirements:** Mag Grip/Light Caddy or Mag Top Shelf (Magliner Junior or Senior, 18" or 24")  
**Conflicts:** None  
**Suggestions:** Mag C-Stand Holder (4), Mag C-Stand Holder (1)

## Utility Boxes

**Part No:** MAG-UB10  
**Sale price:** \$135.00  
**Material:** Aluminum  
**Color:** Black  
**Max. Capacity:** 20 lbs.  
**Weight:** 2 lbs.  
**Dimensions:** L11 1/2" x W4" x H5"  
 (ID L10" x W3 3/4" x H5")

**Shipping Weight/Dims:** 3 lbs. (L7" x W7" x H13")

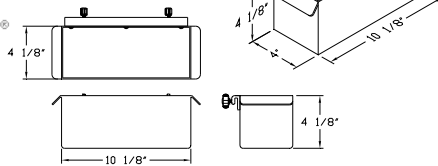

**Part No:** MAG-UB35  
**Sale price:** \$165.00  
**Material:** Aluminum  
**Color:** Black  
**Max. Capacity:** 30 lbs.  
**Weight:** 6 lbs.  
**Dimensions:** L36 1/2" x W4" x H5"  
 (ID L35" x W3 3/4" x H5")

**Shipping Weight/Dims:** 7 lbs. (L6" x W6" x H38")

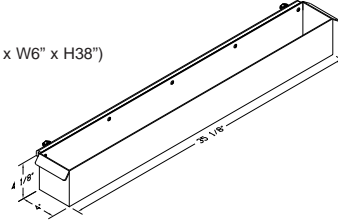

**Requirements:** Mag Junior or Senior Top Shelf (18" or 24")  
**Conflicts:** Mag 2-Space Roller Sliding Drawer with Lock, Mag Keyboard Tray  
**Suggestions:** Mag Grip/Light Caddy, Mag C-Stand Holder (4), Mag C-Stand Holder (1)

**Part No:** MAG-UB46  
**Sale price:** \$175.00  
**Material:** Aluminum  
**Color:** Black  
**Max. Capacity:** 40 lbs.  
**Weight:** 8 lbs.  
**Dimensions:** L48" x W4" x H5"  
 (ID L46" x W3 3/4" x H5")

**Shipping Weight/Dims:** 9 lbs. (L6" x W6" x H51")

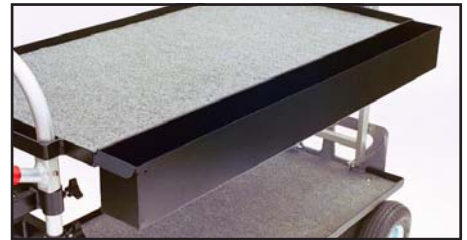
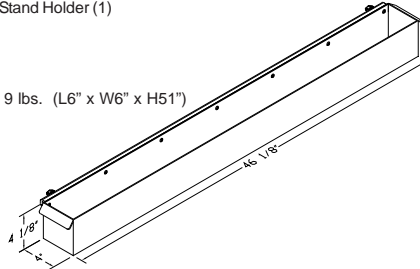

**Requirements:** Mag Senior Top Shelf (18" or 24")  
**Conflicts:** Mag Junior Top Shelf (18" or 24"), Mag 2-Space Roller Sliding Drawer with Lock, Mag Keyboard Tray  
**Suggestions:** Mag Grip/Light Caddy, Mag C-Stand Holder (4), Mag C-Stand Holder (1)



# Mag Umbrella Holder

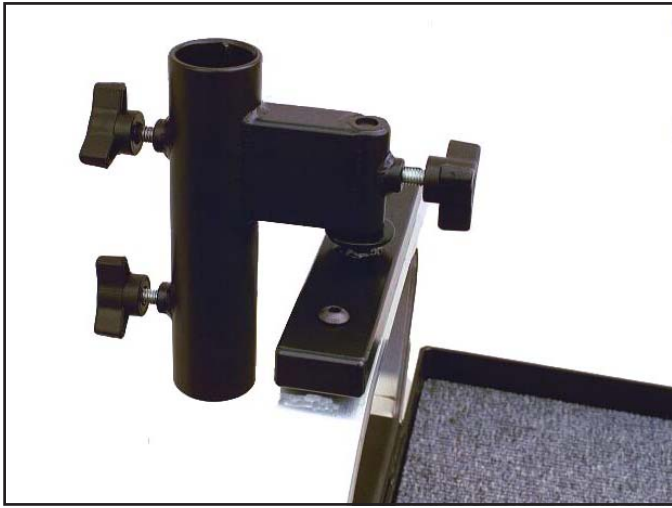

The Mag Umbrella Holder attached to Mag Nose Pin (Ctr.)

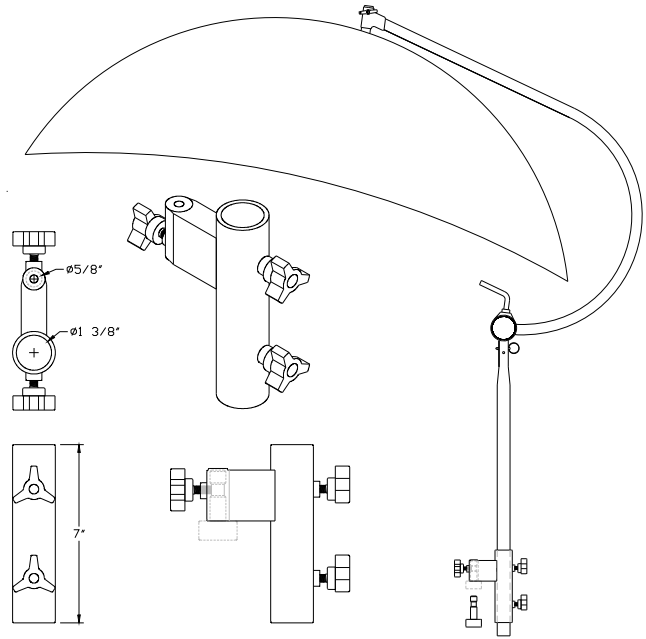

**Part No:** MAG-UH  
**Sale price:** \$ 150.00  
**Material:** Steel  
**Color:** Black  
**Max. Capacity:** 50 lbs.  
**Weight:** 2 lbs.  
**Dimensions:** L7" x W1 11/16" x H7"

**Shipping Weight/Dims:** 3 lbs. (L9" x W8" x H4")



**Requirements:** Mag Tripod Holder with 5/8" Baby Pin or Mag Nose 5/8" Baby Pin (Ctr.) or Mag Nose 5/8" Baby Pin (Offset) or Mag U-Handle 5/8" Baby Pin  
**Conflicts:** Mag Steadi-Cam Vest Holder, Mag Tripod Holder  
**Suggestions:** Mag Umbrella, Mag Tripod Holder with 5/8" Baby Pin

# Mag Umbrella

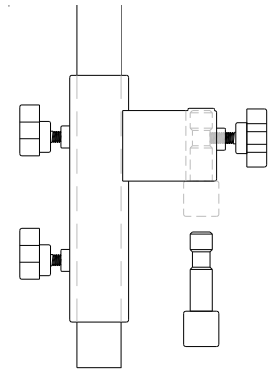
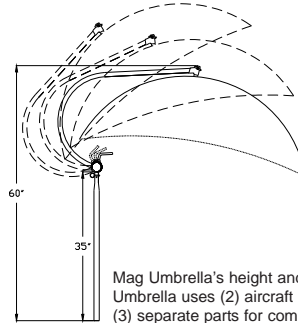
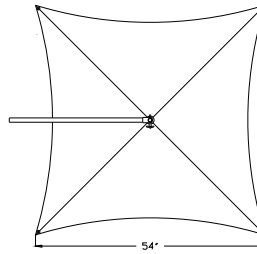

Close-up of Umbrella with Umbrella Holder attached to 5/8" Baby Pin accessory

Mag Umbrella's height and tilt angle is fully adjustable. Umbrella uses (2) aircraft style pins to break down into (3) separate parts for compact transportation.

**Part No:** MAG-U  
**Sale price:** \$ 235.00 (Hardware only, canvas additional)  
**Material:** Steel  
**Color:** Clear Zinc Plate  
**Max. Capacity:** N/A  
**Weight:** 12 lbs.  
**Dimensions:** L54" x W54" x H60"  
**Specify canvas color:** Red, White, Black

**Shipping Weight/Dims:** MAG-U 7 lbs. (L41" x W19" x H3") & 7 lbs. (L5" x W5" x H44")



**Note:** Select type of canvas from list below  
**Mag Umbrella Canvas (Black) (MAG-U A-BK) \$ 95.00**  
**Mag Umbrella Canvas (Red) (MAG-U A-R) \$ 110.00**  
**Mag Umbrella Canvas (White) (MAG-U A-W) \$ 110.00**

**Mag Umbrella Holder (MAG-UH) \$ 150.00**  
**Mag Nose 5/8" Baby Pin (Center) (MAG-NP-CTR) \$ 81.00**

**Requirements:** Mag Umbrella Holder and Mag Nose 5/8" Baby Pin (Center) or Mag Nose 5/8" Baby Pin (Offset) or Mag U-Handle 5/8" Baby Pin or Tripod Holder with 5/8" Baby Pin  
**Conflicts:** None  
**Suggestions:** Mag Sand/Dune Wheel Kit

# Mag DIT HD Tent



The MAG HD Tent has been a project in progress for the last two years. Backstage was asked to build a tent that would accomplish the following:

1. Adapt to a cart so it could be moved at the same time
2. Tent must be white on the outside to deflect heat and pitch black inside to see monitors in the middle of the day
3. Tent must be easy to assemble
4. Tent must be light weight and durable

- Water resistant
- Front door uses zipper for quick access
- Built -in velcro loops to hold door open
- Rear window with mesh and cover
- Built-in grommets to secure to sandbags
- Carabiners to hold down sandbags (4)
- Skirt is one piece, attaches to top with velcro
- Tent may be offset 30° for extra room
- Includes all necessary hardware
- Custom Bag to hold tent and hardware
- Attaches to cart by hooking up tent support shaft to an Umbrella Holder and a 5/8" Baby Pin (not included)

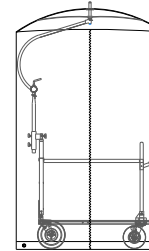
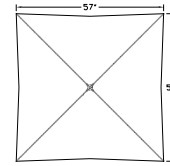

HD TENT (Front)

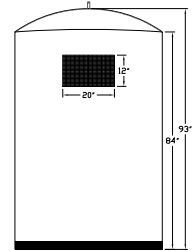

HD TENT (Rear)

**Mag Umbrella Holder (MAG-UH) \$ 150.00**  
**Mag Nose 5/8" Baby Pin (Center) (MAG-NP-CTR) \$ 81.00**

**Part No:** MAG-U HD  
**Sale price:** \$ 1,275.00  
**Material:** Ultra Bounce (Tent) / Steel (Hardware)  
**Color:** White/Black  
**Max. Capacity:** N/A  
**Weight:** 19 lbs.  
**Dimensions:** L57" x W57" x H93"

**Shipping Weight/Dims:** MAG-U HD 11 lbs. (L41" x W19" x H3") & 10 lbs. (L5" x W5" x H44")



**Requirements:** Magliner Mini, Magliner Junior (Modified) or Magliner Senior (Modified), Mag Umbrella Holder, Mag Nose 5/8" Baby Pin (Center)  
**Conflicts:** Mag Antenna Riser  
**Suggestions:** Mag LCD HD Monitor Arm, Mag LCD Tilt Head with Tilt Head Pin adapter (4, 8 or 12'), Mag LCD HD Monitor Arm U-Handle Adapter



# Mag Rain Tent



The Mag Rain Tent looks similar to the Mag HD Tent, but we have made some major modifications in order for this product to accomplish what is supposed to do. The main features include water proof top and sides, three large clear windows with covers to block light and double velcro to join top and sides securely. This tent may be used as an HD tent as well.

- Attaches to cart by hooking up tent support shaft to an Umbrella Holder and a 5/8" Baby Pin (not included)
- Moves along with cart
- Easy to assemble
- Light weight and durable
- Water proof
- Front door uses zipper for quick access
- Built -in velcro loops to hold door open
- Three windows with clear plastic and cover
- Built-in grommets to secure to sandbags
- Carabiners to hold down sandbags (4)
- Skirt is one piece, attaches to top with velcro
- Tent may be offset 30° for extra room
- Includes all necessary hardware
- Custom Bag to hold tent and hardware

**Mag Umbrella Holder (MAG-UH) \$ 150.00**  
**Mag Nose 5/8" Baby Pin (Center) (MAG-NP-CTR) \$ 81.00**

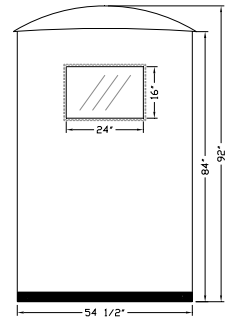
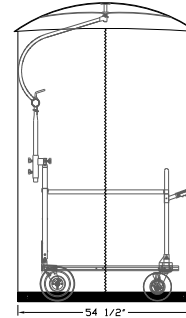
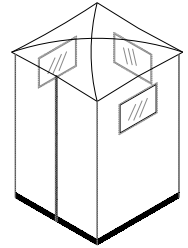
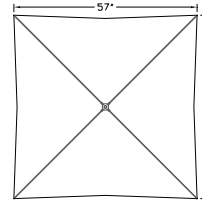

RAIN TENT (Front)

RAIN TENT (Rear)

**Part No:** MAG-U RT  
**Sale price:** \$ 1,375.00  
**Material:** Ultra Bounce (Tent) / Steel (Hardware)  
**Color:** White/Black  
**Max. Capacity:** N/A  
**Weight:** 24 lbs.  
**Dimensions:** L57" x W57" x H93"

**Shipping Weight/Dims:** MAG-U HD 15 lbs. (L41" x W19" x H3") & 10 lbs. (L5" x W5" x H44")



**Requirements:** Magliner Mini, Magliner Junior (Modified) or Magliner Senior (Modified), Mag Umbrella Holder, Mag Nose 5/8" Baby Pin (Center)  
**Conflicts:** Mag Antenna Riser  
**Suggestions:** Mag LCD HD Monitor Arm, Mag LCD Tilt Head with Tilt Head Pin adapter (4, 8 or 12'), Mag LCD HD Monitor Arm U-Handle Adapter

## Mag C-Stand Holder (4)

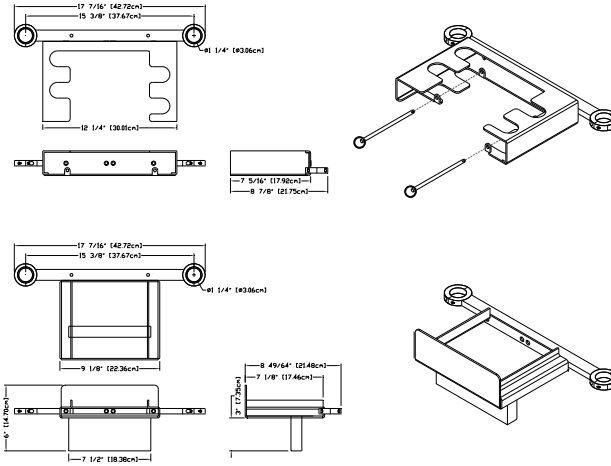

Mag C-Stand Holder (4) with locking system to keep C-Stands in place. Will hold up to 4 C-Stands in place. Will hold up to 20" shorties to full 40" size.

**Part No:** MAG-CS4

**Sale price:** \$ 425.00

**Material:** Aluminum

**Color:** Black

**Max. Capacity:** 125 lbs.

**Weight:** 6 lbs.

**Dimensions:** Top D9" x W17 7/16" x H2 1/4", Bottom D9" x W17 7/16" x H6"

**Shipping Weight/Dims:** 7 lbs. (L19" x W11" x H7")

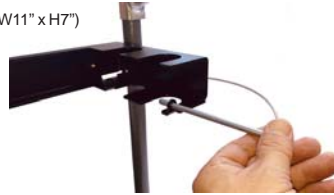

**Requirements:** Magliner Mini, Magliner Junior (Modified) or Magliner Senior (Modified)

**Conflicts:** Mag Bag, Mag Ditty Bag, Mag Hi/Lo Hat Holder, Mag Steadi-Cam Bumper, Mag Front Box

**Suggestions:** Mag Grip/Light Caddy

## Mag C-Stand Holder Set (Single)



**Part No:** MAG-CS1X  
**Sale price:** \$ 115.00  
**Material:** Aluminum  
**Color:** Black  
**Max. Capacity:** 70 lbs.  
**Weight:** 2 lbs.  
**Dimensions:** D2 1/2" x W5 1/8" x H4 7/16"

**Shipping Weight/Dims:** 2 lbs. (L9" x W8" x H4")



**Requirements:** Mag Top Shelf (Mag Senior, 18" or 24")  
**Conflicts:** Mag 2, 3 or 4-Space Roller Sliding Drawer with Lock  
**Suggestions:** Mag Grip/Light Caddy



## Mag Nose 5/8" Baby Pin (Center)



The Mag Nose 5/8" Baby Pin (Center) designed to handle more than one accessory at a time. All aluminum construction in anodized black.

**Note:** All Nose Pins are modular, you may set up accessory with one, two or three 5/8" Baby Pins depending on your needs. Additional 5/8" Baby Pin (MAG-NP PIN) can be purchased separately for \$ 13.00 dollars.

**Part No:** MAG-NP CTR  
**Sale price:** \$ 81.00  
**Material:** Aluminum/Steel  
**Color:** Black  
**Max. Capacity:** 50 lbs.  
**Weight:** 14 oz.  
**Dimensions:** D1 1/2" x W7" x H2 7/8"

**Shipping Weight/Dims:** 2 lbs. (L9" x W5" x H3")

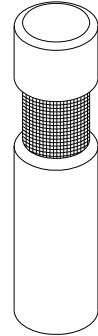
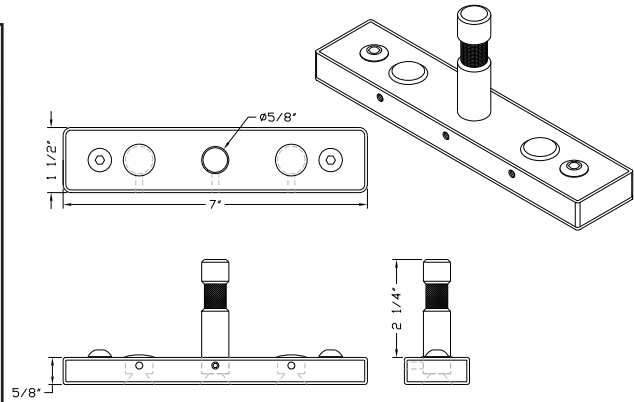

MAG-NP PIN

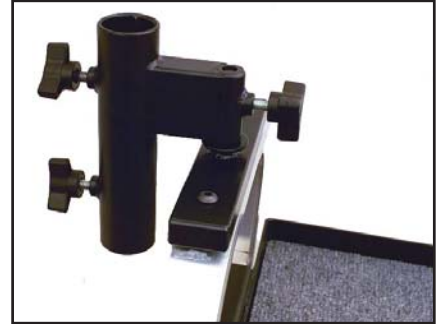

Mag Umbrella Holder attached to Mag Nose 5/8" Baby Pin

**Requirements:** Mag 30" Nose (Heavy Duty)

**Conflicts:** Mag Sound Tray, Mag Tripod Holder with 5/8" Baby Pin, Mag Steadi-Cam Vest Holder, Mag LCD HD Monitor Arm Nose Adapter

**Suggestions:** Mag Umbrella Holder, Mag Dual Video Monitor Bracket, Mag Offset Arm, Mag Swing Arm, Mag Monitor Horizontal Bar

## Mag Nose 5/8" Baby Pin (Offset)



The Mag Nose 5/8" Baby Pin (Offset) was designed to work with the Mag Sound Tray. All aluminum construction in anodized black.

**Note:** All Nose Pins are modular, you may set up accessory with one, two or three 5/8" Baby Pins depending on your needs. Additional 5/8" Baby Pin (MAG-NP PIN) can be purchased separately for \$ 13.00 dollars.

**Part No:** MAG-NP OS  
**Sale price:** \$81.00  
**Material:** Aluminum/Steel  
**Color:** Black  
**Max. Capacity:** 50 lbs.  
**Weight:** 14 oz.  
**Dimensions:** D1 1/2" x W7" x H2 7/8"

**Shipping Weight/Dims:** 2 lbs. (L9" x W5" x H3")

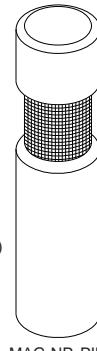
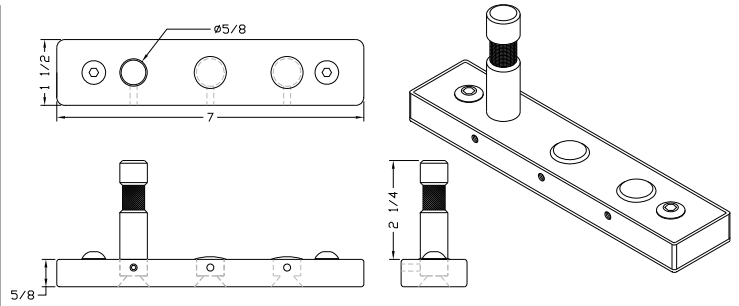

MAG-NP PIN



Mag Nose 5/8" Baby Pin (Offset) being used with Mag Sound Tray

**Requirements:** Mag 30" Nose (Heavy Duty)

**Conflicts:** Mag Tripod Holder with 5/8" Baby Pin, Mag Steadi-Cam Vest Holder, Mag LCD HD Monitor Arm Nose Adapter

**Suggestions:** Mag Umbrella Holder, Mag Dual Video Monitor Bracket, Mag Lap Top Tray, Mag Offset Arm, Mag Swing Arm, Mag 5/8" Baby Spud Extension (4", 6", 8")



## Mag Nose 5/8" Baby Pin (Dual)

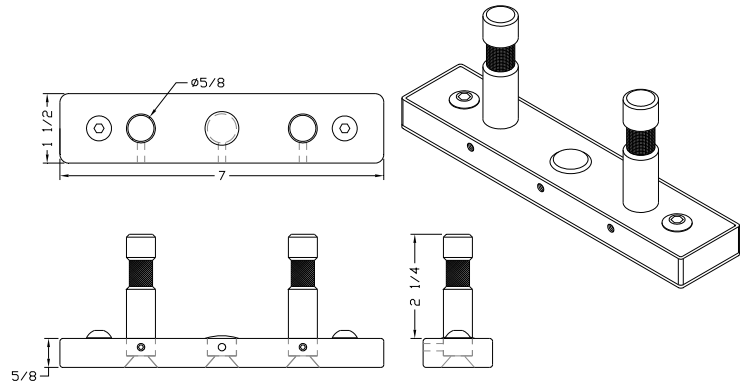
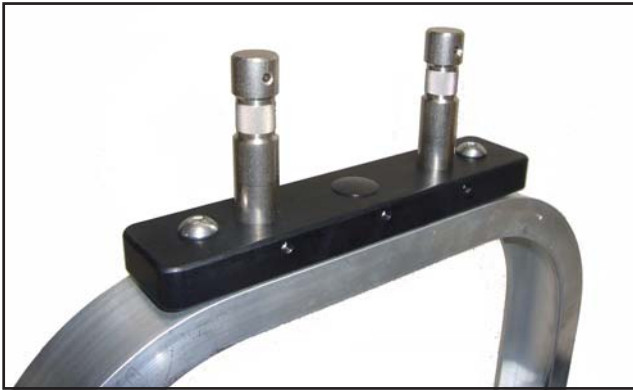

The Mag Nose 5/8" Baby Pin (Dual) same as MAG-NP OS and MAG-NP CTR but designed to handle more than one accessory at a time. All aluminum construction in anodized black.

**Note:** All Nose Pins are modular, you may set up accessory with one, two or three 5/8" Baby Pins depending on your needs. Additional 5/8" Baby Pin (MAG-NP PIN) can be purchased separately for \$13.00 dollars.

**Part No:** MAG-NP DUAL  
**Sale price:** \$94.00  
**Material:** Aluminum/Steel  
**Color:** Black  
**Max. Capacity:** 50 lbs.  
**Weight:** 1.2 lb.  
**Dimensions:** D1 1/2" x W7" x H2 7/8"

**Shipping Weight/Dims:** 2 lbs. (L9" x W5" x H3")

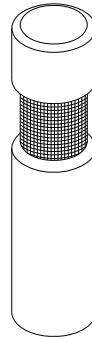

MAG-NP PIN



Mag Nose 5/8" Baby Pin (Dual) shown with Mag Umbrella Holder and Mag Lap Top Offset Arm.

**Requirements:** Mag 30" Nose (Heavy Duty)

**Conflicts:** Mag Sound Tray, Mag Tripod Holder with 5/8" Baby Pin, Mag Steadi-Cam Vest Holder, Mag LCD HD Monitor Arm Nose Adapter

**Suggestions:** Mag Umbrella Holder, Mag Dual Video Monitor Bracket, Mag Lap Top Tray, Mag Offset Arm, Mag Swing Arm, Mag Monitor Horizontal Bar

# Mag Nose 5/8" Baby Pin (Triple)



The Mag Nose 5/8" Baby Pin (Triple) designed to handle up to three accessories at one time. All aluminum construction anodized in black.

**Note:** All Nose Pins are modular, you may set up accessory with one, two or three 5/8" Baby Pins depending on your needs. Additional 5/8" Baby Pin (MAG-NP PIN) can be purchased separately for \$ 13.00 dollars.

**Part No:** MAG-NP TRIPLE  
**Sale price:** \$ 107.00  
**Material:** Aluminum  
**Color:** Black  
**Max. Capacity:** 50 lbs.  
**Weight:** 1.4 lbs.  
**Dimensions:** D1 1/2" x W7" x H2 7/8"

**Shipping Weight/Dims:** 2 lbs. (L9" x W5" x H3")

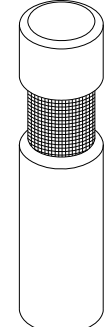
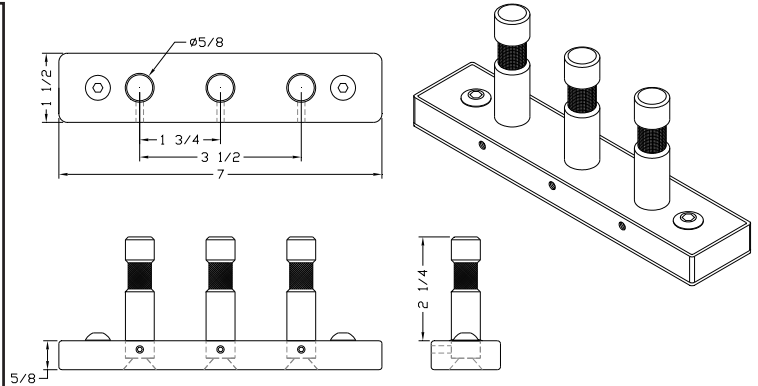

MAG-NP PIN

**Requirements:** Mag 30" Nose (Heavy Duty)  
**Conflicts:** Mag Sound Tray, Mag Tripod Holder with 5/8" Baby Pin, Mag Steadi-Cam Vest Holder, Mag LCD HD Monitor Arm Nose Adapter  
**Suggestions:** Mag Umbrella Holder, Mag Dual Video Monitor Bracket, Mag Lap Top Tray, Mag Offset Arm, Mag Swing Arm, Mag Monitor Horizontal Bar

## Mag Nose "Snap-On" 5/8" Baby Pin (Side)

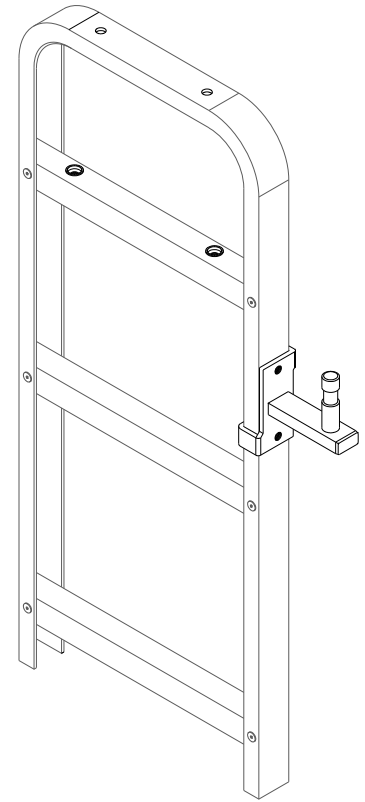
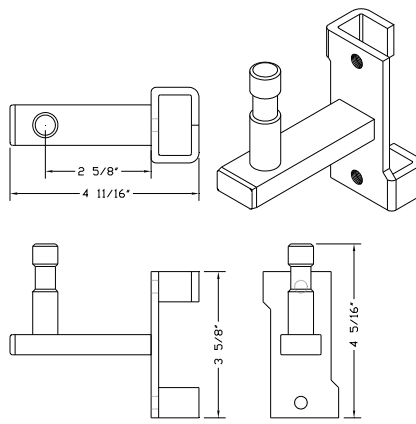

The Mag Nose "Snap-On" 5/8" Baby Pin (Side) was designed to handle those accessories that need to be at a lower level, such as the Mag Lap Top Tray. Unit can be positioned anywhere along either side of the Mag Nose.

**Part No:** MAG-NP SD

**Sale price:** \$81.00

**Material:** Steel

**Color:** Black

**Max. Capacity:** 50 lbs.

**Weight:** 1 lb.

**Dimensions:** L4 11/16" x W1-7/8" x H4 5/16"

**Shipping Weight/Dims:** 2 lbs. (L9" x W5" x H3")



**Requirements:** Mag Nose

**Conflicts:** Mag 30" Adjustable Folding Nose Cross Bar

**Suggestions:** Mag Lap Top Tray, Mag Swing Arm, Mag Offset Arm, Mag LCD HD Monitor Arm, Mag LCD HD Monitor Arm Nose Adapter, Mag LCD HD Monitor Arm U-Handle Adapter

## Mag U-Handle 5/8" Baby Pin



The Mag U-Handle 5/8 Baby Pin has been used to accommodate a number of Mag accessories. The pin is made of one inch solid steel bar machined to have a tight fit around the Magliner "U" Handle Bar. It is secured by a special notch support spacer which locks in place with a grade 8 bolt.



Mag U-Handle 5/8" Baby Pin shown with Mag Flat Screen Video Dual Baby Riser (Adj.)

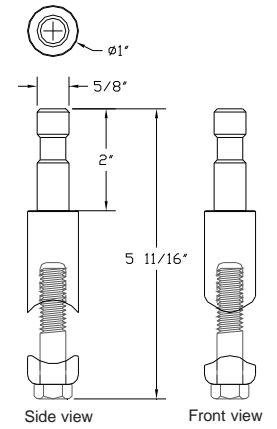

**Part No:** MAG-S  
**Sale price:** \$ 89.00  
**Material:** Steel  
**Color:** Nickle Plate  
**Max. Capacity:** 100 lbs.  
**Weight:** 1 lb.  
**Dimensions:** 1" Diam. x 5 1/4"

**Shipping Weight/Dims:** 1 lb. (L9" x W5" x H3")



**Requirements:** Magliner Mini, Magliner Junior (Modified) or Magliner Senior (Modified)  
**Conflicts:** Mag Sound Tray  
**Suggestions:** Mag Umbrella Holder, Mag Lap Top Tray, Mag Video Dual Bracket, Mag Video Dual Bracket (Teleopic)

## Mag "U" Handle 5/8" Offset Baby Pin



The Mag U-Handle Offset Baby Pin (Offset) was designed to work together with the Mag Lap Top Tray and the Mag Lap Top Tray Swing Arm. It allows the user to adjust the height and position of the Lap Top Tray. Very useful when sitting down and moving about your cart.

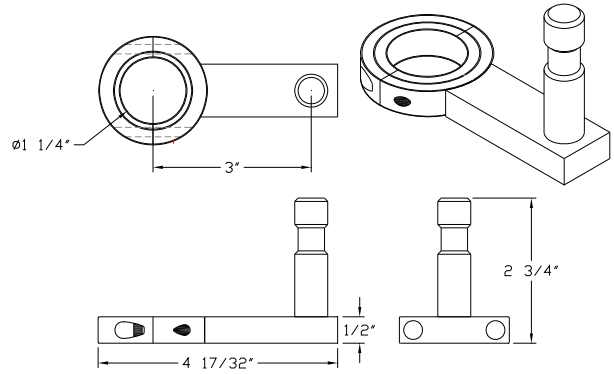

**Part No:** MAG-HUP  
**Sale price:** \$81.00  
**Material:** Steel  
**Color:** Black  
**Max. Capacity:** 50 lbs.  
**Weight:** 1 lb.  
**Dimensions:** D4 1/2" x W2" x H2 3/4"

**Shipping Weight/Dims:** 1 lb. (L9" x W5" x H3")



MAG-HUP being used with Mag Swing Arm and Mag Lap Top Tray

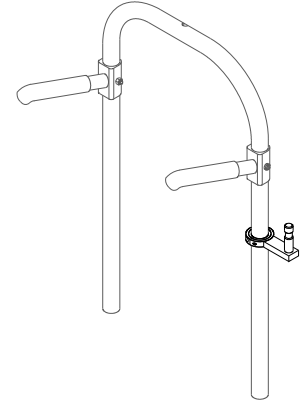

**Requirements:** Modified Magliner Mini, Junior or Senior

**Conflicts:**

**Suggestions:** Mag Lap Top Tray, Mag Swing Arm, Mag Swing Arm Deluxe, Mag 5/8" Nose Pin (Side), Mag LCD HD Monitor Arm, Mag LCD HD Monitor Arm U-Handle Adapter

## Mag 5/8" Baby Spud 4" Extension

**Part No:** MAG-RISER 4  
**Sale price:** \$32.00  
**Material:** Steel  
**Color:** Black  
**Max. Capacity:** 100 lbs.  
**Weight:** 1 lb.  
**Dimensions:** D3" x W1 1/8" x H5 5/8"

**Shipping Weight/Dims:** 1 lb. (L9" x W5" x H3")

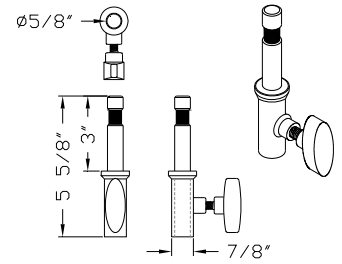

## Mag 5/8" Baby Spud 6" Extension

**Part No:** MAG-RISER 6  
**Sale price:** \$35.00  
**Material:** Steel  
**Color:** Black  
**Max. Capacity:** 100 lbs.  
**Weight:** 1 lb.  
**Dimensions:** D3" x W1 1/8" x H8"

**Shipping Weight/Dims:** 2 lbs. (L9" x W5" x H3")

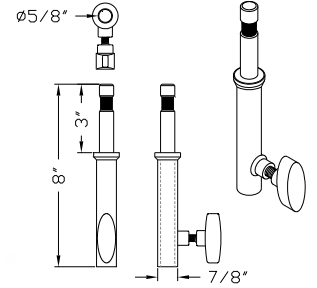

## Mag 5/8" Baby Spud 8" Extension

**Part No:** MAG-RISER 8  
**Sale price:** \$38.00  
**Material:** Steel  
**Color:** Black  
**Max. Capacity:** 100 lbs.  
**Weight:** 1 lb.  
**Dimensions:** D3" x W1 1/8" x H10 1/4"

**Shipping Weight/Dims:** 2 lbs. (L5" x W5" x H13")

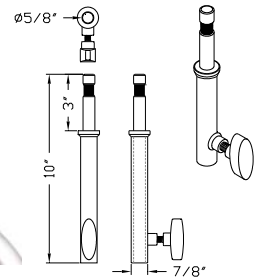

## Mag Baby Extension 6" to 8 1/2" (Telescopic)

**Part No:** MAG-RISER EXT-TEL SM  
**Sale price:** \$ 90.00  
**Material:** Steel  
**Color:** Black  
**Max. Capacity:** 100 lbs.  
**Weight:** 1 lb.  
**Dimensions:** D2 3/4" x W1 3/4" x H7 3/4"

Shipping Weight/Dims: 1 lb. (L9" x W5" x H3")

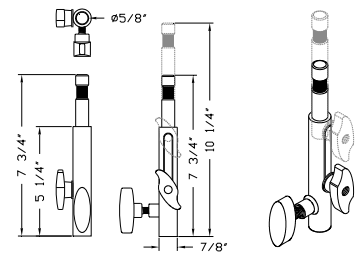

## Mag Baby Extension 8" to 12" (Telescopic)

**Part No:** MAG-RISER EXT-TEL MD  
**Sale price:** \$ 105.00  
**Material:** Steel  
**Color:** Black  
**Max. Capacity:** 100 lbs.  
**Weight:** 1 lb.  
**Dimensions:** D3" x W1 1/8" x H8"

Shipping Weight/Dims: 2 lbs. (L5" x W5" x H13")

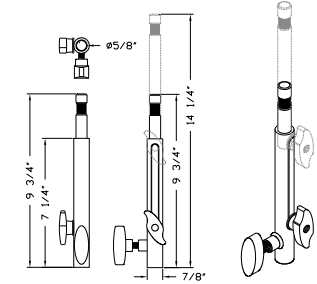

## Mag Baby Extension 12" to 20" (Telescopic)

**Part No:** MAG-RISER EXT-TEL LG  
**Sale price:** \$ 120.00  
**Material:** Steel  
**Color:** Black  
**Max. Capacity:** 100 lbs.  
**Weight:** 2 lbs.  
**Dimensions:** D3" x W1 1/8" x H10 1/4"

Shipping Weight/Dims: 2 lbs. (L5" x W5" x H19")

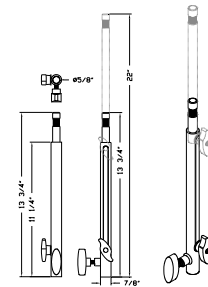

## Mag 5/8" Baby Receiver Pin to 1/4-20 Male Thread

Part No: MAG-PIN 5/8" TO 1/4"  
 Sale price: \$45.00  
 Material: Steel  
 Color: Black  
 Max. Capacity: 25 lbs.  
 Weight: 1 lb.  
 Dimensions: D2 3/4" x W13/16" x H2 3/8"

Shipping Weight/Dims: 1 lb. (L9" x W5" x H3")

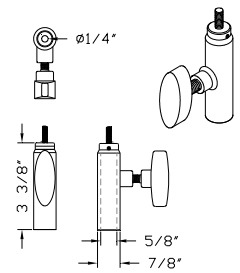

## Mag 5/8" Baby Receiver Pin to 3/8-16 Male Thread

Part No: MAG-PIN 5/8" TO 3/8"  
 Sale price: \$48.00  
 Material: Steel  
 Color: Black  
 Max. Capacity: 25 lbs.  
 Weight: 1 lb.  
 Dimensions: D2 3/4" x W13/16" x H3 3/8"

Shipping Weight/Dims: 1 lb. (L9" x W5" x H3")

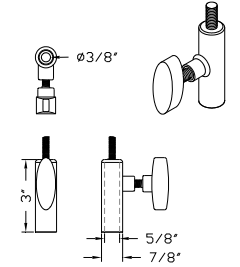

## Mag 5/8" Baby Pin Receiver to Junior Spud Adapter

Part No: MAG-PIN BABY TO JR  
 Sale price: \$70.00  
 Material: Steel  
 Color: Black  
 Max. Capacity: 100 lbs.  
 Weight: 1 lb.  
 Dimensions: Diam 1 3/8" x H4 1/2"

Shipping Weight/Dims: 2 lbs. (L9" x W5" x H3")

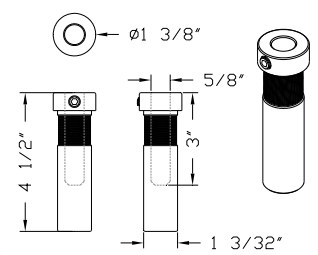



# Mag Cable Holders

**Part No:** MAG-CH3 (Single)  
**Sale price:** \$28.00  
**Material:** Aluminum  
**Color:** Black  
**Max. Capacity:** 35 lbs.  
**Weight:** 1 lb.  
**Dimensions:** D3 1/4" x W2 1/2" x H3 1/2"

**Shipping Weight/Dims:** 1 lb. (L9" x W5" x H5")

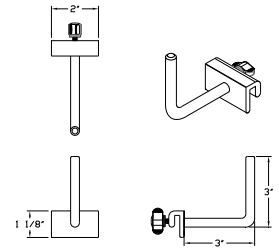
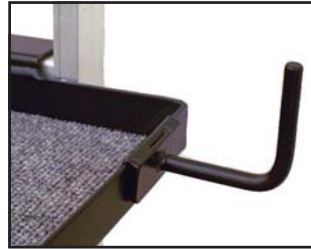

**Part No:** MAG-CH3S (Set 3-Hooks)  
**Sale price:** \$80.00  
**Material:** Aluminum  
**Color:** Black  
**Max. Capacity:** 75 lbs.  
**Weight:** 1 lb.  
**Dimensions:** D3 1/4" x W12" x H3 1/2"

**Shipping Weight/Dims:** 1 lb. (L5" x W5" x H13")

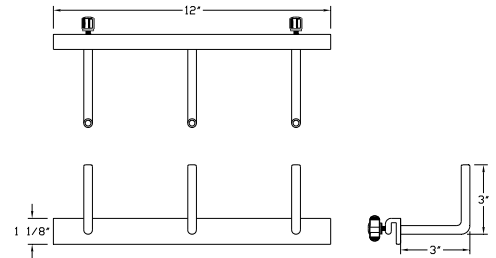

**Part No:** MAG-CH6 (J-Style Hook)  
**Sale price:** \$30.00  
**Material:** Aluminum  
**Color:** Black  
**Max. Capacity:** 35 lbs.  
**Weight:** 1 lb.  
**Dimensions:** D4 3/4" x W2 1/2" x H6"

**Shipping Weight/Dims:** 1 lb. (L9" x W5" x H5")

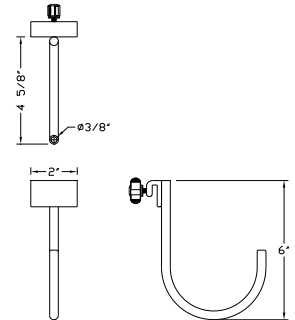

**Requirements:** MagTop Shelf (Mini, Junior or Senior, 18" or 24")  
**Conflicts:** None  
**Suggestions:** Mag Headphone Holder, Mag Utility Box

# Mag Headphone Holder

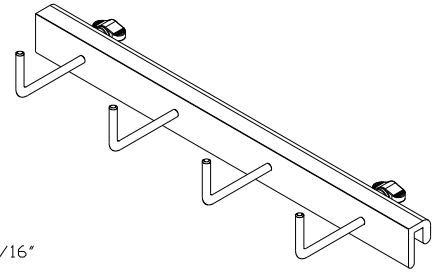
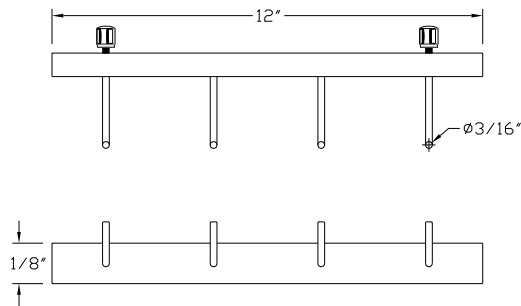

**Part No:** MAG-CHHS  
**Sale price:** \$ 75.00  
**Material:** Aluminum  
**Color:** Black  
**Max. Capacity:** 50 lbs.  
**Weight:** 1 lb.  
**Dimensions:** D2 1/2" x W12" x H1 3/4"

Shipping Weight/Dims: 1 lb. (L5" x W5" x H13")



**Requirements:** Mag Top Shelf (Magliner Junior or Senior, 18" or 24")  
**Conflicts:** None  
**Suggestions:** Mag 3" Cable Holder, Mag 6" Cable Holder, Mag Utility Box

## Mag Bag

**Part No:** MAG-B  
**Sale price:** \$ 95.00  
**Material:** Cloth  
**Color:** Black, Blue, Red or Green  
**Max. Capacity:** 50 lbs.  
**Weight:** 2 lbs.  
**Dimensions:** W23 1/2" x H29 1/2"

**Shipping Weight/Dims:** 2 lbs. (L5" x W5" x H25")



**Requirements:** None  
**Conflicts:** Mag Battery Holder, Mag Hi/Lo Hat Holder, Mag C-Stand Holder (4), Mag Mitchell Mount, Mag Dove Tail Mount  
**Suggestions:** Mag Ditty Bag, Mag Utility Box



## Mag Ditty Bag

**Part No:** MAG-B CE  
**Sale price:** \$ 175.00  
**Material:** Cloth  
**Color:** Blue, Red, \*Black (\*Not available for Japan)  
**Max. Capacity:** 50 lbs.  
**Weight:** 2 lbs.  
**Dimensions:** D7" x W18" x H18"

**Shipping Weight/Dims:** 3 lbs. (L7" x W7" x H25")



**Requirements:** Mag Grip Handles  
**Conflicts:** Magliner Senior (Stock), Mag Battery Holder, Mag Hi/Lo Hat Holder, Mag C-Stand Holder (4)  
**Suggestions:** Mag Bag, Mag Utility Box



## Mag Computer Keyboard Tray

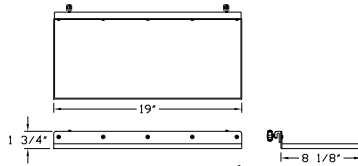

Part No: MAG-K  
 Sale price: \$ 135.00  
 Material: Aluminum  
 Color: Black/Grey (Carpet)  
 Max. Capacity: 20 lbs.  
 Weight: 3 lbs.  
 Dimensions: D8" x W19" x H1"

Shipping Weight/Dims: 3 lbs. (L21" x W10" x H3")

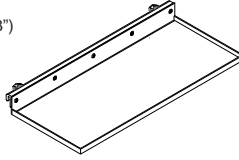

Requirements: Mag Top Shelf (Mag Mini, Junior, Senior, 18" or 24")

Conflicts: None

Suggestions: Mag 28" Keyboard and Mouse Tray, Mag Lap Top Tray, Mag Dual Video Monitor Bracket, Mag Nose Pin with 5/8" Baby Pin (Ctr.), Mag Nose Pin with 5/8" Baby Pin (Offset)

## Mag Computer Keyboard and Mouse Tray

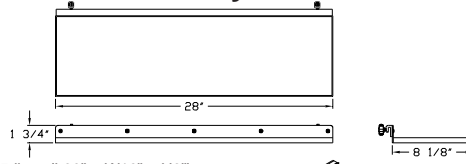

Part No: MAG-KM  
 Sale price: \$ 145.00  
 Material: Aluminum  
 Color: Black/Gray (Carpet)  
 Max. Capacity: 20 lbs.  
 Weight: 4 lbs.  
 Dimensions: D8" x W28" x H1"

Shipping Weight/Dims: 5 lbs. (L30" x W10" x H3")

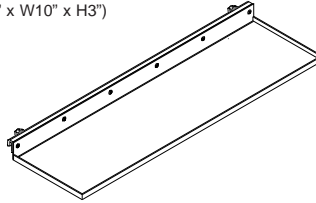

Requirements: Mag Top Shelf

Conflicts: None

Suggestions: Mag Lap Top Tray, Mag Lunch Tray

# Mag Lunch Tray with Cup Holder

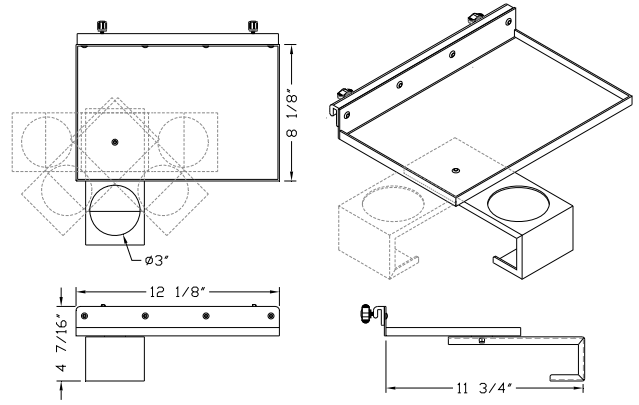

**Part No:** MAG-Q  
**Sale price:** \$ 125.00  
**Material:** Aluminum  
**Color:** Black  
**Max. Capacity:** 10 lbs.  
**Weight:** 2 lbs.  
**Dimensions:** D8 1/8" x W12 1/8" x H3 1/2"

**Shipping Weight/Dims:** 3 lbs. (L13" x W10" x H5")



**Requirements:** Mag Top Shelf  
**Conflicts:** None  
**Suggestions:** Mag Cup Holder, Mag Umbrella

## Mag Cup Holder with Bracket

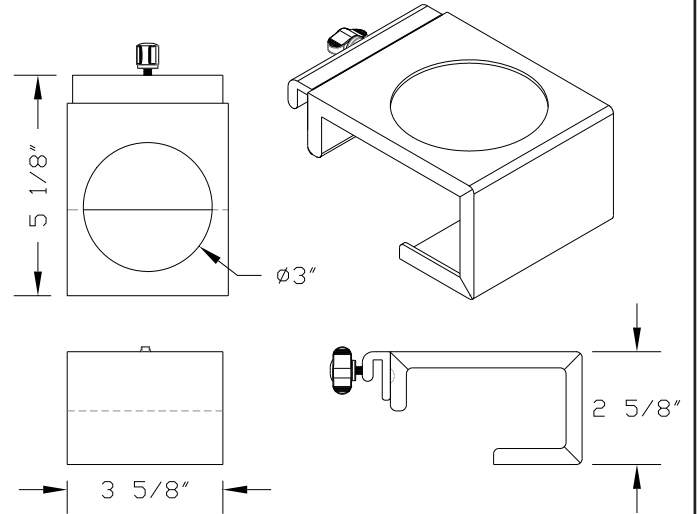

Mounts and locks on outside lip of any Magliner Shelf. Will hold cans and small bottles.

**Part No:** MAG-Q CH  
**Sale price:** \$ 62.00  
**Material:** Aluminum  
**Color:** Black  
**Max. Capacity:** 3 lbs.  
**Weight:** 1 lb.  
**Dimensions:** D4 3/4" x W4" x H2 5/8"

**Shipping Weight/Dims:** 1 lb. (L6" x W6" x H4")



**Requirements:** Mag Top Shelf (Mag Junior or Senior, 18" or 24")  
**Conflicts:** None  
**Suggestions:** Mag Lunch Tray, Mag Umbrella, Mag Keyboard Tray

## Mag Cup Holder (Foldable)

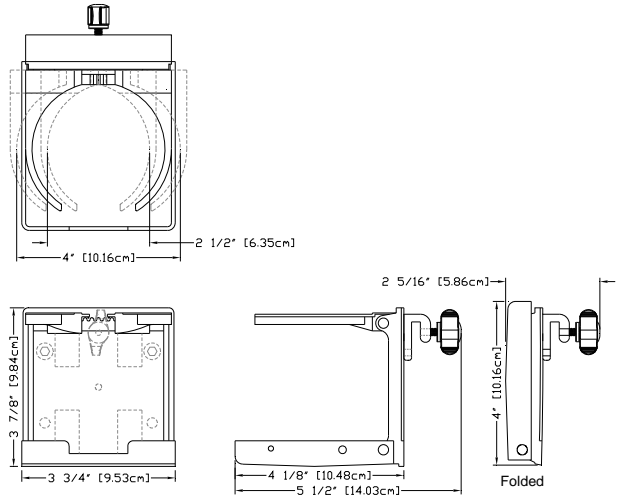

Mounts and locks on outside lip of any Magliner Shelf. Folds to a compact size. Cup Holder's width is adjustable from 2 1/2" - 4" (6.35cm - 10.16cm) Will hold cans and bottles.

**Part No:** MAG-Q CHF  
**Sale price:** \$30.00  
**Material:** Plastic/Aluminum  
**Color:** Black  
**Max. Capacity:** 3 lbs.  
**Weight:** 1 lb.  
**Dimensions:** D4 3/4" x W4" x H2 5/8"

**Shipping Weight/Dims:** 1 lb. (L5" x W5" x H3")



**Requirements:** Mag Top Shelf (Mag Mini, Junior or Senior, 18" or 24")  
**Conflicts:** None  
**Suggestions:** Mag Lunch Tray, Mag Umbrella, Mag Keyboard Tray



## Mag Roller Sliding Drawers with Lock

These drawers can be rack mounted or mounted underneath any Magliner Top Shelf. Both, Shelf and drawer are already pre-drilled for easy installation. (Hardware included)

**Note: If using multiple drawers, we can install matching key locks.**

Replacement lock (DRAWER LOCK-1) with two keys \$ 16.00

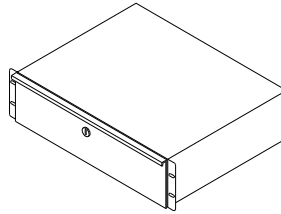

**Part No:** MAG-L2 PE-15

**Sale price:** \$ 175.00

**Material:** Steel

**Color:** Black

**Max. Capacity:** 50 lbs.

**Weight:** 15 lbs.

**Dimensions:** L15 3/4" x W19" x H3 1/2"  
(ID L14 1/2" x W16" x H2 7/8")

**Shipping Weight/Dims:** 17 lbs. (L21" x W20" x H7")

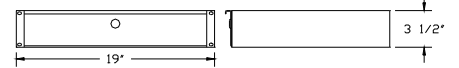
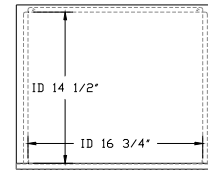

**Part No:** MAG-L3 PE-15

**Sale price:** \$ 190.00

**Material:** Steel

**Color:** Black

**Max. Capacity:** 50 lbs.

**Weight:** 17 lbs.

**Dimensions:** L15 3/4" x W19" x H4 5/8"  
(ID L14 1/2" x W16" x H4 5/8")

**Shipping Weight/Dims:** 20 lbs. (L21" x W20" x H9")

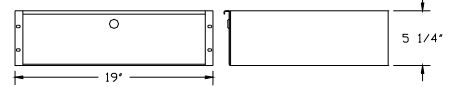
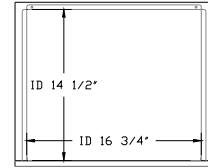

**Part No:** MAG-L4 PE-15

**Sale price:** \$ 215.00

**Material:** Steel

**Color:** Black

**Max. Capacity:** 50 lbs.

**Weight:** 19 lbs.

**Dimensions:** L15 3/4" x W19" x H7"  
(ID L14 1/2" x W19" x H6 3/8")

**Shipping Weight/Dims:** 22 lbs. (L21" x W20" x H11")

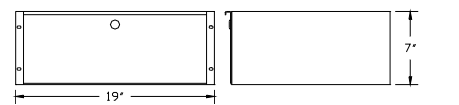
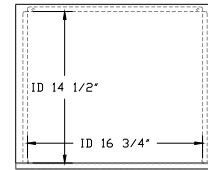

**Requirements:** Mag Top Shelf (Magliner Mini, Junior or Senior, 18" or 24"), Mag Vertical Drawer Shelf

**Conflicts:** Mag Utility Box 35", Mag Utility Box 46"

**Suggestions:** Mag Jockey Box



## Mag Mic Boom Grip & Base with Locking System (Large)



The Mic Boom Grip allows you to anchor your Mic Boom securely, preventing it from being dropped accidentally. To remove your Mic Boom, just push a spring loaded button located in the bottom of unit, this will release the locking system. The grip as well as the base can be set up anywhere along the lip of your shelf and tighten by hand. Accommodates any Mic Boom 1 1/8" to 1 1/2" in diameter.

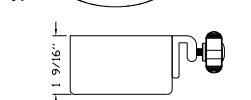
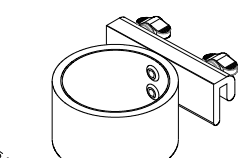
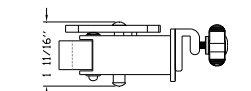
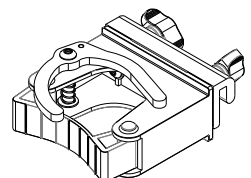
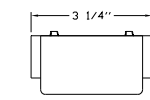
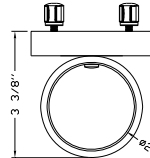
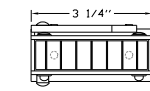
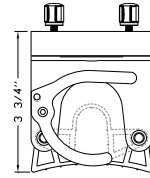

**Part No:** MAG-R4 LK-X

**Sale price:** \$ 140.00

**Material:** Aluminum/Plastic

**Color:** Black/Red

**Max. Capacity:** 25 lbs.

**Weight:** 1 lbs.

**Dimensions:** D4 5/16" x W3 1/4" x H1 11/16"

**Shipping Weight/Dims:** 1 lbs. (L9" x W5" x H3")



**Requirements:** Mag Top and Bottom Standard Shelf

**Conflicts:** Mag Keyboard Friendly Top Shelf

**Suggestions:** Mag U-Handle Cross Bar with Universal Receiver, Mag Sound Tray, Mag Middle Shelf, Mag 30" Nose (Adjustable), Mag Headphone Holder, Mag 3" Cable Holder

## Mag Mic Boom Grip & Base with Locking System (Small)



The Mic Boom Grip allows you to anchor your Mic Boom securely, preventing it from being dropped accidentally. To remove your Mic Boom, just push a spring loaded button located in the bottom of unit, this will release the locking system. The grip as well as the base can be set up anywhere along the lip of your shelf and tighten by hand. Accomodates any Mic Boom 3/4" to 1" in diameter.

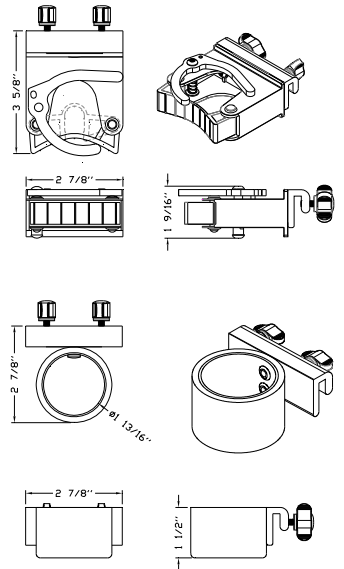

**Part No:** MAG-R2 LK-X  
**Sale price:** \$ 130.00  
**Material:** Aluminum/Plastic  
**Color:** Black/Blue  
**Max. Capacity:** 25 lbs.  
**Weight:** 1 lbs.  
**Dimensions:** D3 5/8" x W2 7/8" x H1 9/16"

**Shipping Weight/Dims:** 1 lbs. (L9" x W5" x H3")



**Requirements:** Mag Top and Bottom Standard Shelf

**Conflicts:** Mag Keyboard Friendly Top Shelf

**Suggestions:** Mag U-Handle Cross Bar with Universal Receiver, Mag Sound Tray, Mag Middle Shelf, Mag 30" Nose (Adjustable), Mag Headphone Holder, Mag 3" Cable Holder

## Mag U-Handle Cross Bar with Universal Receiver

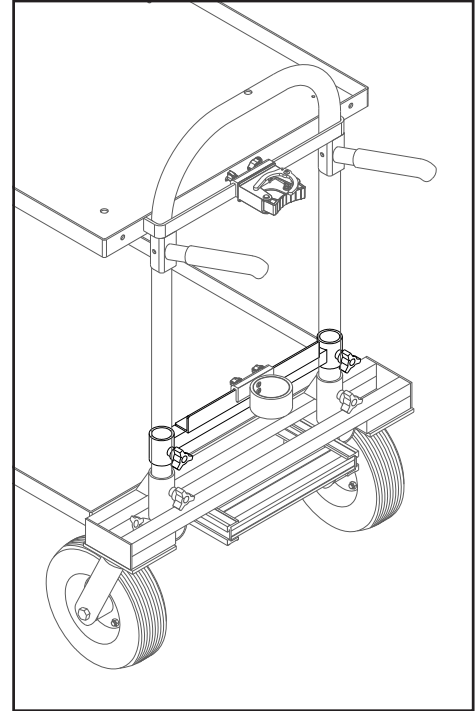
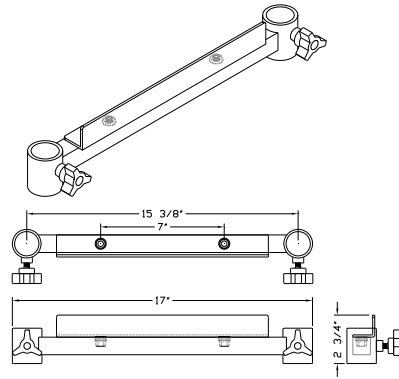

The Mag U-Handle Cross Bar with Universal Receiver was specifically made to hold a Mic Boom Grip & Base in a safe place. This accessory allows you to not only set the height, but also the horizontal position of your gear, you may install up to three (3) Mic Boom Grip & Base units side by side.

**Note:** When the Top Shelf U-Handle Bracket is being used or blocked by another accessory, you may use this unit to place additional Mag accessories equipped with a channel extrusion, such as Mag Cup Holders, Mag Cable Holder, Mag 10" Utility Box, Mag Lunch Tray, Mag Front Box Adapter, etc.

Part No: MAG-HU CB AL

Sale price: \$ 155.00

Material: Steel

Color: Black

Max. Capacity: 200 lbs.

Weight: 3 lbs.

Dimensions: D3" x W17" x H2 3/4"

Shipping Weight/Dims: 3 lbs. (L4" x W4" x H19")



### Requirements:

**Conflicts:** Mag C-Stand Holder (4), Mag Bag, Mag Ditty Bag, Mag Battery Holder, Mag Hi-Lo Hat Holder

**Suggestions:** Mag Mic Boom Grip & Base-4 with Locking System, Mag Sound Tray, Mag Middle Shelf, Mag 30" Nose (Adjustable), Mag Headphone Holder, Mag 3" Cable Holder,

Mag Mic Boom Grip mounted on Magliner Top Shelf and Mag Mic Boom Base mounted on Mag U-Handle with Universal Receiver.

# Mag Sand Dune Wheel Kit

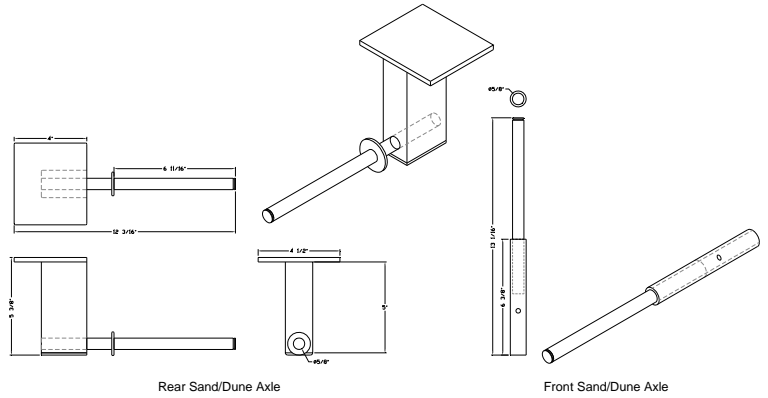

The Mag Sand/Dune Wheel Kit 24 includes four wheels and their respective special axes. Wheels are easily switched from pneumatic wheels to Sand/Dune wheels and vice versa. Model 24 is to be used on Magliner Junior and Senior outfitted with 24" wide shelves.

**Part No:** MAG-W 24  
**Sale price:** \$920.00  
**Material:** Steel  
**Color:** Black  
**Max. Capacity:** 480 lbs.  
**Weight:** 23 lbs.  
**Dimensions:** 12" Diam. x W39 1/2"

**Shipping Weight/Dims:** 24 lbs. (L23" x W18" x H13")

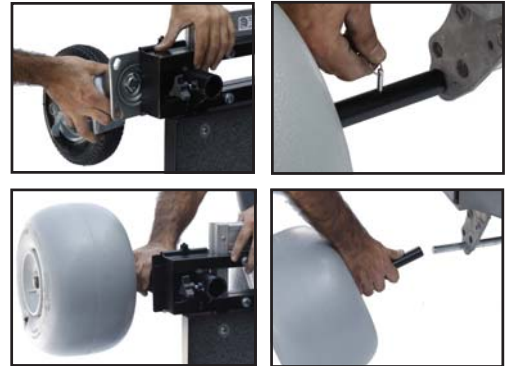

**Requirements:** Magliner Mini, Magliner Modified Junior or Senior with Mag 8" Wheel Conversion Kit (Standard)  
**Conflicts:** Mag Quad Axle Kit  
**Suggestions:** Mag Umbrella, Mag Umbrella Holder, Mag Nose 5/8" Baby Pin (Center or Offset)

## Mag Sand Dune Wheel Kit (Small)

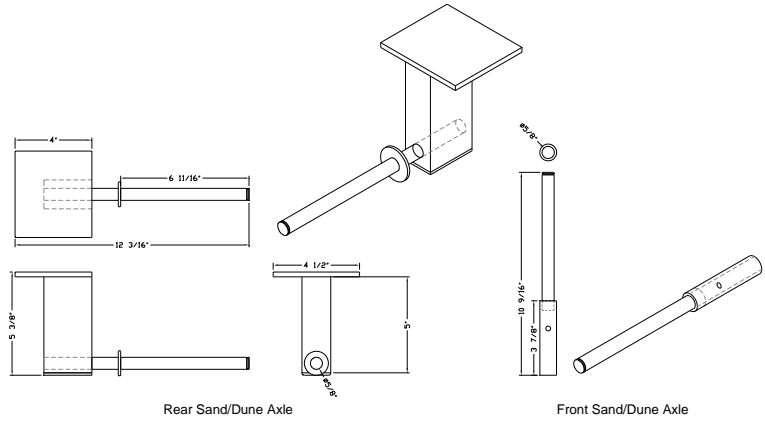

The Mag Sand/Dune Wheel Kit 18 includes four wheels and their respective special axles. Wheels are easily switched from Pneumatic wheels to Sand/Dune wheels and vice versa. Model 18 is to be used on Magliner Senior, Junior or Mini outfitted with 18" or 19" wide shelves.

**Part No:** MAG-W 18  
**Sale price:** \$910.00  
**Material:** Steel  
**Color:** Black  
**Max. Capacity:** 480 lbs.  
**Weight:** 23 lbs.  
**Dimensions:** 12" Diam. x W34 1/2"

**Shipping Weight/Dims:** 24 lbs. (L23" x W18" x H13")



**Requirements:** Modified Magliner Senior, Junior or Mini, Mag 8" Wheel Conversion Kit (Narrow or Mini)  
**Conflicts:** Mag Quad Axle Kit  
**Suggestions:** Mag Umbrella, Mag Umbrella Holder, Mag Nose 5/8" Baby Pin (Center or Offset)

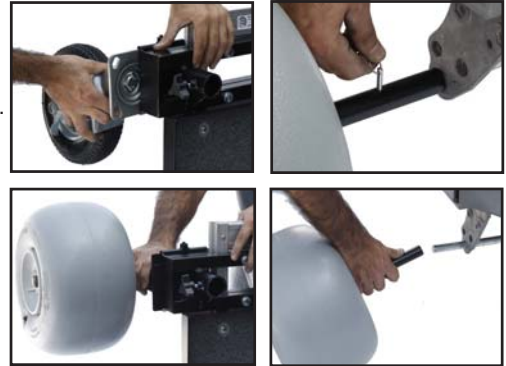

# Mag Jockey Box



**Part No:** MAG-J 24  
**Sale price:** \$ 435.00  
**Material:** Aluminum Diamond Plate  
**Color:** Black  
**Max. Capacity:** 150 lbs.  
**Weight:** 17 lbs.  
**Dimensions:** D24" x W21 1/2" x H7"  
 ID D22 5/8" x W19 1/8" x H5 5/16"

Shipping Weight/Dims: 18 lbs. (L27" x W25" x H9")

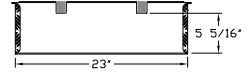
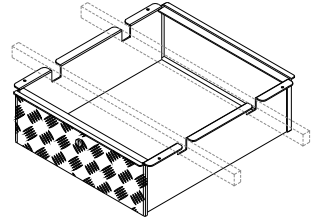
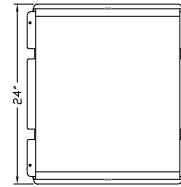

**Requirements:** Mag Junior (Modified) or Mag Senior (Modified) with 24" wide Bottom Shelf  
**Conflicts:** Mag U-Handle (Upright mode only), Mag Twin Axle Kit  
**Suggestions:** Mag 2, 3 or 4-Space Roller Sliding Drawer with Lock, Mag Grip/Light Caddy

**Part No:** MAG-J 18  
**Sale price:** \$ 405.00  
**Material:** Aluminum Diamond Plate  
**Color:** Black  
**Max. Capacity:** 150 lbs.  
**Weight:** 15 lbs.  
**Dimensions:** D18" x W21 1/2" x H7"  
 ID D16 5/8" x W19 1/8" x H5 5/16"

Shipping Weight/Dims: 16 lbs. (L23" x W19" x H9")

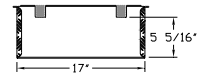
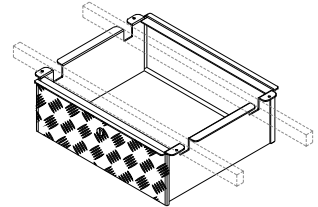
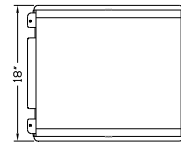

**Requirements:** Mag Junior (Modified) or Mag Senior (Modified) with 18" wide Bottom Shelf  
**Conflicts:** Mag U-Handle (Upright mode only), Mag Twin Axle Kit  
**Suggestions:** Mag 2, 3 or 4-Space Roller Sliding Drawer with Lock, Mag Grip/Light Caddy

# Mag Monitor Video Dual Bracket

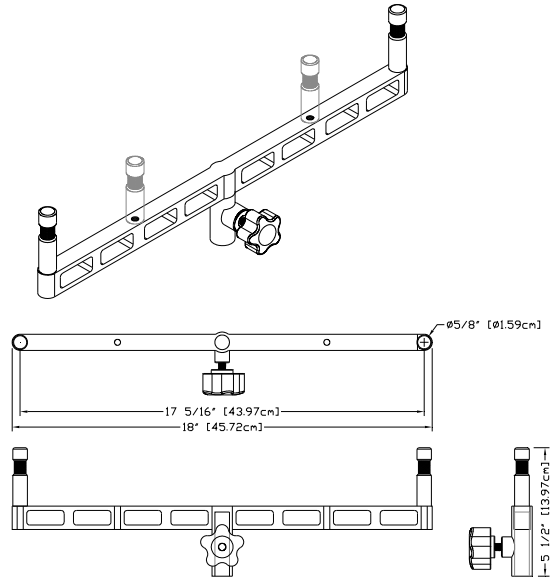

**Part No:** MAG-V  
**Sale price:** \$ 170.00  
**Material:** Aluminum  
**Color:** Black  
**Max. Capacity:** 40 lbs.  
**Weight:** 2 lbs.  
**Dimensions:** D18 13/16" x W2 5/8" x H5 1/2"

**Shipping Weight/Dims:** 2 lbs. (L19" x W7" x H5")



**Requirements:** Mag U-Handle 5/8" Baby Pin, Mag Nose 5/8" Baby Pin (Ctr.), Mag Nose 5/8" Baby Pin (Offset), Mag Tripod Holder with 5/8" Baby Pin  
**Conflicts:** Mag Sound Tray  
**Suggestions:**

## Mag Monitor Video Dual Bracket (Telescopic)



Same as the Mag Video Dual Bracket in size, but able to adjust the width depending on the size of the monitors you are using. There's three presets with built-in push buttons for quick release and lock. Unit also has hand prongs should you need a specific width. Unit extends from 16 1/2 inches to 24 inches. (Pin to Pin)

**Part No:** MAG-VT  
**Sale price:** \$ 245.00  
**Material:** Steel  
**Color:** Black  
**Max. Capacity:** 40 lbs.  
**Weight:** 3 lbs.  
**Dimensions:** D18 1/4" x W2" x H5 1/8"

**Shipping Weight/Dims:** 4 lbs. (L19" x W7" x H5")

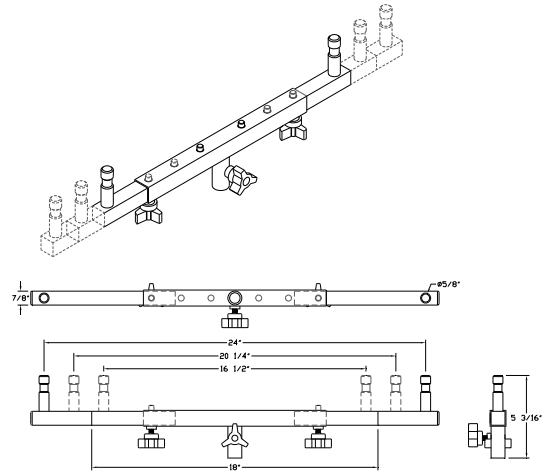

Mag Video Dual Bracket (Telescopic) fully extended

**Requirements:** Mag U-Handle 5/8" Baby Pin, Mag Nose 5/8" Baby Pin (Ctr.), Mag Nose 5/8" Baby Pin (Offset), Mag Nose 5/8" Baby Pin (Side), Mag Tripod Holder with 5/8" Baby Pin  
**Conflicts:** Mag Sound Tray  
**Suggestions:**



## Mag Flat Screen Video Dual Baby Riser (Adj.) with 5/8" Baby Pin

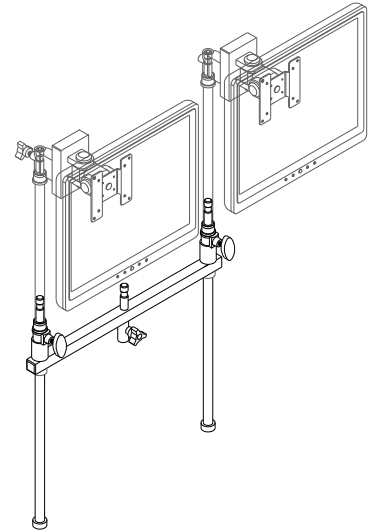
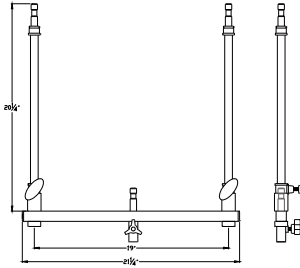

**Part No:** MAG-VPR

**Sale price:** \$ 405.00

**Material:** Steel

**Color:** Black

**Max. Capacity:** 40 lbs.

**Weight:** 5 lbs.

**Dimensions:** D1 3/8" x W24" x H21 3/4"

**Shipping Weight/Dims:** 5 lbs. (L5" x W5" x H25")



**Requirements:** Mag U-Handle 5/8" Baby Pin or Mag Nose 5/8" Baby Pin (Ctr.) or Mag Nose 5/8" Baby Pin (Offset) or Mag Tripod Holder with 5/8" Baby Pin

**Conflicts:** Mag Sound Tray

**Suggestions:** Mag LCD Tilt Head, Mag LCD 4"/6"/8" Tilt Head Adapter

# Mag Junior Monitor Horizontal Cross Bar

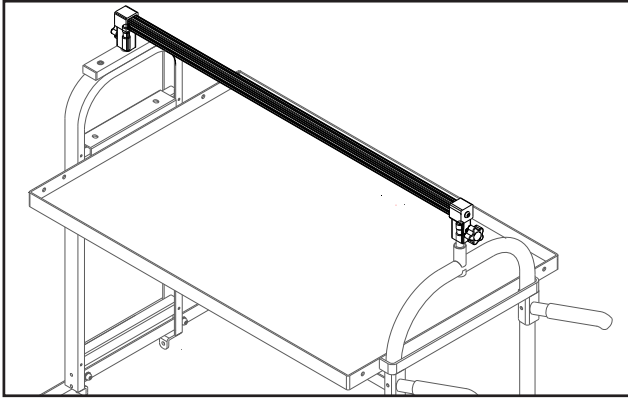

Unit anchors to two 5/8" Baby Pins at each end of the cart (MAG-NP CTR and MAG-S). You can use as many "Slide-On" 5/8" Baby Pins (MAG-SHP) to run along the length of the bar allowing you to install up to three (3) 17" Monitors side by side. (MAG SHP not included)  
**Note: You may offset the Monitor Horizontal Cross Bar 9 3/4 inches towards the back or front of the cart by using two Offset Arms (MAG-V OS)**

**Part No:** MAG-SH JR  
**Sale price:** \$ 146.00  
**Material:** Steel  
**Color:** Black  
**Max. Capacity:** 50 lbs.  
**Weight:** 4 lbs.  
**Dimensions:** L42 1/2" x W1 1/2" x H2 5/8"

**Shipping Weight/Dims:** 4 lbs. (L5" x W5" x H45")



**Part No:** MAG-NP CTR \$ 81.00 (Page 79)  
**Part No:** MAG-S \$ 89.00 (Page 84)  
**Part No:** MAG-V OS \$ 225.00 (Page 33)

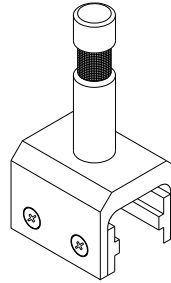

**Slide-On 5/8" Baby Pin**  
**Part No:** MAG-SHP  
**Sale price:** \$ 75.00

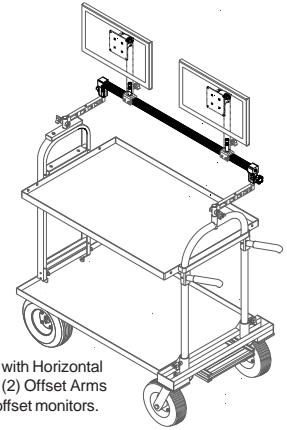
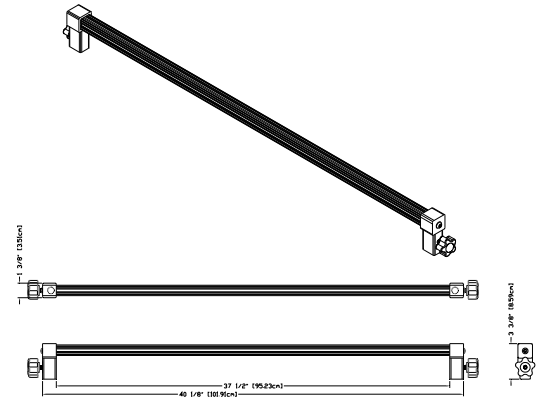

Mag Mini shown with Horizontal Cross Bar using (2) Offset Arms (MAG-V OS) to offset monitors.

**Requirements:** Mag U-Handle 5/8" Baby Pin and Mag 5/8" Nose Pin (Center) or Mag Tripod Holder with 5/8" Baby Pin  
**Conflicts:** Mag Sound Tray  
**Suggestions:** Mag Offset Arm (MAG-V OS), Mag VESA Tilt Head (LD, MD, HD), Mag LCD 4", 8" or 12" Tilt Head Pin Adapter, Mag Baby Spud 4", 6" or 8" Extension

## Mag Senior Monitor Horizontal Cross Bar



Unit anchors to two 5/8" Baby Pins at each end of the cart (MAG-NP CTR and MAG-S). You can use as many "Snap-On" 5/8" Baby Pins (TR-04 SHP) to run along the length of the bar allowing you to install up to three (3) 24" Monitors side by side. (TR-04 SHP not included)

**Note: You may offset the Monitor Horizontal Cross Bar 9 3/4 inches towards the back or front of the cart by using two Offset Arms (MAG-V OS) See drawing on page 109.**

**Part No:** MAG-SH SR

**Sale price:** \$ 157.00

**Material:** Steel

**Color:** Black

**Max. Capacity:** 50 lbs.

**Weight:** 4 lbs.

**Dimensions:** L54 1/8" x W1 1/2" x H2 5/8"

**Shipping Weight/Dims:** 5 lbs. (L5" x W5" x H55")



**Part No:** MAG-NP CTR \$ 81.00 (Page 79)

**Part No:** MAG-S \$ 89.00 (Page 84)

**Part No:** MAG-V OS \$ 225.00 (Page 33)

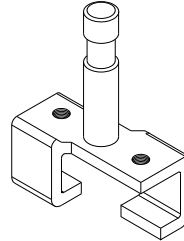
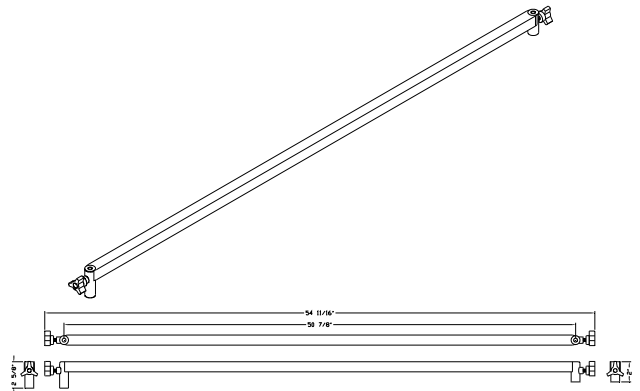

**Snap-On 5/8" Baby Pin**

**Part No:** TR-04-SHP

**Sale price:** \$ 55.00

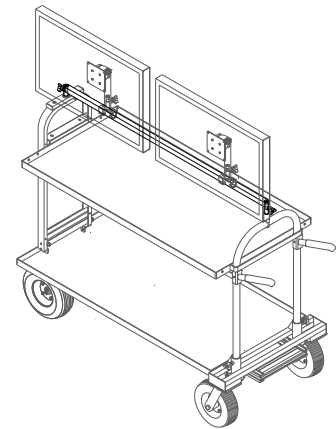

**Requirements:** Mag U-Handle 5/8" Baby Pin and Mag 5/8" Nose Pin (Center) or Mag Tripod Holder with 5/8" Baby Pin

**Conflicts:** Mag Sound Tray

**Suggestions:** Mag Offset Arm (MAG-V OS), Mag VESA Tilt Head (LD, MD, HD), Mag LCD 4", 8" or 12" Tilt Head Pin Adapter, Mag Baby Spud 4", 6" or 8" Extension

## Mag LCD LD Monitor Arm (Black)



The LCD Arms (HD, MD & LD) accommodate big LCD monitors and flat panel displays. You'll never twist a knob or push a lever. Simply float your plasma or LCD monitor with fingertip ease from one position to another. Tilt Head allows screen rotation from landscape to portrait mode and tilts back past 90 degrees or downward 44 degrees. Arm is easily removed from cart by loosening hand prong.

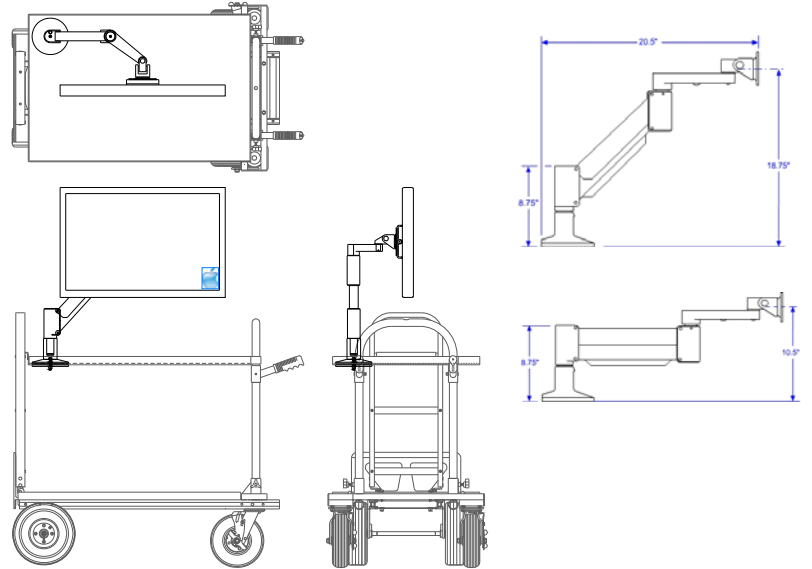

Mag Monitor Arm, Mag HD Thru Desk Mount & Mag HD Thru Desk Support Plate shown with 30" Apple Cinema display mounted on Modified Mag Junior

**Part No:** MAG-LCD LD-MA BK-X

**Sale price:** \$ 475.00

**Material:** Steel

**Color:** Black

**Max. Capacity:** 9-23 lbs.

**Weight:** 10 lbs.

**Dimensions:** N/A

**Shipping Weight/Dims:** 11 lbs. (L19" x W15" x H5")



**Note:** Weight of monitor determines which arm to use. MAG-LCD MD-MA BK-X (Cap. 12-38 lbs) \$ 645.00, MAG-LCD HD-MA BK-X (Cap. 24-55 lbs.) \$ 880.00

**Requirements:** Mag Top Shelf, Mag Top Shelf Safety Lock

**Conflicts:** Mag Sound Tray

**Suggestions:** Mag Lap Top Tray, Mag LCD Tilt Head, Mag LCD Tilt Head, Mag LCD 4"/6"/8" Tilt Head Adapter, Mag HD Tent

# Mag LCD Tilt Head

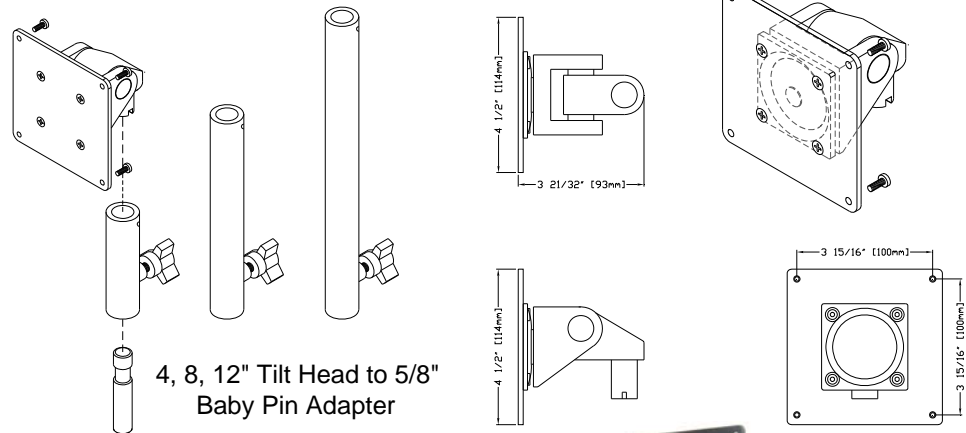

4, 8, 12" Tilt Head to 5/8" Baby Pin Adapter

The LCD Tilt Head allows you to install any LCD Monitor to its 100mm VESA Plate. Tilt Head allows screen rotation from landscape to portrait mode, tilts back past 90 degrees or downward 44 degrees. Tilt Head's resistance is adjustable. Available for Light Duty, Medium Duty and Heavy Duty applications.

**Note: Requires Tilt Head Pin Adapter for installation to a standard 5/8" Baby Pin.**

**Part No:** MAG-LCD TH-LD BK-X  
**Sale price:** \$ 98.00  
**Material:** Steel  
**Color:** Black  
**Max. Capacity:** 0-35 lbs.  
**Weight:** 2 lbs.  
**Dimensions:** D3 1/2" x W4 1/2" x H4 1/2"

**Shipping Weight/Dims:** 3 lbs. (L11" x W7" x H5")



MAG-LCD MR-04 Mag LCD Tilt Head 4" Pin Adapter \$ 50.00  
 MAG-LCD MR-08 Mag LCD Tilt Head 8" Pin Adapter \$ 60.00  
 MAG-LCD MR-12 Mag LCD Tilt Head 12" Pin Adapter \$ 70.00  
**MAG-LCD TH MD-BK-X Medium Duty 20-35 lbs. \$ 125.00**  
**MAG-LCD TH HD-BK-X Heavy Duty 15-55 lbs. \$ 145.00**

**Requirements:** Mag LCD 4", 8" or 12" Tilt Head Pin Adapter

**Conflicts:**

**Suggestions:** Mag 5/8" Nose Pin (Center), Mag 5/8" Nose Pin (Off Set), Mag U-Handle 5/8" Baby Pin



Mag LCD Tilt Head with 4" Tilt Head to 5/8" Baby Pin Adapter

# Mag LCD HD Monitor Arm U-Handle Adapter

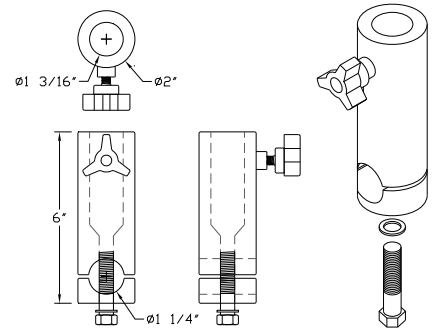

The Mag LCD U-Handle Mount has a special receiver to anchor any of our new LCD Monitor Arms. It's held on by a high grade 1/2" diameter bolt that fits into any Modified Magliner Cart with a pre-drilled U-Handle.

**Part No:** MAG-LCD HD-MA HU  
**Sale price:** \$ 105.00  
**Material:** Aluminum  
**Color:** Black  
**Max. Capacity:** 75 lbs.  
**Weight:** 1.5 lbs.  
**Dimensions:** Diam. 2" x H5 7/8"

**Shipping Weight/Dims:** 2 lbs. (L9" x W5" x H3")



30" Apple Cinema Display with HD Monitor Arm mounted on U-Handle LCD Mount

**Requirements:** Magliner Senior (Modified), Magliner Junior (Modified), Magliner Mini

**Conflicts:** Mag Sound Tray

**Suggestions:** Mag Monitor Arm Nose Adapter, Mag Lap Top Tray, Mag LCD Tilt Head, Mag LCD 4"/6"/8" Tilt Head Adapter, Mag HD Tent

## Mag LCD HD Monitor Arm Nose Adapter



The Mag LCD Nose Adapter bolts right into any of our pre-drilled Mag HD Noses, it uses the same standard bolt pattern. The special aluminum plate will allow you to dock any of our LCD Monitor Arms.

**Part No:** MAG-LCD HD-MA N  
**Sale price:** \$95.00  
**Material:** Aluminum  
**Color:** Black  
**Max. Capacity:** 75 lbs.  
**Weight:** 10 oz.  
**Dimensions:** D4 1/8" x W6 1/2" x H3/8"

**Shipping Weight/Dims:** 1 lb. (L9" x W5" x H3")



**Requirements:** Mag HD 30" Nose, Mag HD 30" Nose (Adjustable), Mag 18" or 24" Top Shelf, Mag LCD Arm Desk Mount Column Receiver  
**Conflicts:** Mag Sound Tray  
**Suggestions:** Mag Monitor Arm U-Handle Adapter, Mag Lap Top Tray, Mag Flat Screen VESA Plate Adapter with 5/8" Baby Receiver, Mag HD Tent

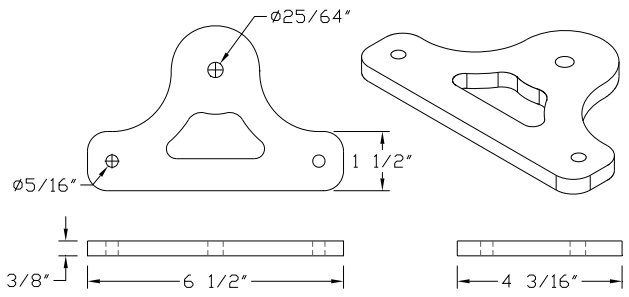

Mag LCD Monitor Arm Nose Adapter with Monitor Arm Thru Desk Mount receiver.  
**Part No:** MAG-LCD DMR \$ 48.00



30" Apple Cinema Display with HD Monitor Arm mounted on Nose LCD Adapter

## Mag Twin Axle Kit

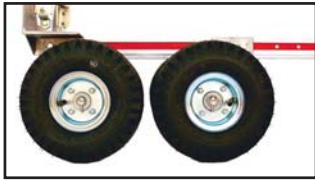

**Part No:** MAG-Y 5/8-18X  
**Sale price:** \$ 165.00  
**Material:** Steel  
**Color:** Clear Zinc Plate  
**Max. Capacity:** 500 lbs.  
**Weight:** 13 lbs.  
**Dimensions:** Diam. 10 1/2" x W20 3/4"



**Shipping Weight/Dims:** 13 lbs. (L25" x W13" x H5")  

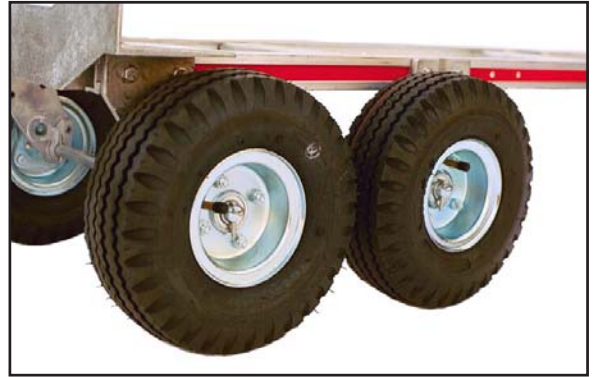



**Requirements:** Mag Junior (Modified), Mag Senior (Modified)  
**Conflicts:** Mag Jockey Box  
**Suggestions:** Mag Front Dual 8" Wheels, Mag Grip/Light Caddy

## Mag Quad Axle Kit

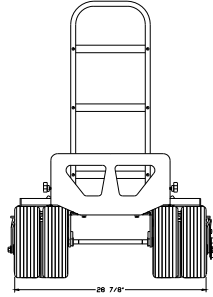

**Part No:** MAG-Y 34X  
**Sale price:** \$ 205.00  
**Material:** Steel  
**Color:** Clear Zinc Plate  
**Max. Capacity:** 500 lbs.  
**Weight:** 15 lbs.  
**Dimensions:** Diam. 10 1/2" x W28 7/8"



**Shipping Weight/Dims:** 17 lbs. (L25" x W13" x H7")  



**Requirements:** Mag Junior (Modified), Mag Senior (Modified)  
**Conflicts:** Mag Sand/Dune Wheel Kit Front 5/8" Axles  
**Suggestions:** Mag Front Dual 8" Wheels, Mag Grip/Light Caddy



# Mag Junior Vertical Cart with 5" Wheel Conversion Kit



Cart comes equipped with 10" rear Pneumatic Wheels and 5" front Thermal Swivel Caster Wheels with Brakes, Push Handles and lockable Jockey Box with built-in carpeted Shelf with gas lift support strut prop rod.



Mag Vertical Cart shown with optional Mag Vertical Utility Tray and Mag Vertical Shelf.

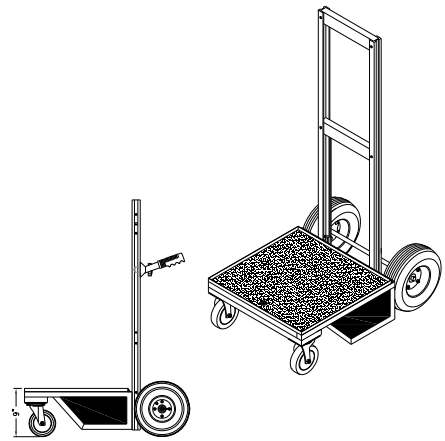
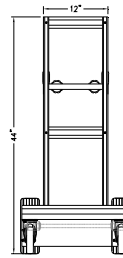
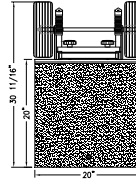

Basic Mag Vertical Cart. The shelves as well as all other accessories are easily adjusted and attached by use of knobs. We provide a full line of accessories for sound, video & remote head technicians.

- Adjustable Handles
- Large Toe Plate (D12" x W14")
- (2) 10" Pneumatic Wheels

**MAG-01 V-JR**  
26 lbs. D23" x W20 3/4" x H44"  
**Sale Price \$ 645.00**



**Part No:** MAG-01 V-JR 5X  
**Sale price:** \$ 1,275.00  
**Material:** Aluminum/Steel  
**Color:** Natural Aluminum/Black  
**Max. Capacity:** 500 lbs.  
**Weight:** 58 lbs.  
**Dimensions:** D30 11/16" x W20 1/2" x H44"

**Shipping Weight/Dims:** 65 lbs. (L16" x W26" x H45")



**Requirements:** None

**Conflicts:** None

**Suggestions:** Mag Vertical Shelf, Mag Vertical Nagra Shelf, Mag Keyboard/Mouse Tray, Mag Vertical Dual Baby Riser, Mag Umbrella, Mag Vertical 5/8" Baby Pin

# Mag Junior Vertical Cart with 8" Wheel Conversion Kit

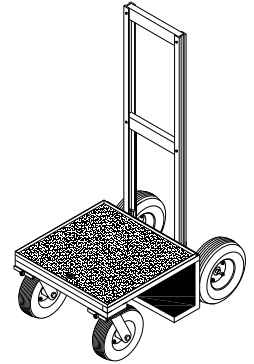
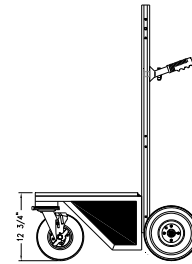
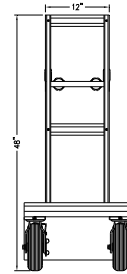
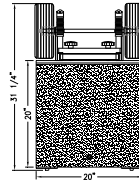

Cart comes equipped with 10" rear pneumatic wheels, 8" front pneumatic wheels with brakes, Push Handles and lockable Jockey Box with built-in carpeted Shelf with gas lift support strut prop rod.

**Part No:** MAG-01 V-JR 8X  
**Sale price:** \$ 1,425.00  
**Material:** Aluminum/Steel  
**Color:** Natural Aluminum/Black  
**Max. Capacity:** 500 lbs.  
**Weight:** 71 lbs.  
**Dimensions:** D31 1/4" x W20 1/2" x H48"

**Shipping Weight/Dims:** 78 lbs. (L16" x W26" x H49")



**MAG-W 24** Mag Sand/Dune Wheel Kit \$ 920.00  
**MAG-01 VLW** Mag Vertical Loading Wheel Set \$ 255.00

**Requirements:** None  
**Conflicts:** None  
**Suggestions:** Mag Vertical Shelf, Mag Sliding Tray, Mag Nagra Tray, Mag Sand/Dune Wheel Kit, Mag Utility Tray, Mag Antenna Riser, Mag Umbrella, Mag DIT HD Tent



Mag Vertical Junior shown in lay-down position with optional Loading Wheels.

## Mag Vertical 5" Wheel Conversion Kit



The Mag Vertical 5" Wheel Conversion Kit can be adapted to any Magliner Cart. The 5" Thermal Swivel Casters with Brakes are an excellent option when looking for additional stability for your vertical cart. The 5" caster wheels are great when working on stage or any location with an even surface. Unit includes a lockable Jockey Box with a built-in carpeted shelf with gas lift support strut prop rod.

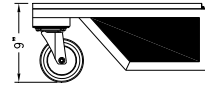
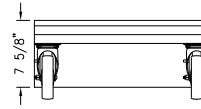
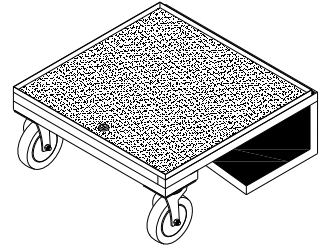
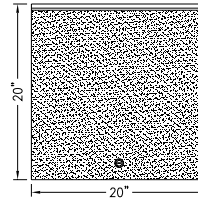

**Part No:** MAG-01 VE-5  
**Sale price:** \$ 775.00  
**Material:** Steel  
**Color:** Black  
**Max. Capacity:** 500 lbs.  
**Weight:** 38 lbs.  
**Dimensions:** D20" x W20" x H9"

**Shipping Weight/Dims:** 40 lbs. (L21" x W21" x H11")



**Requirements:** Mag Vertical Cart  
**Conflicts:** None  
**Suggestions:** Mag Vertical Shelf, Mag Vertical Sliding Shelf, Mag Vertical Drawer Shelf, Mag Vertical Nagra Shelf, Mag Vertical Utility Tray, Mag Vertical Loading Wheels

# Mag Vertical 8" Wheel Conversion Kit

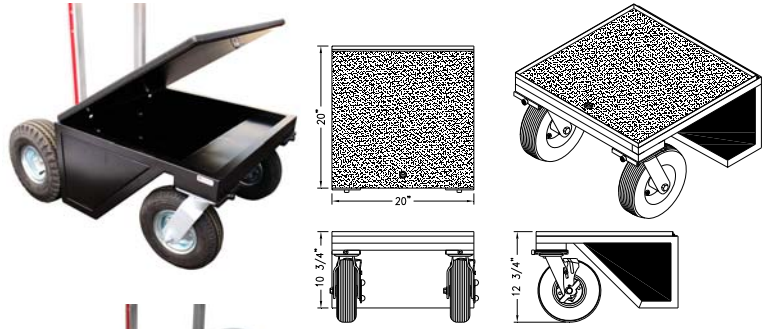

The Mag Vertical 8" Wheel Conversion Kit can be adapted to any Magliner Cart. The 8" Pneumatic Swivel Caster Wheels with Brakes work quite well in areas where dirt, gravel, pebbles and grass are a problem for standard wheels. Wheels can be removed and switched with optional Sand/Dune wheels when working on the sand, snow, golf courses and cable infested areas. Unit includes a lockable Jockey Box with a built-in carpeted shelf with gas lift support strut prop rod.

**Part No:** MAG-01 VE-8  
**Sale price:** \$ 925.00  
**Material:** Steel  
**Color:** Black  
**Max. Capacity:** 500 lbs.  
**Weight:** 49 lbs.  
**Dimensions:** D20 5/8" x W20" x H13"

**Shipping Weight/Dims:** 55 lbs. (L25" x W21" x H15")



**MAG-W 24** Mag Sand/Dune Wheel Kit \$ 920.00

**Requirements:** Mag Vertical Cart  
**Conflicts:** None  
**Suggestions:** Mag Vertical Shelf, Mag Vertical Sliding Shelf, Mag Vertical Drawer Shelf, Mag Vertical Nagra Shelf, Mag Vertical Utility Tray, Mag Sand/Dune Wheel Kit

## Mag Junior Vertical Cart with 5" Wheels and Low Profile Base

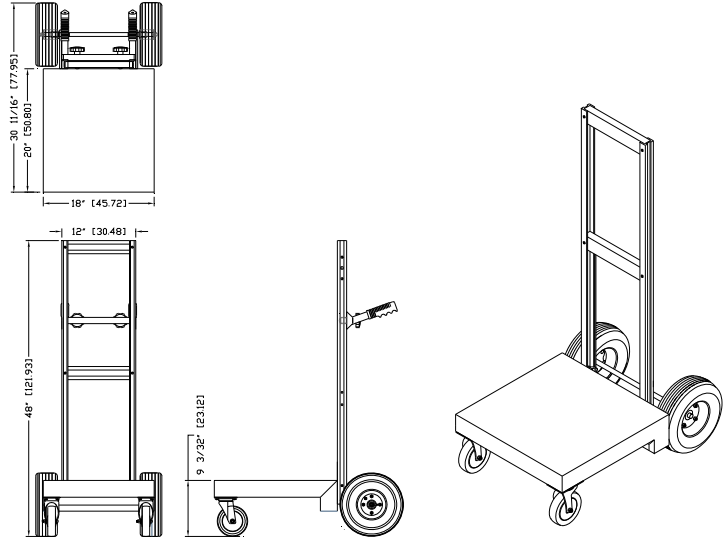

The Mag Vertical with 5" Wheels and Low Profile Base is almost identical to the Standard 5" Vertical Cart except it has no Jockey Box and no AC options. This the perfect cart to mount a SKB Case.

**Part No:** MAG-01 V-JR LP-5X  
**Sale price:** \$ 995.00  
**Material:** Aluminum  
**Color:** Black  
**Max. Capacity:** 500 lbs.  
**Weight:** 36 lbs.  
**Dimensions:** D30 11/16" x W20 1/2" x H48"

**Shipping Weight/Dims:** 43 lbs. (L16" x W26" x H49")



**Requirements:**

**Conflicts:** None

**Suggestions:** Mag Vertical Shelf, Mag Vertical Sliding Shelf, Mag Vertical Drawer Shelf, Mag Vertical Nagra Shelf, Mag Vertical Utility Tray

## Mag Junior Vertical Cart with 8" Wheels and Low Profile Base

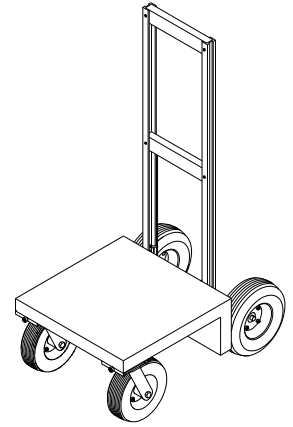
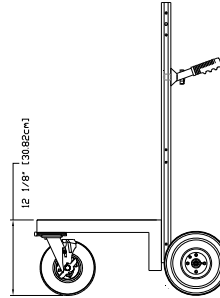
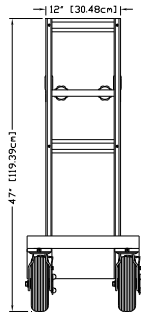
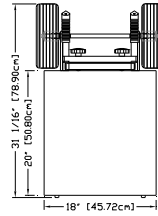

The Mag Vertical with 8" Wheels and Low Profile Base is almost identical to the Standard 8" Vertical Cart except it has no Jockey Box and no AC options. This is the perfect cart to mount a SKB Case. The 8" Pneumatic Swivel Caster Wheels with Brakes work quite well in areas where dirt, gravel, pebbles and grass are a problem for standard wheels. Wheels can be removed and switched with optional Sand/Dune wheels when working on the sand, snow, golf courses and cable infested areas.

**Part No:** MAG-01 V-JR LP-8X  
**Sale price:** \$ 1,095.00  
**Material:** Aluminum  
**Color:** Black  
**Max. Capacity:** 500 lbs.  
**Weight:** 49 lbs.  
**Dimensions:** D31 1/16" x W20 1/2" x H48"

**Shipping Weight/Dims:** 56 lbs. (L32" x W21" x H49")



**Requirements:**

**Conflicts:** None

**Suggestions:** Mag Vertical Shelf, Mag Vertical Sliding Shelf, Mag Vertical Drawer Shelf, Mag Vertical Nagra Shelf, Mag Vertical Utility Tray, Mag Sand/Dune Wheel Kit

## Mag Vertical Loading Wheel Set

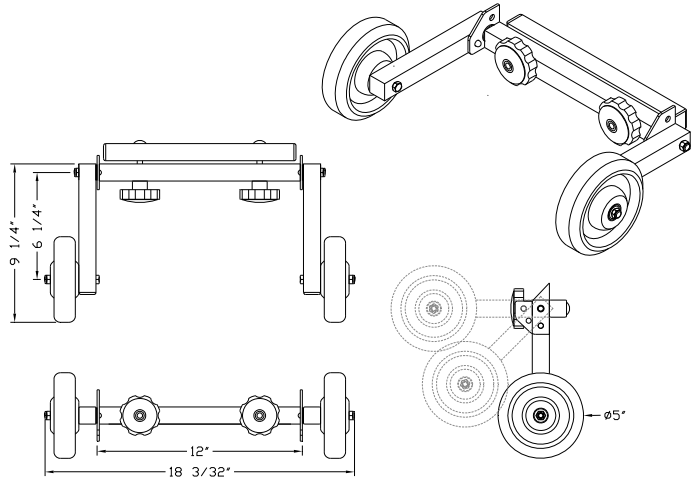

The Mag Vertical Loading Wheels can be adapted to any Magliner Vertical Cart. Kit can be installed, removed or adjusted very quickly without the use of tools, you just tighten or loosen unit with a pair of Hand Prongs. Unit is foldable when not in use.

**Part No:** MAG-01 VLW

**Sale price:** \$255.00

**Material:** Steel

**Color:** Black

**Max. Capacity:** 250 lbs.

**Weight:** 5 lbs.

**Dimensions:** D10 1/2" x W18 3/32" x H5" (ea.)

**Shipping Weight/Dims:** 6 lbs. (L19" x W11" x H7")



**Requirements:** Mag Vertical Cart

**Conflicts:** None

**Suggestions:** Mag Vertical Shelf, Mag Vertical Sliding Shelf, Mag Vertical Drawer Shelf, Mag Vertical Nagra Shelf, Mag Vertical Utility Tray

## Mag Vertical Handle

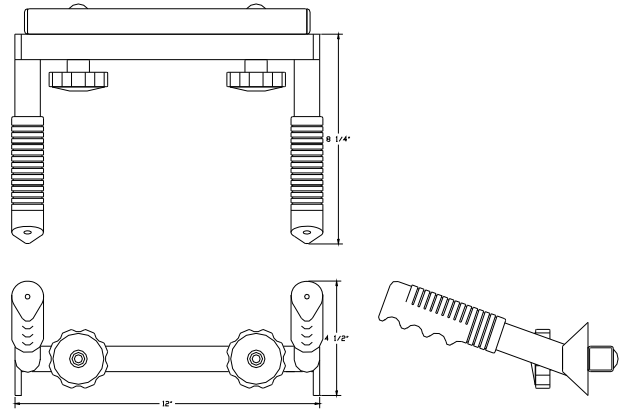

**Part No:** MAG-01 VH  
**Sale price:** \$ 151.00  
**Material:** Steel  
**Color:** Black  
**Max. Capacity:** 50 lbs.  
**Weight:** 3 lbs.  
**Dimensions:** D9 3/8" x W12" x H4 1/2"

**Shipping Weight/Dims:** 3 lbs. (L13" x W11" x H4")



**Requirements:** Mag Vertical Cart

**Conflicts:** None

**Suggestions:** Mag Vertical Shelves, Mag Vertical Sliding Shelf, Mag Vertical Nagra Shelf, Mag Vertical Utility Tray



## Mag Vertical Shelf



Mag Vertical Shelf's height location is fully adjustable. Shelf is easily removed for compact transportation by loosening two prongs. Shelf can be installed in front or rear of cart. Shelf is outfitted with carpet and trim around the edges.

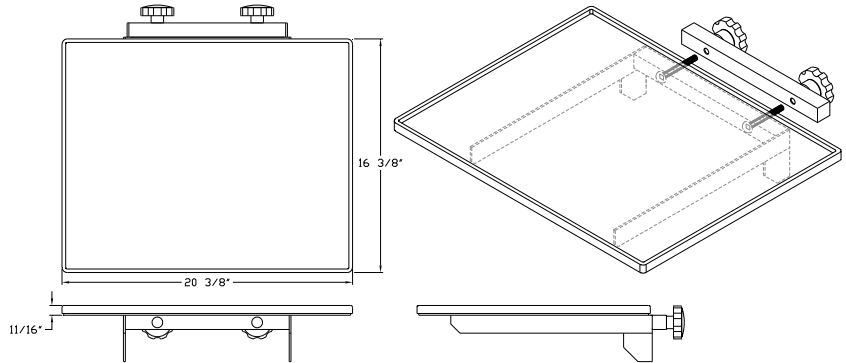

**Part No:** MAG-01 VS

**Sale price:** \$235.00

**Material:** Aluminum

**Color:** Black

**Max. Capacity:** 75 lbs.

**Weight:** 10 lbs.

**Dimensions:** D18 3/4" x W20 3/8" x H3 15/16"  
(ID D15 3/4" x W19 3/4" x H1/2")

**Requirements:** Mag Vertical Cart

**Conflicts:** None

**Suggestions:** Mag Vertical 5" Wheel Conversion Kit, Mag Vertical Legs with 8" Pneumatic Caster with Brakes, Mag Vertical Nagra Shelf, Mag Vertical Drawer Shelf, Mag Vertical Utility Tray

**Shipping Weight/Dims:** 11 lbs. (L20" x W20" x H5")



# Mag Vertical Drawer Shelf

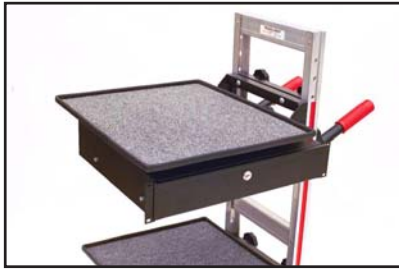

Mag Vertical Drawer Shelf with optional 2-space Drawer.



Mag Vertical Drawer Shelf's height location is fully adjustable. Drawer Shelf is easily removed for compact transportation by loosening two prongs. Drawer Shelf can be installed in front or rear of cart.

**Note: When ordering, please specify which side drawer opening should face. (Left, right or front)**

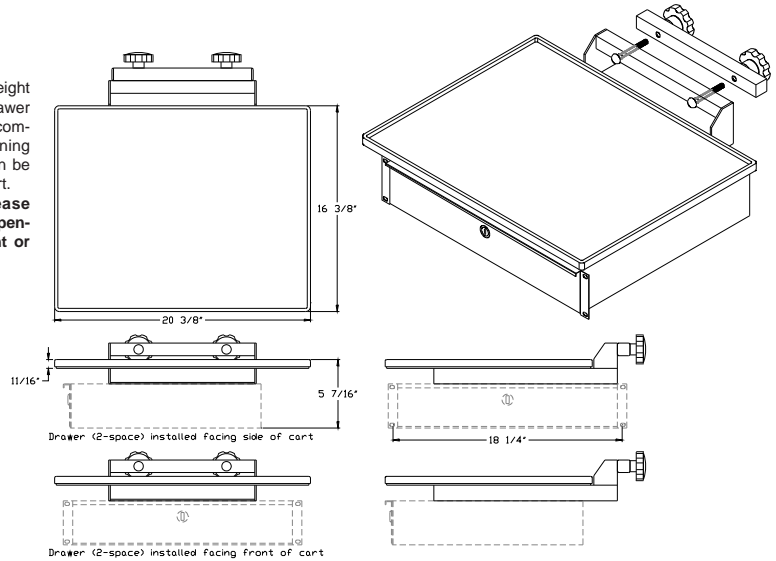

Part No: MAG-01 VSD  
 Sale price: \$255.00  
 Material: Aluminum  
 Color: Black  
 Weight: 10 lbs.  
 Max. Capacity: 75 lbs.  
 Dimensions: D21" x W19 1/8" x H3 1/8"  
 Note: Drawer not included, see page 107

Shipping Weight/Dims: 12 lbs. (L20" x W20" x H5")



Shipping Weight/Dims with 2-space Drawer: 26 lbs. (L20" x W20" x H9")  
 Shipping Weight/Dims with 3-space Drawer: 28 lbs. (L20" x W20" x H9")  
 Shipping Weight/Dims with 4-space Drawer: 30 lbs. (L20" x W20" x H11")

Requirements: Mag Vertical Cart, Mag Roller Sliding Drawer with Key (2-Space, 3-Space or 4-Space)  
 Conflicts: None  
 Suggestions: Mag Vertical 8" Wheel Conversion Kit, Mag Vertical Utility Tray, Mag Vertical Shelf, Mag Vertical Keyboard Shelf with Mouse Pad, Mag Vertical Utility Tray

## Mag Vertical Nagra Shelf



Mag Vertical Nagra Shelf's height location is fully adjustable. Nagra Shelf is easily removed for compact transportation by loosening two prongs. Nagra Shelf can be installed in front or rear of cart. Shelf is outfitted with carpet and trim around the edges.

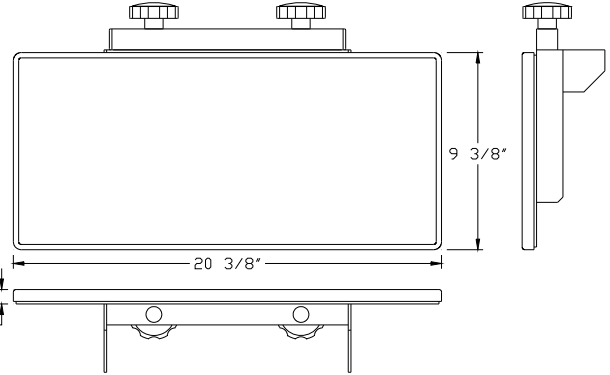
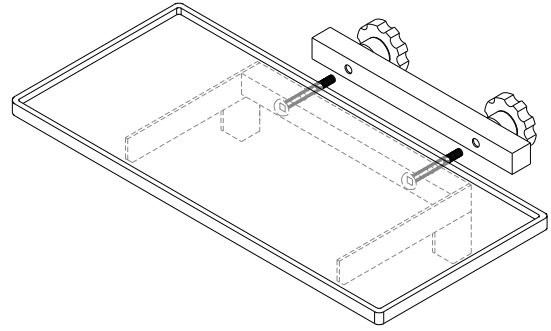

**Part No:** MAG-01 VSN

**Sale price:** \$205.00

**Material:** Aluminum

**Color:** Black

**Max. Capacity:** 75 lbs.

**Weight:** 7 lbs.

**Dimensions:** D11 3/4" x W20 3/8" x H3 15/16"  
(ID D8 3/4" x W19 3/4" x H1/2")

**Shipping Weight/Dims:** 8 lbs. (L21" x W13" x H7")



**Requirements:** Mag Vertical Cart

**Conflicts:** None

**Suggestions:** Mag Vertical Shelf, Mag Vertical 5/8" Baby Pin with Cable Hooks, Mag Umbrella Holder, Mag Umbrella, Mag Vertical Utility Tray, Mag Vertical Sliding Shelf, Mag Vertical Drawer Shelf

# Mag Vertical Sliding Shelf

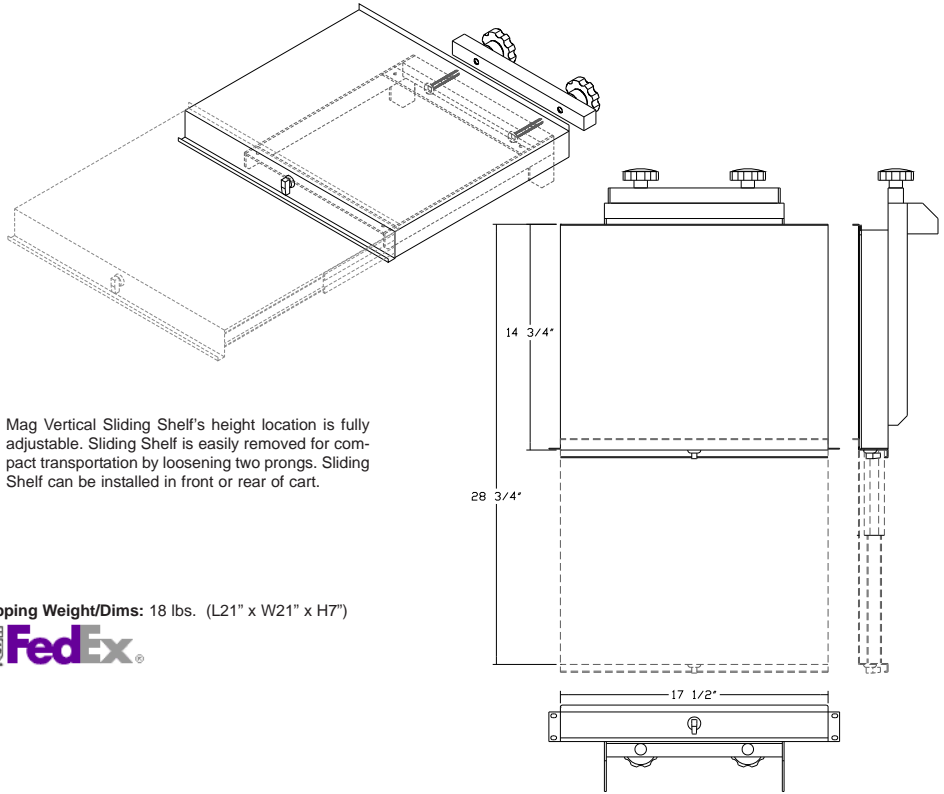

Mag Vertical Sliding Shelf's height location is fully adjustable. Sliding Shelf is easily removed for compact transportation by loosening two prongs. Sliding Shelf can be installed in front or rear of cart.

**Part No:** MAG-01 VSS  
**Sale price:** \$370.00  
**Material:** Steel  
**Color:** Black  
**Max. Capacity:** 50 lbs.  
**Weight:** 17 lbs.  
**Dimensions:** D19" x W19" x H5 5/8"

**Shipping Weight/Dims:** 18 lbs. (L21" x W21" x H7")



**Requirements:** Mag Vertical Cart  
**Conflicts:** None  
**Suggestions:** Mag Vertical Shelf, Mag Vertical Keyboard Shelf with Mouse Pad, Mag Utility Tray with Cup Holder, Mag Vertical Drawer Shelf, Mag Vertical Nagra Shelf, Mag Vertical Keyboard Shelf

## Mag Vertical Keyboard Shelf with Mouse Pad



Mag Vertical Keyboard Shelf's height location is fully adjustable. Keyboard Shelf is easily removed for compact transportation by loosening two prongs. Keyboard Shelf can be installed in front or rear of cart. Keyboard locks in place when fully extended. Mouse pad base will slide and lock to left or right side of unit, mouse pad base hides underneath Keyboard when not in use.

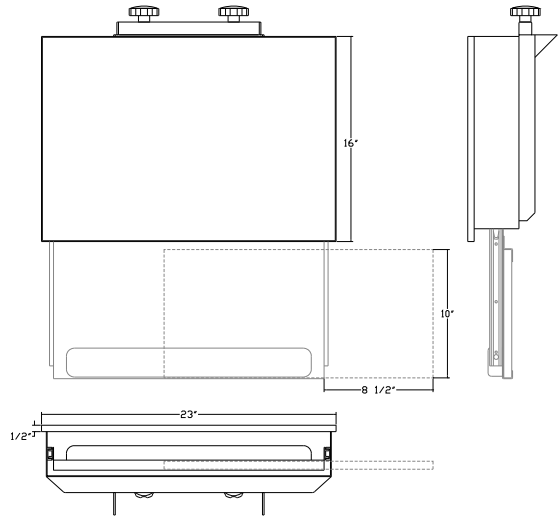

**Part No:** MAG-01 VKB

**Sale price:** \$ 675.00

**Material:** Steel

**Color:** Black

**Max. Capacity:** 75 lbs.

**Weight:** 36 lbs.

**Dimensions:** D19 1/2" x W23 3/8" x H7 1/8"

**Shipping Weight/Dims:** 39 lbs. (L25" x W19" x H9")



**Requirements:** Mag Vertical Cart

**Conflicts:** None

**Suggestions:** Mag Vertical Sliding Shelf, Mag Vertical Drawer Shelf, Mag Vertical Shelf, Mag Nagra Shelf, Mag Vertical Utility Tray



# Mag Vertical Utility Tray

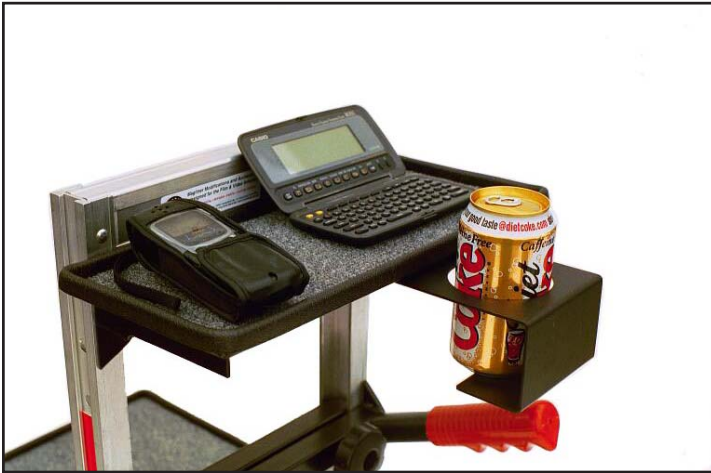

Mag Vertical Utility Tray's height location is fully adjustable. Utility Tray is easily removed for compact transportation by loosening two prongs. Utility Tray can be installed in front or rear of cart. Unit has a built in Cup Holder which hides underneath Utility Tray when not in use. Utility Tray is outfitted with carpet and trim around the edges.

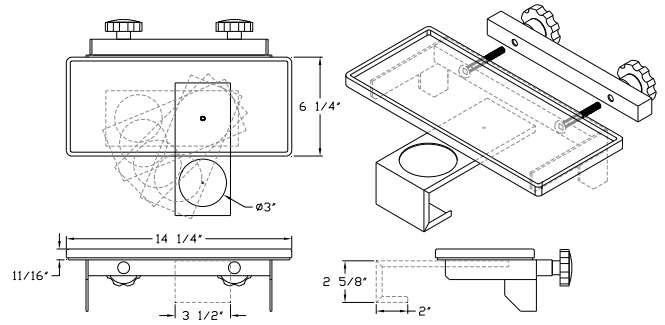

**Part No:** MAG-01 VSU  
**Sale price:** \$ 190.00  
**Material:** Steel  
**Color:** Black  
**Max. Capacity:** 50 lbs.  
**Weight:** 5 lbs.  
**Dimensions:** D8 7/8" x W14 3/8" x H3 1/4"  
 (ID D5 5/8" x W13 5/8" x H 1/2")

**Shipping Weight/Dims:** 6 lbs. (L16" x W11" x H6")



**Requirements:** Mag Vertical Cart  
**Conflicts:** None  
**Suggestions:** Mag Vertical Shelf, Mag Vertical Drawer Shelf, Mag Vertical Sliding Shelf, Mag Vertical Nagra Shelf



## Mag Vertical Triple 5/8" Baby Pin Bracket

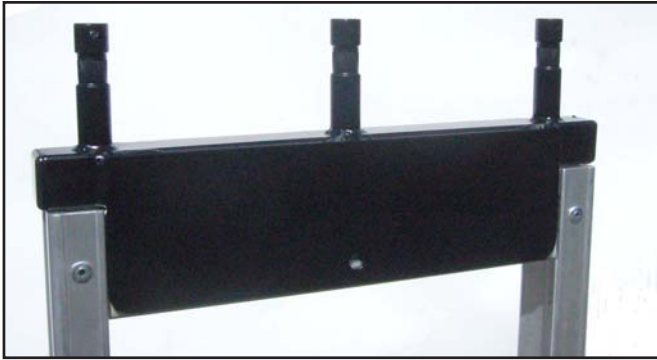

Mag Vertical Triple 5/8" Baby Pin will hold multiple accessories with a 5/8" receiver, such as a Mag Video Monitor Bracket, Mag Video Offset Bracket and Mag Umbrella Holder.

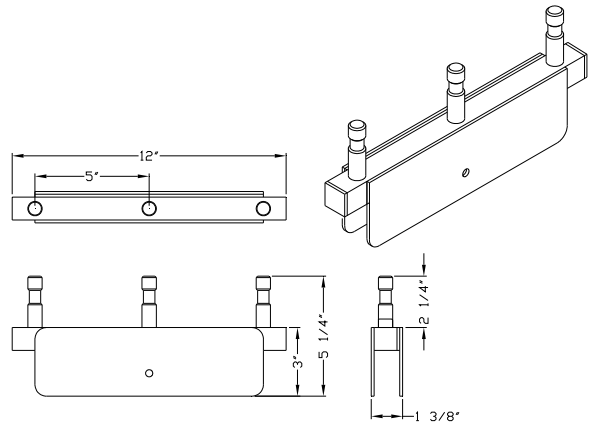

**Part No:** MAG-01 VPP  
**Sale price:** \$225.00  
**Material:** Steel  
**Color:** Black  
**Max. Capacity:** 40 lbs.  
**Weight:** 4 lbs.  
**Dimensions:** D1 3/8" x W12" x H5 1/4"

**Shipping Weight/Dims:** 5 lbs. (L13" x W10" x H5")



**Requirements:** Mag Vertical Cart

**Conflicts:** None

**Suggestions:** Mag Offset Arm, Mag Swing Arm, Mag Umbrella Holder, Mag Vertical Shelf, Mag Vertical Nagra Shelf, Mag Vertical Utility Tray, Mag Vertical Sliding Shelf

## Mag Vertical 5/8" Baby Pin

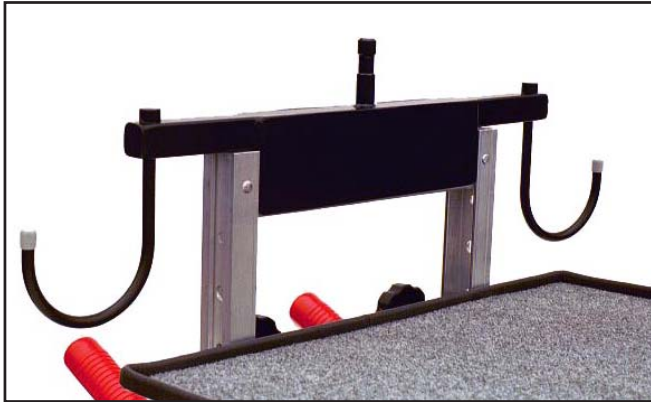

Mag Vertical 5/8" Baby Pin will hold any accessory with a 5/8" receiver, such as a Mag Video Monitor Bracket, Mag 9" Monitor Tray or Mag Umbrella Holder. Unit has two 6" rotating cable holders.

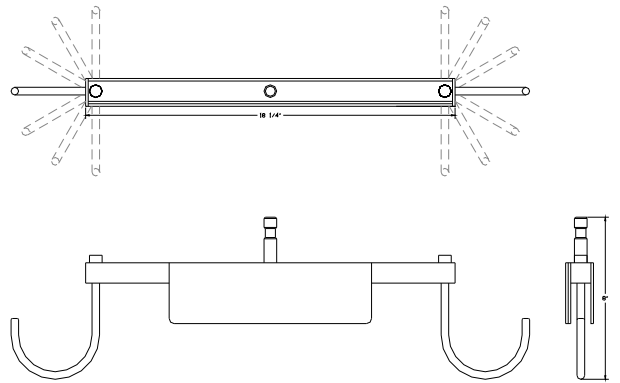

**Part No:** MAG-01 VP  
**Sale price:** \$ 195.00  
**Material:** Steel  
**Color:** Black  
**Max. Capacity:** 40 lbs.  
**Weight:** 5 lbs.  
**Dimensions:** D1 3/8" x W25 1/2" x H8"

**Shipping Weight/Dims:** 6 lbs. (L21" x W7" x H7")



**Requirements:** Mag Vertical Cart  
**Conflicts:** None  
**Suggestions:** Mag Umbrella Holder, Mag Vertical Shelf, Mag Vertical Nagra Shelf, Mag Vertical Utility Tray



Mag Umbrella with Mag Umbrella Holder attached to Mag Vertical 5/8" Baby Pin



## Mag Vertical "Snap-On" 5/8" Baby Pin (Side)



The Mag Vertical Side Pin attaches to any point within the Magliner frame. Secures with two 5/16-18 set screws using a hex wrench. May be used on either side of cart.

**Part No:** MAG-01 VP SD

**Sale price:** \$81.00

**Material:** Steel

**Color:** Black

**Max. Capacity:** 81 lbs.

**Weight:** 2 lbs.

**Dimensions:** L5" x W2" x H4 5/16"

**Shipping Weight/Dims:** 2 lbs. (L9" x W5" x H3")

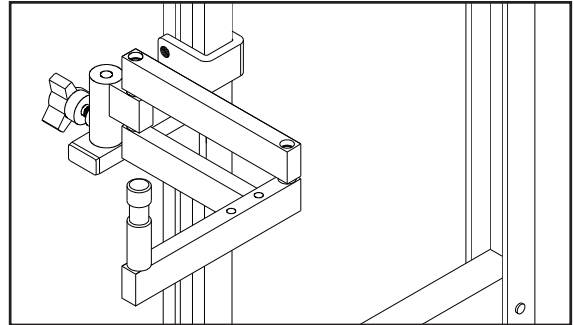
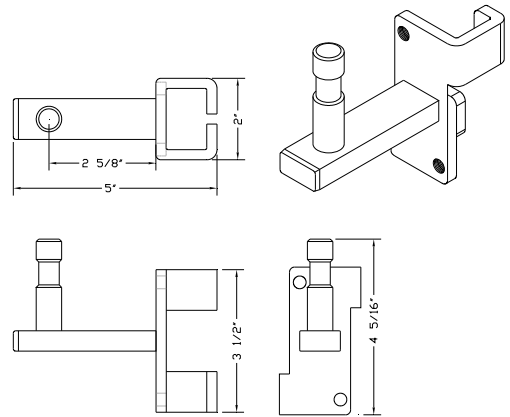

Mag Swing Arm (Small) attached to Mag Vertical Side Pin

**Requirements:** Mag Vertical Cart

**Conflicts:** None

**Suggestions:** Mag Swing Arm, Mag Lap Top Tray, Mag Offset Arm, Mag Umbrella Holder

## Mag Flat Screen Vertical Dual Riser (Adj.) with 5/8" Baby Pin



Mag Vertical Dual Riser shown with two 17" flat Monitors. Riser can be adjusted up to 16"

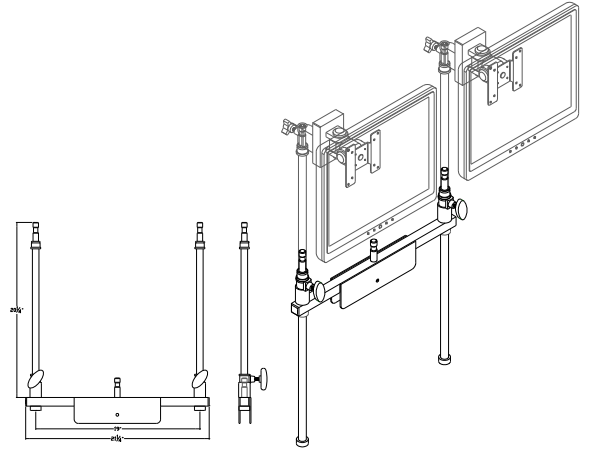

**Part No:** MAG-01 VPR  
**Sale price:** \$ 325.00  
**Material:** Steel, Aluminum  
**Color:** Black  
**Max. Capacity:** 75 lbs.  
**Weight:** 7 lbs.  
**Dimensions:** L1 5/16" x W23 1/4" x H23 1/4"

**Shipping Weight/Dims:** 7 lbs. (L5" x W5" x H25")



See page 122 for Mag LCD Tilt Head (3-24 lbs.) and Mag LCD 4" Pin adapter



**Requirements:** Mag Vertical Cart  
**Conflicts:** None  
**Suggestions:** Mag LCD Tilt Head, Mag LCD 4"/6"/8" Tilt Head Adapter, Mag Umbrella Holder, Mag Vertical Shelf

## Mag Antenna Base (Telescopic) & Antenna Riser

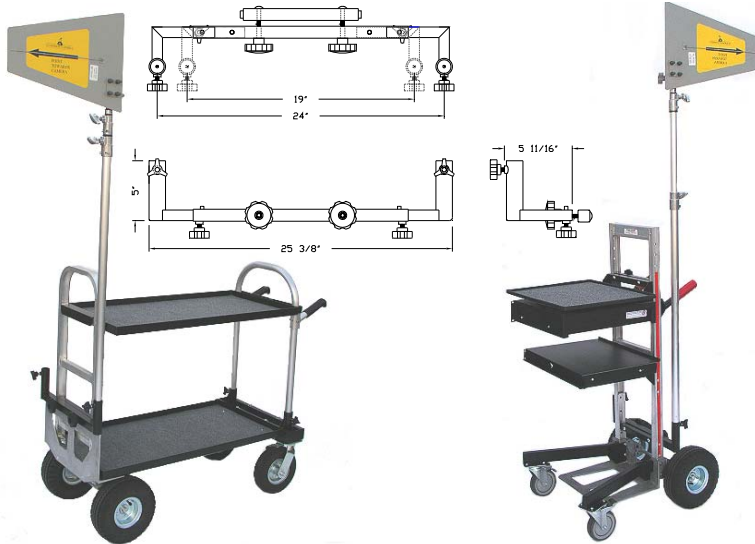

Mag Junior shown with Mag Antenna Base and single Antenna Riser

**Part No:** MAG-A NX, MAG-A VX (Vertical)  
**Sale price:** \$ 250.00  
**Material:** Steel  
**Color:** Black  
**Max. Capacity:** 40 lbs.  
**Weight:** 4 lbs.  
**Dimensions:** D7" x W20 3/8" - 25 3/8" x H6 1/2"

**Shipping Weight/Dims:** 6 lbs. (L23" x W11" x H5")



**Requirements:** Mag Nose (Heavy Duty)  
**Conflicts:** Mag Grip/Light Caddy, Mag Nose Loading Handles, Mag Nose Shelf, Mag Nose Nagra Shelf  
**Suggestions:** Mag Antenna Riser (2) per Base

Mag Junior Vertical shown with Mag Antenna Base and single Antenna Riser

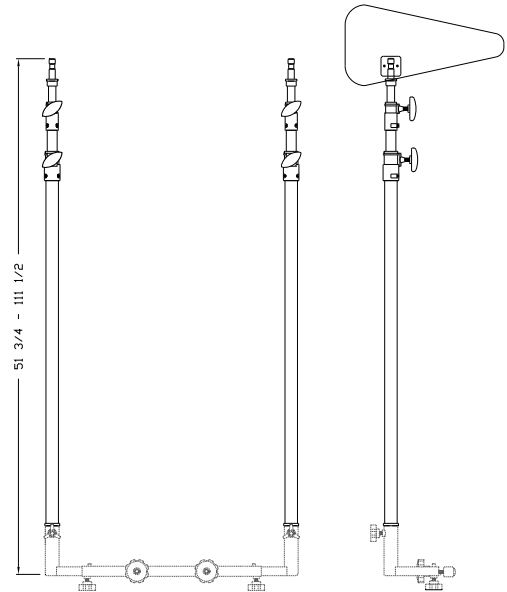

**Shipping Weight/Dims:** 6 lbs. (L5" x W5" x H49")



**Part No:** MAG-A RX  
**Sale price:** \$ 355.00  
**Material:** Aluminum/Steel  
**Color:** Alum. & Chrome  
**Max. Capacity:** 100 lbs.  
**Weight:** 5 lbs.  
**Dimensions:** D3 1/2" x W2" x H48 3/4" - H113 1/2"

**Requirements:** Mag Antenna Base  
**Conflicts:** Mag Umbrella, Mag HD Tent, Mag Rain Tent  
**Suggestions:** Mag 3" Cable Holder, Mag 6" Cable Holder, Mag Vertical Drawer Shelf

1 NO.	PART
1	BS SB Main Plate
2	BS Socket Block
4	Doughty Clamp Complete.SLDPRT
	HFBOLT 0.5-13x3x1.25-S
5	FORE AND
7	Central
8	SIDE TO
10	Pro Pin
11	

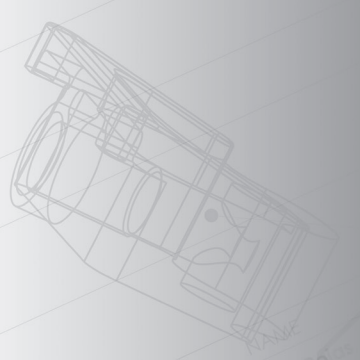

OTHERWISE SPECIFIED:  
 DIMENSIONS x,xxxx ARE IN INCHES  
 DIMENSIONS (x.xx) ARE MILLIMETERS  
 FRACTIONAL:  
 ANGULAR: MACH± BEND ±  
 TWO PLACE DECIMAL  
 THREE PLACE DECIMAL

DRAWN	Manolo Po
CHECKED	Carly G
MFG APPR.	
MATERIAL	
FINISH	

USED ON  
 Steadicam Garfield  
**DO NOT SCALE DRAWING**

**PROPRIETARY AND CONFIDENTIAL**  
 THE INFORMATION CONTAINED IN THIS  
 DRAWING IS THE PROPERTY OF  
**BACKSTAGE EQUIPMENT, INC.**  
 NO REPRODUCTION IN PART OR WHOLE  
 WITHOUT THE WRITTEN PERMISSION  
 OF BACKSTAGE EQUIPMENT, INC IS

**Backstage Equipment, Inc. • 8052 Lankershim Bl. • North Hollywood, CA 91605 • USA**  
**(800) 692-2787 • Fax (818) 504-6180 • www.backstageweb.com • E-Mail info@backstageweb.com**