



Backstage Catalog '23

2nd edition



Index

Terms and Conditions	90
Carts (Grip & Lighting)	
4 x 4 Coaster Junior Cart	56
4 x 4 Coaster Senior Cart	52
4 x 4 Coaster Senior Cart Plus	53
4 x 4 Grande Cart	51
4 x 4 Mini Cart	13
4 x 4 Mini Cart Plus	14
Apple Box Cart Cart	30
Baby Stand Cart	29
Baby Stand Mini Cart	16
Blackbird Stand Cart (American)	72
Cable Distro Cart	39
Cable Distro Mini Cart	4
Cable/Sand Bag Cart	36
Cable/Sand Bag Cart (Foldable)	37
Cable/Sand Bag Mini Cart	5
Cable/Sand Bag Mini Cart (Foldable)	6
Cable Cross-Over Cart	42
Combo Stand Cart	28
Combo Stand Mini Cart	15
C-Stand Cart	43
C-Stand Plus Cart	44
C-Stand Mini Cart	8
C-Stand Mini Cart (Modular)	9-10
C-Stand/Hi-Roller Utility Cart	47
C-Stand/Hi-Roller Utility Cart Plus	48
C-Stand Self Stabilizing Magliner Carts	45-46
Electric Cart	23
Electric Mini Cart	2
EZ-Load Cart	57
Grip Junior Cart	56
Grip Senior Cart	55
Head Cart	31
Head Cart Mini Cart	7
Head Cart Plus Cart	32
HMI Cart	33
HMI Mini Cart	18
Kino-Flo Mini Cart	3
Long John Silver Stand Carts (Avenger)	69-70
Muscle Cart	38
SkyPanel 60 Mini Cart	11-12
SkyPanel 120 Cart	26-27
SkyPanel 360 Cart (Dual)	26
SkyPanel 360 Cart (Single)	27
Speed Rail Cart	50
Stinger Cart	41
Stratto Safe B-150 Stand Cart UK (Avenger)	71
Stratto Safe B-150P Stand Cart (Avenger)	70
Super Duz-All Cart	49
Super Duz-All Mini Cart	17
Universal Junior Cart	34
Universal Senior Cart	35
Utility Plywood/Track Cart	58
Whip Distro Cart	40

Carts (Prop & Craft Service)

Prop-Chair Cart	65
-----------------------	----

Carts (Set Box)

Ditty Cart Cart	59
4-Crate Set Box Horizontal Mini Cart	19
4-Crate Set Box Vertical Cart	60
6-Crate Set Box Vertical Cart	61
6-Crate Set Box Horizontal Mini Cart	20
7-Crate Set Box Cart	62
7-Crate Set Box Mini Cart	21
8-Crate Set Box Cart	64
9-Crate Set Box Cart	63
9-Crate Set Box Mini Cart	22

Carts (Misc.)

Big Wheels	75
Generator Armor Carts	76-77
ARRIMAX Lamp Dolly	74
Shot Bag Cart	67

Camera, Sound, DIT, Video & Steadi-Cam Carts

Camera Case Carts (TR-04, TR-04 JR)	79-83
Monitor Mover Cart	66
Steady-Cam Case Cart (TR-05 EL)	84
Transformer Carts (TR-01 8, TR-08 EFX)	85-88

Grip & Electric Cart Equipment

Gel Holders	78
Milk Crates	78
Milk Crate Liners	78
Net Baskets	78

* New products listed in bold type



Electric Mini Cart

Part No. E-01 MINI

Sale Price: \$ 2,375.00

Material: Steel

Color: Black Hammertone

Max. Capacity: 1,000 lbs. / 454 kgs.

Weight: 163 lbs. / 74 kgs.

Dimensions: L48" x W21 1/4" x H51 1/2"
L122cm x W54cm x H131cm

Features:

- Holds up to 24 Baby Stands or 18 Combo Stands with optional Stand Holders
- 3 Sliding Milk Crate Compartments
- Top Tray (D19 1/4" x W13 5/8" x H1 1/2" / D48.9cm x W34.6cm x H3.8cm)
- Jockey Box Holds (1) Half Milk Crate
- End Pans (D19 1/4" x W13 3/16" / D48.9cm x W33.5cm)
- Wheels: (2) 10" Swivel Casters & (2) 10" Rigid Casters
- Foot Brake

Accessories:

- Baby Stand Holder (Holds 4 Stands) (**MINI ES-4**) \$ 60.00
- Combo Stand Holder (Holds 3 Stands) (**MINI CS-3**) \$ 60.00

Options:

- Milk Crate (**B-03**) \$ 20.00
- Half Milk Crate (**B-05**) \$ 20.00
- Full Milk Crate Liner (**B-04**) \$ 19.50
- Half Milk Crate Liner (**B-06**) \$ 19.00
- Foam Filled Tires (**WA-10 FOAM CTR**) \$ 240.00

Replacement parts:

- 10" Pneumatic Tire (**WA-10 TIRE**) \$ 24.00
- 10" Pneumatic Tube (**WA-10 TUBE**) \$ 12.00
- 10" Pneumatic Rigid Caster Wheel (**W-10 RCX**) \$ 88.00
- 10" Pneumatic Swivel Caster Wheel (**W-10 SCX**) \$ 91.00

Shipping Dimensions: L49" x W22" x H57" (213 lbs.)
L125cm x W56cm x H145cm (97 kgs.)



NOTE: Milk Crates not included

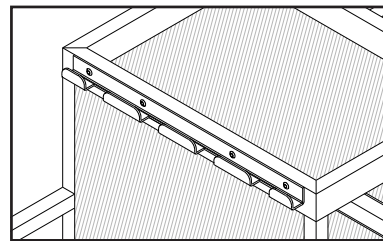

Electric Stand Holder accessory mounted on cart.

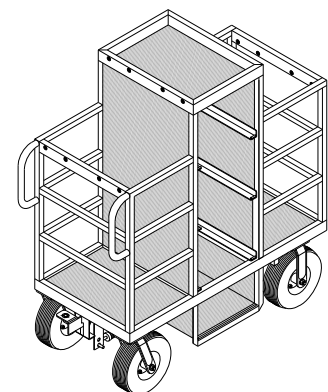

Rear view image of E-01 MINI Cart

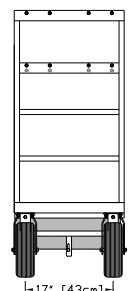
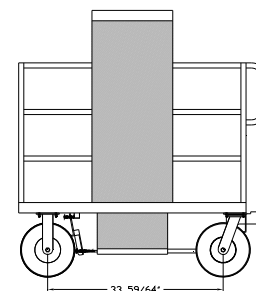
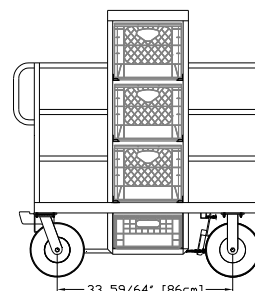
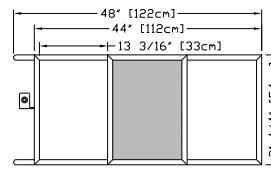
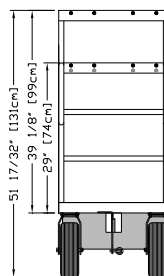



Kino-Flo Mini Cart

Part No. E-09 MINI

Sale Price: \$ 2,375.00

Material: Steel

Color: Black Hammertone

Max. Capacity: 1,000 lbs. / 454 kgs.

Weight: 173 lbs. / 79 kgs.

Dimensions: L48" x W21 1/4" x H51 1/2"
L122cm x W54cm x H131cm

Features:

- Holds up to (12) 4 Foot 4-Bank Kinoflo Fixtures
- Holds up to (12) Baby or 9 Combo Stands with optional Stand Holders
- 3 Sliding Milk Crate Compartments
- Top Tray (D19 1/4" x W13 5/8" x H1 1/2" / D48.9cm x W34.6cm x H3.8cm)
- Jockey Box Holds (1) Half Milk Crate
- End Pan (D19 1/4" x W27 3/8" / D48.9cm x W69.5cm)
- Wheels: (2) 10" Swivel Casters & (2) 10" Rigid Casters
- Foot Brake

Accessories:

- Baby Stand Holder (Holds 4 Stands) **(MINI ES-4)** \$ 60.00
- Combo Stand Holder (Holds 3 Stands) **(MINI CS-3)** \$ 60.00

Options:

- Milk Crate **(B-03)** \$ 20.00
- Half Milk Crate **(B-05)** \$ 20.00
- Full Milk Crate Liner **(B-04)** \$ 19.50
- Half Milk Crate Liner **(B-06)** \$ 19.00
- Foam Filled Tires **(WA-10 FOAM CTR)** \$ 240.00

Replacement parts:

- 10" Pneumatic Tire **(WA-10 TIRE)** \$ 24.00
- 10" Pneumatic Tube **(WA-10 TUBE)** \$ 12.00
- 10" Pneumatic Rigid Caster Wheel **(W-10 RCX)** \$ 88.00
- 10" Pneumatic Swivel Caster Wheel **(W-10 SCX)** \$ 91.00

Shipping Dimensions: L49" x W22" x H57" (223 lbs.)
L125cm x W56cm x H145cm (101 kgs.)



NOTE: Milk Crates not included

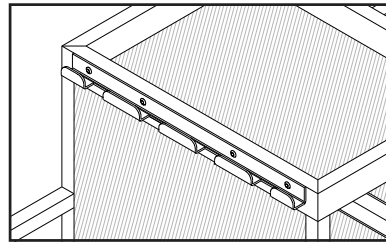

Electric Stand Holder accessory mounted on cart.

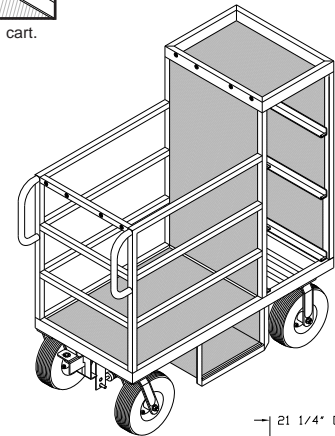

Rear view image of E-09 MINI Cart

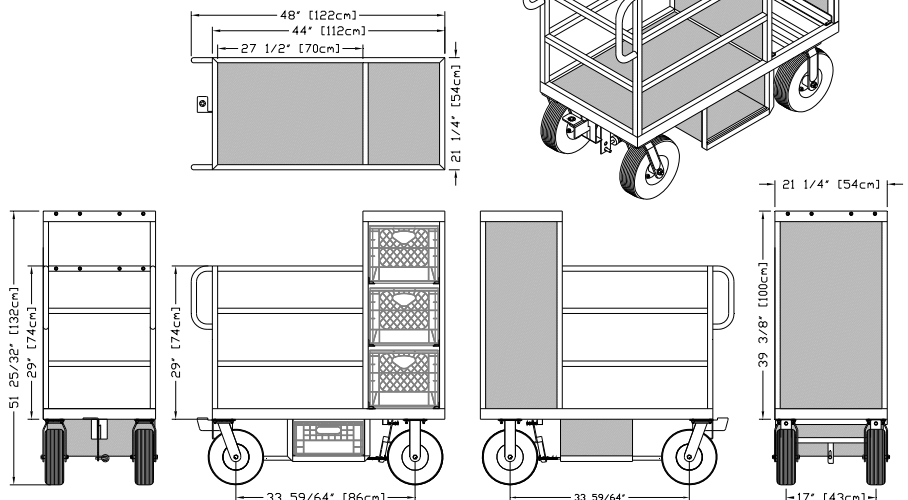



Cable Distro Mini Cart

Part No. GE-03 MINI

Sale Price: \$ 1,890.00

Material: Steel

Color: Black Hammertone

Max. Capacity: 1,000 lbs. / 454 kgs.

Weight: 151 lbs. / 69 kgs.

Dimensions: L48" x W21 1/4" x H44 1/2"
L122cm x W54cm x H113cm

Features:

- Holds Milk Crates, Cable, Sand Bags, Ballasts
- (2) Stationary Shelves (D20 7/8" x W40" / D53cm x W101.6cm)
- Jockey Box Holds (1) Half Milk Crate
- Wheels: (2) 10" Swivel Casters & (2) 10" Rigid Casters
- Foot Brake

Accessories:

Options:

- Milk Crate **(B-03)** \$ 20.00
- Half Milk Crate **(B-05)** \$ 20.00
- Full Milk Crate Liner **(B-04)** \$ 19.50
- Half Milk Crate Liner **(B-06)** \$ 19.00
- Foam Filled Tires **(WA-10 FOAM CTR)** \$ 240.00

Replacement parts:

- 10" Pneumatic Tire **(WA-10 TIRE)** \$ 24.00
- 10" Pneumatic Tube **(WA-10 TUBE)** \$ 12.00
- 10" Pneumatic Rigid Caster Wheel **(W-10 RCX)** \$ 88.00
- 10" Pneumatic Swivel Caster Wheel **(W-10 SCX)** \$ 91.00

Shipping Dimensions: L49" x W22" x H50" (201 lbs.)
L125cm x W56cm x H127cm (91 kgs.)



NOTE: Milk Crates not included



Rear view image of GE-03 MINI Cart

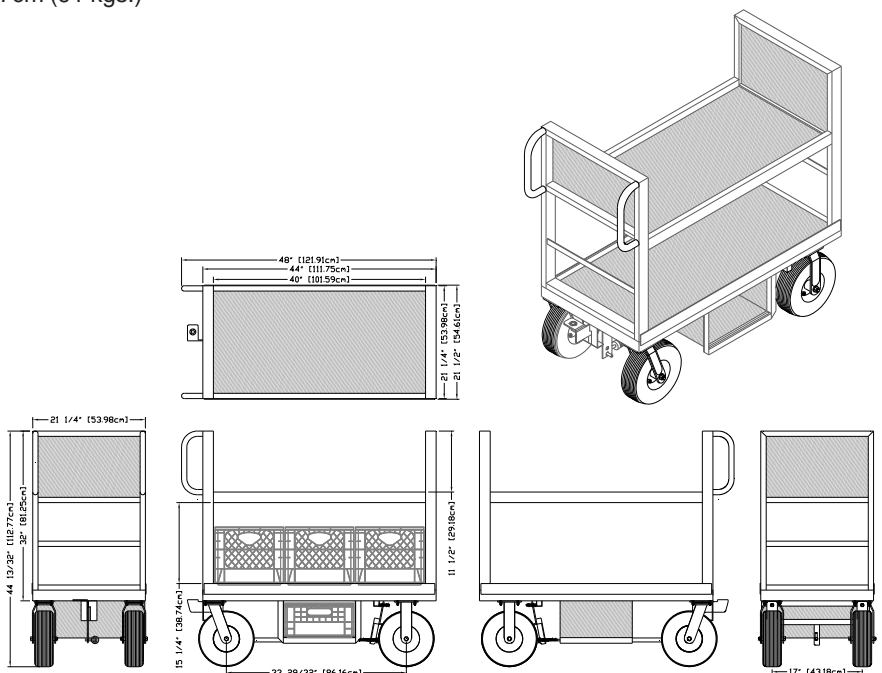



Cable/Sand Bag Mini Cart

Part No. GE-02 MINI

Sale Price: \$ 1,225.00

Material: Steel

Color: Black Hammertone

Max. Capacity: 1,000 lbs. / 454 kgs.

Weight: 82 lbs. / 37.3 kgs.

Dimensions: L41 1/8" x W24 5/8" x H43 1/4"
L122cm x W54cm x H115cm

Features:

- Holds Cable and Sandbags
- Carriage Base (D19 1/2" x W16" / D49.5cm x W40.6cm)
- (4) 10" Pneumatic Offset Wheels
- Hand Brake

Accessories:

Options:

- Foam Filled Tires (**WA-10 FOAM OS**) \$ 240.00

Replacement parts:

- 10" Pneumatic Tire (**WA-10 TIRE**) \$ 24.00
- 10" Pneumatic Tube (**WA-10 TUBE**) \$ 12.00
- 10" Pneumatic Offset Wheel (**W-10 OS34X**) \$ 65.00
- 3/4" Sealed Bearing (**WA-34 BR**) \$ 2.75 (Need (2) per Wheel)

Shipping Dimensions: L50" x W25" x H33" (122 lbs.)
L127cm x W63.5cm x H83.8cm (55.5 kgs.)



Rear view image of GE-02 MINI Cart

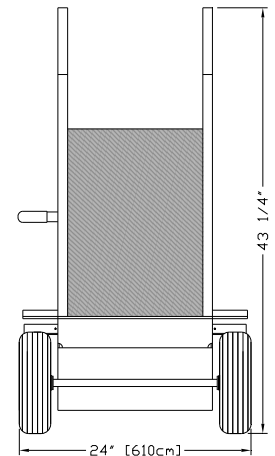
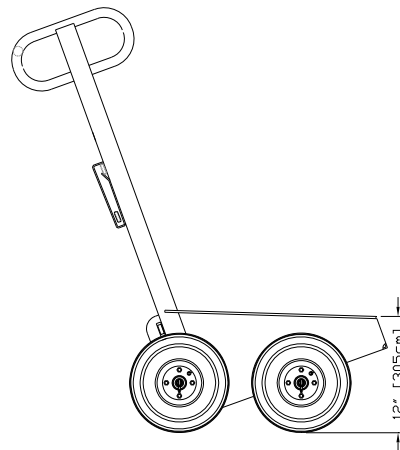
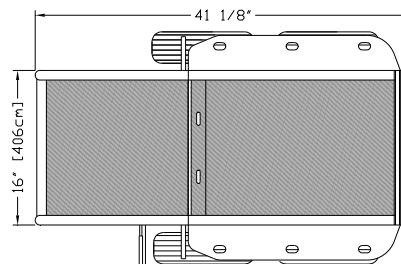



Cable/Sand Bag Mini Cart (Foldable)

Part No. GE-02 MINI FD

Sale Price: \$ 1,600.00

Material: Steel

Color: Black Hammertone

Max. Capacity: 1,000 lbs. / 454 kgs.

Weight: 98 lbs. / 44.6 kgs.

Dimensions: L39 1/2" x W24 1/2" x H43 1/2"

L100cm x W62cm x H110cm

L34 1/2" x W24 1/2" x H20 1/4" (Folded)

L88cm x W62cm x H51cm (Folded)

Features:

- Folds to a compact size (Folding mechanism uses Quick Release Aircraft Pins to lock system into place)
- Holds Cable and Sandbags
- Carriage Base (D18 1/2" x W16" / D47cm x W40.6cm)
- (4) 10" Pneumatic Offset Wheels
- Hand Brake

Accessories:

Options:

- Foam Filled Tires (**WA-10 FOAM OS**) \$ 240.00

Replacement parts:

- 10" Pneumatic Tire (**WA-10 TIRE**) \$ 24.00
- 10" Pneumatic Tube (**WA-10 TUBE**) \$ 12.00
- 10" Pneumatic Offset Wheel (**W-10 OS34X**) \$ 65.00
- 3/4" Sealed Bearing (**WA-34 BR**) \$ 2.75 (Need (2) per Wheel)

Shipping Dimensions: L26" x W22" x H36" (115 lbs.)

L65cm x W55cm x H91.4cm (52 kgs.)

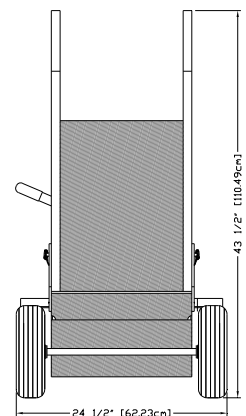
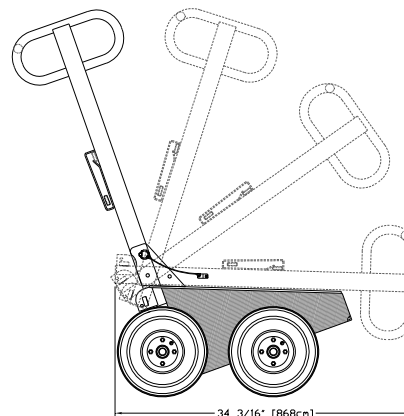
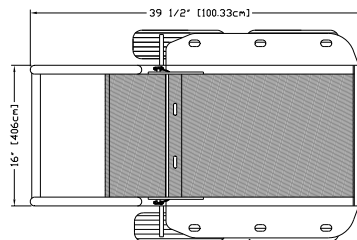



Head Mini Cart

Part No. E-02 MINI

Sale Price: \$ 2,495.00

Material: Steel / Aluminum

Color: Black Hammertone

Max. Capacity: 1,000 lbs. / 454 kgs.

Weight: 155 lbs. / 70.5 kgs.

Dimensions: L48" x W21 1/4" x H59 3/8"
L122cm x W54cm x H151cm

Features:

- Holds up to 16 Electric Stands or 12 Combo Stands with optional Stand Holders
- 3 Shelves (L42" x W21 1/4" / 107cm x W54cm) 1 Stationary, 2 Adjustable (Aluminum)
- Jockey Box Holds (1) Half Milk Crate
- Wheels: (2) 10" Swivel Casters & (2) 10" Rigid Casters
- Foot Brake

Accessories:

- Baby Stand Holder (Holds 4 Stands) (**MINI ES-4**) \$ 65.00
- Combo Stand Holder (Holds 3 Stands) (**MINI CS-3**) \$ 65.00
- Rear Baby/Combo Stand Holder Bracket (**MINI HOLDER-8**) \$ 105.00
- Additional Adjustable Shelf (**E-02 MINI SHELF**) \$ 430.00

Options:

- Milk Crate (**B-03**) \$ 20.00
- Half Milk Crate (**B-05**) \$ 20.00
- Full Milk Crate Liner (**B-04**) \$ 19.50
- Half Milk Crate Liner (**B-06**) \$ 19.00
- Foam Filled Tires (**WA-10 FOAM CTR**) \$ 240.00

Replacement parts:

- 10" Pneumatic Tire (**WA-10 TIRE**) \$ 24.00
- 10" Pneumatic Tube (**WA-10 TUBE**) \$ 12.00
- 10" Pneumatic Rigid Caster Wheel (**W-10 RCX**) \$ 88.00
- 10" Pneumatic Swivel Caster Wheel (**W-10 SCX**) \$ 91.00

Shipping Dimensions: L49" x W22" x H65" (218 lbs.)
L125cm x W56cm x H165cm (99 kgs.)



NOTE: Milk Crates not included

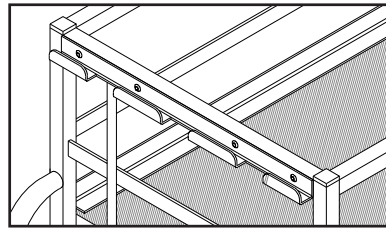

Electric Stand Holder accessory mounted on cart.

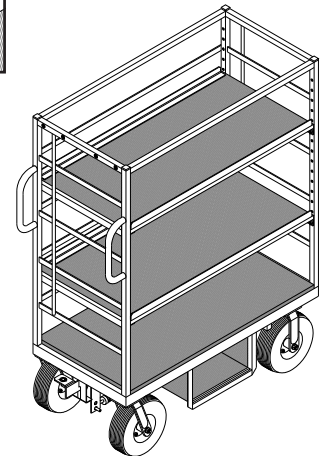

Rear view image of E-02 MINI Cart

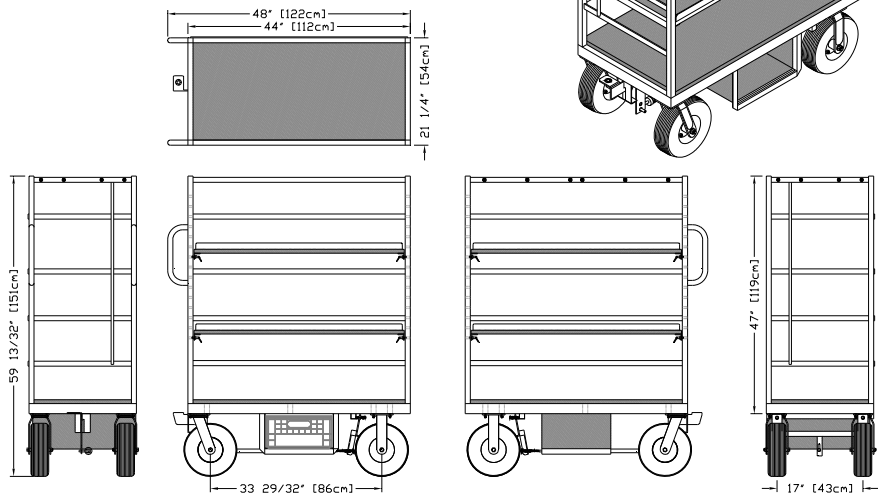



C-Stand Mini Cart

Part No. GE-13 MINI

Sale Price: \$ 2,372.00

Material: Steel

Color: Black Hammertone

Max. Capacity: 1,000 lbs. / 454 kgs.

Weight: 101 lbs. / 46 kgs.

Dimensions: L27 13/16" x W25" x H60 3/8"
L70.6cm x W63.5cm x H153.4cm

Features:

- Holds up to 13 C-Stands
- Holds (2) Milk Crates
- Holds (4) C-Stand Gobo Head and Arms
- Holds Sand Bags
- Wheels: (2) 10" Pneumatic Offset Wheels & (2) 8" Swivel Casters
- Hand Brake

Accessories:

Options:

- Milk Crate **(B-03)** \$ 20.00
- Full Milk Crate Liner **(B-04)** \$ 19.50
- Foam Filled Tires **(WA-10 FOAM OS and WA-08 FOAM CTR)** \$ 224.00

Replacement parts:

- 8" Pneumatic Tire **(WA-08 TIRE)** \$ 22.00
- 8" Pneumatic Tube **(WA-08 TUBE)** \$ 11.00
- 8" Pneumatic Swivel Caster Wheel **(W-08 SCX)** \$ 85.00
- 10" Pneumatic Tire **(WA-10 TIRE)** \$ 24.00
- 10" Pneumatic Tube **(WA-10 TUBE)** \$ 12.00
- 10" Pneumatic Offset Wheel **(W-10 OS34X)** \$ 65.00

Shipping Dimensions: L60" x W26" x H33" (151 lbs.)
L152.4cm x W66cm x H83.8cm (69 kgs.)



NOTE: Milk Crates not included



Rear view image of GE-13 MINI Cart

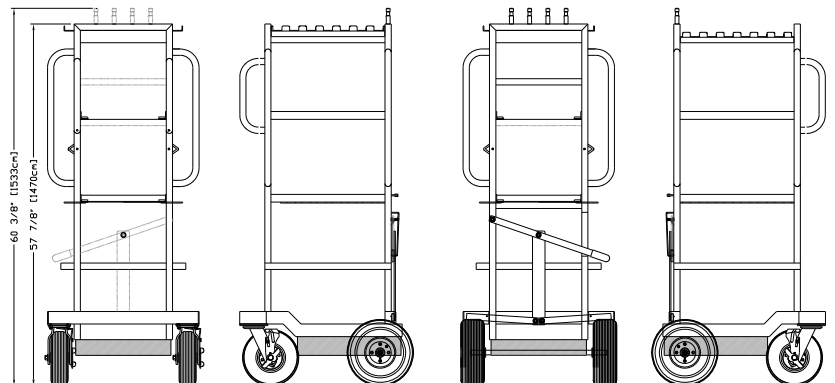
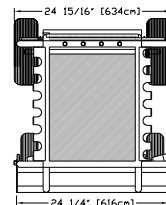



C-Stand Mini Cart (Modular)

Part No. GE-19 MINI

Sale Price: \$ 2,050.00

Material: Steel

Color: Black Hammertone

Max. Capacity: 1,000 lbs. / 454 kgs.

Weight: 99 lbs. / 45 kgs.

Dimensions: L27 13/16" x W25" x H60 3/8"
L70.6cm x W63.5cm x H153.4cm

Note: Cart does not include any of the optional stand holders or 5/8" Baby Pins shown, you must order these accessories separately depending on your needs.

Features:

- Holds up to 13 C-Stands or (8) Combo Stands or (11) Baby Stands or you may combine different Stand Holders depending on your needs
- Holds (2) Milk Crates
- Holds (4) C-Stand Gobo Head and Arms
- Holds Sand Bags
- Wheels: (2) 10" Pneumatic Offset Wheels & (2) 8" Swivel Casters
- Hand Brake

Accessories:

- C-Stand Holder Set Right Side (**GE-19 MINI CS-RX**) \$ 135.00 (Holds (7) C-Stands)
- C-Stand Holder Set Left Side (**GE-19 MINI CS-LX**) \$ 135.00 (Holds (6) C-Stands)
- Combo Stand Holder (**MINI CS-3**) \$ 65.00 (Holds (3) Combo Stands)
- Combo Stand Holder (**MINI CS-2**) \$ 54.00 (Holds (2) Combo Stands)
- Baby Stand Holder (**MINI ES-4**) \$ 65.00 (Holds (4) Baby Stands)
- Baby Stand Holder (**MINI ES-3**) \$ 54.00 (Holds (3) Baby Stands)
- 5/8" Baby Pin (**MAG-NP PIN**) \$ 13.00

Options:

- Milk Crate (**B-03**) \$ 20.00
- Full Milk Crate Liner (**B-04**) \$ 19.50
- Foam Filled Tires (**WA-10 FOAM OS** and **WA-08 FOAM CTR**) \$ 184.00

Replacement parts:

- 8" Pneumatic Tire (**WA-08 TIRE**) \$ 22.00
- 8" Pneumatic Tube (**WA-08 TUBE**) \$ 11.00
- 8" Pneumatic Swivel Caster Wheel (**W-08 SCX**) \$ 82.00
- 10" Pneumatic Tire (**WA-10 TIRE**) \$ 24.00
- 10" Pneumatic Tube (**WA-10 TUBE**) \$ 12.00
- 10" Pneumatic Offset Wheel (**W-10 OS34X**) \$ 65.00

Shipping Dimensions: L60" x W26" x H33" (149 lbs.)
L152.4cm x W66cm x H83.8cm (67.7 kgs.)



GE-19 MINI-X Shown with optional C-Stand Holders



GE-19 MINI-X Shown with optional Baby Stand Holders



GE-19 MINI-X Shown with optional Combo Stand Holders





C-Stand Mini Cart (Modular)

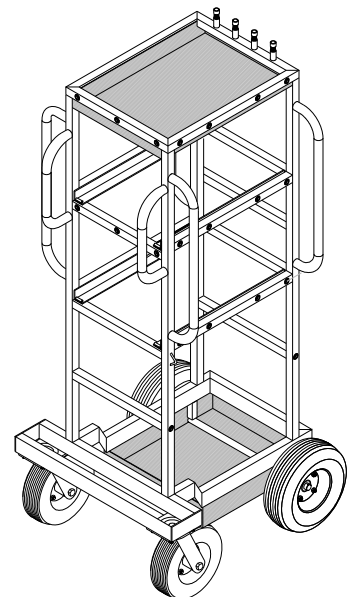
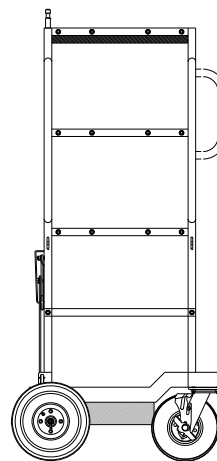
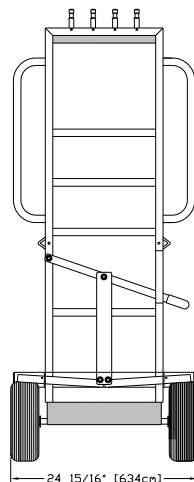
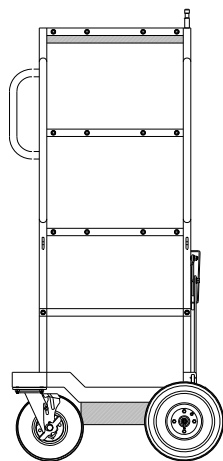
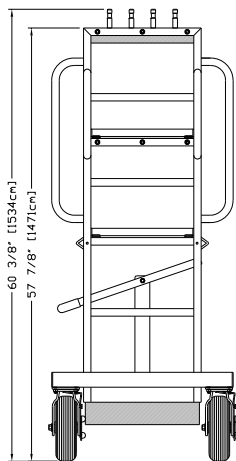
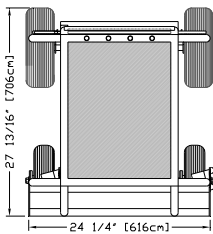
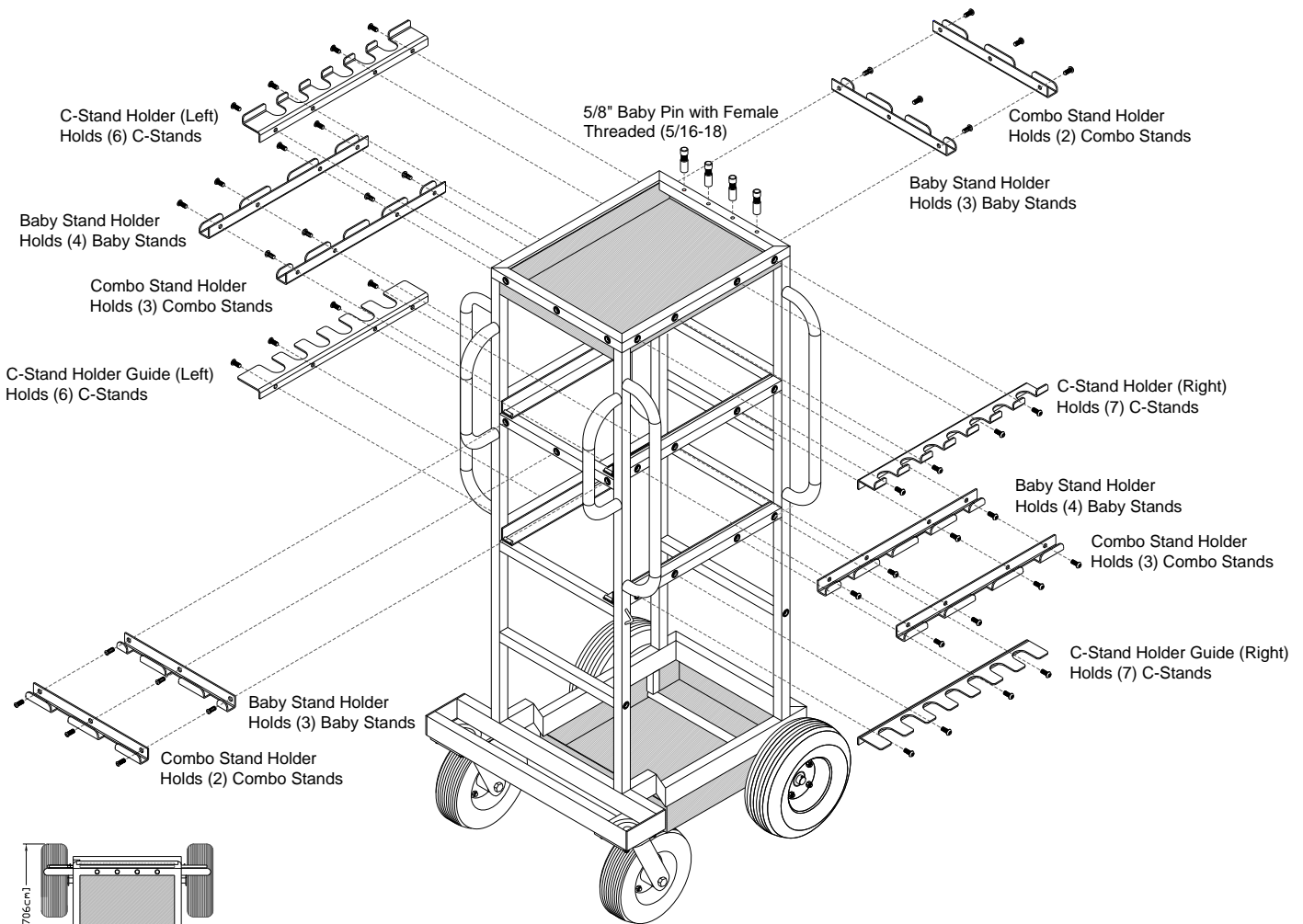



SkyPanel 60 Mini Cart

Part No. E-18 MINI AL

Sale Price: \$ 5,950.00

Material: Aluminum

Color: Black Texture

Max. Capacity: 1000 lbs. /454.6 kgs.

Weight: 273 lbs. / 124 kgs.

Dimensions: L48" x W21 1/4" x H51 1/4"
L122cm x W54cm x H130.2cm



Features:

- All Steel Construction
- Accommodates up to five (5) SkyPanel 60 or 30 Fixtures
- Accommodates up to five (5) Power Supplies and Cables
- Accommodates three (3) Full Size Milk Crates
- "D" Style Push / Pull Handles
- Wheels: (2) 10" Swivel Casters & (2) 10" Rigid Casters
- Jockey Box Holds (1) Half Milk Crate
- Locking Bars (2) keep SkyPanels secured in cart
- Foot Brake

Accessories:

Options:

- Full Milk Crate **(B-03)** \$ 20.00
- Half Milk Crate **(B-05)** \$ 20.00
- Full Milk Crate Liner **(B-04)** \$ 19.50
- Half Milk Crate Liner **(B-06)** \$ 19.00
- Foam Filled Tires (4) **(WA-10 FOAM CTR)** \$ 240.00

Replacement parts:

- 10" Pneumatic Tire **(WA-10 TIRE)** \$ 24.00
- 10" Pneumatic Tube **(WA-10 TUBE)** \$ 12.00
- 10" Pneumatic Rigid Caster Wheel **(W-10 RCX)** \$ 88.00
- 10" Pneumatic Swivel Caster Wheel **(W-10 SCX)** \$ 91.00

Shipping Dimensions: L49" x W22" x H57" (300 lbs.) Includes Pallet
L124.5cm x W55.9cm x H144.8cm (136.4 kgs.)





SkyPanel 60 Mini Cart (Cont.)

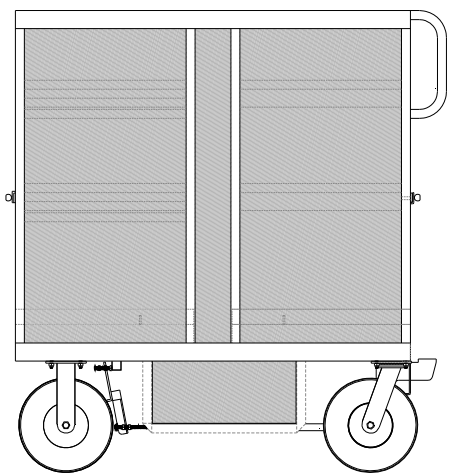
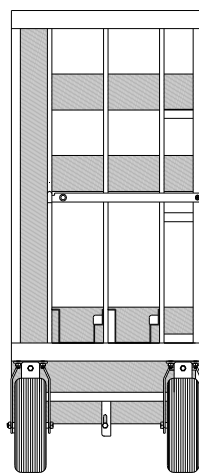
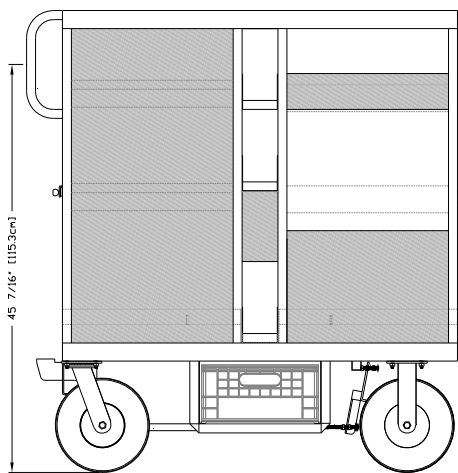
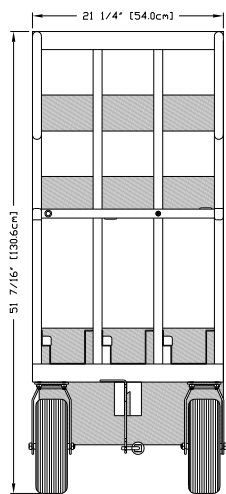
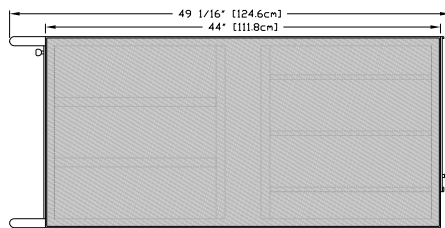
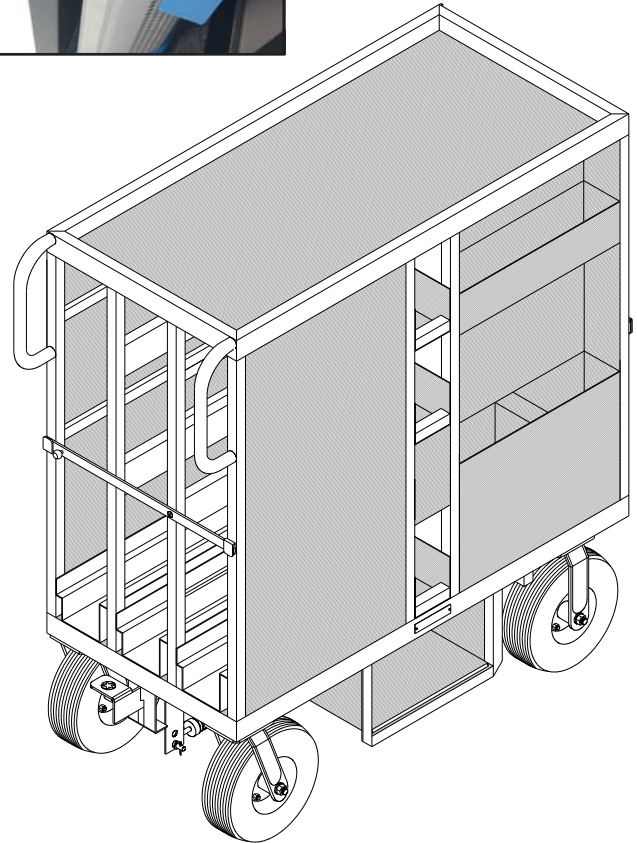



4 x 4 Mini Cart

Part No. G-01 MINI

Sale Price: \$ 1,950.00

Material: Steel

Color: Black Hammertone

Max. Capacity: 800 lbs. / 364 kgs.

Weight: 139 lbs. / 63.2 kgs.

Dimensions: L55 3/4" x W21 1/4" x H62 3/4"
L141.6cm x W54cm x H159.4cm

Features:

- Holds (28) 4 x 4 Flags
- Holds (2) Full Size Reflector Boards
- Top Gel Storage Pan (L51 3/4" x W20 3/4" / L131.5cm x W52.7cm)
- Wheels: (2) 8" Swivel Casters with Brake & (2) 8" Rigid Wheels

Accessories:

- Net Basket (18" x 24") (46cm x 61cm) Double **(B-01D)** \$ 515.00
- Net Basket (24" x 36") (61cm x 92cm) Double **(B-02D)** \$ 575.00
- Net Basket (24" x 36") (61cm x 92cm) Triple **(B-02T)** \$ 720.00
- Net Basket (24" x 36") (61cm x 92cm) Triple Mobile **(B-02T MOB)** \$ 850.00
- Gel Holder Detachable Rack (Holds (16) Gels) **(GEL G-01)** \$ 425.00

Options:

- Foam Filled Tires **(WA-08 FOAM CTR)** \$ 208.00

Replacement parts:

- 8" Pneumatic Tire **(WA-08 TIRE)** \$ 22.00
- 8" Pneumatic Tube **(WA-08 TUBE)** \$ 11.00
- 8" Pneumatic Rigid Caster Wheel **(W-08 RCX)** \$ 80.00
- 8" Pneumatic Swivel Caster Wheel with Brake **(W-08 SCBRX)** \$ 85.00

Shipping Dimensions: L56" x W22" x H68" (174 lbs.)
L142.2cm x W55.9cm x H172.7cm (79.1 kgs.)



Rear view image of G-01 MINI Cart with optional Net Basket (18" x 24") (46cm x 61cm) Double

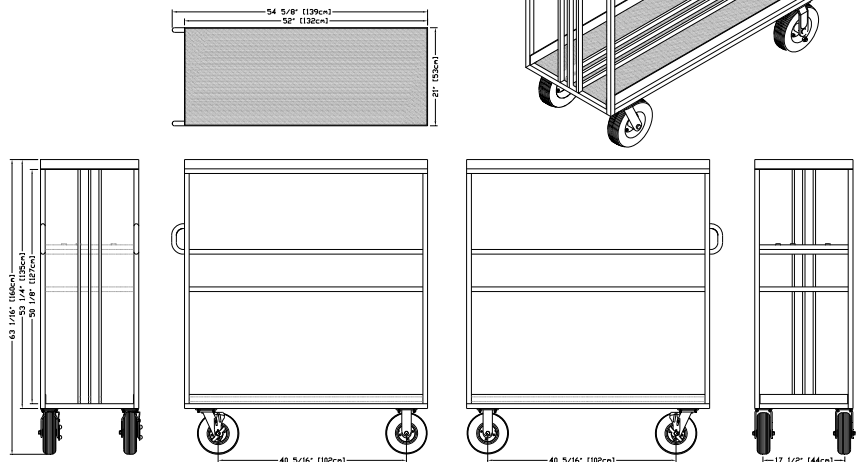
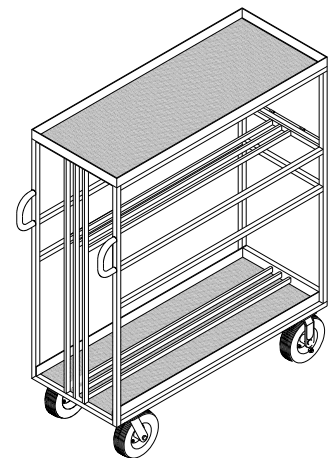



4 x 4 Mini Cart Plus

Part No. G-01 MINI 10

Sale Price: \$ 2,250.00

Material: Steel

Color: Black Hammertone

Max. Capacity: 1,000 lbs. / 454.4 kgs.

Weight: 169 lbs. / 76.8 kgs.

Dimensions: L56" x W21 1/4" x H65 3/8"
L142.2cm x W54cm x H166cm



Features:

- Holds (28) 4 x 4 Flags
- Holds (2) Full Size Reflector Boards
- Top Section Holds (3) Milk Crates
- Jockey Box Holds (1) Half Milk Crate
- Top Gel Storage Pan (L51 3/4" x W20 3/4" / L131.5cm x W52.7cm)
- Wheels: (2) 10" Swivel Casters & (2) 10" Rigid Wheels
- Foot Brake
- Net Basket (18" x 24") (46cm x 61cm) Double (**B-01D**) \$ 515.00
- Net Basket (24" x 36") (61cm x 92cm) Double (**B-02D**) \$ 575.00
- Net Basket (24" x 36") (61cm x 92cm) Triple (**B-02T**) \$ 720.00
- Net Basket (24" x 36") (61cm x 92cm) Triple Mobile (**B-02T MOB**) \$ 850.00
- Gel Holder Detachable Rack (Holds (16) Gels) (**GEL G-01**) \$ 425.00

Options:

- Full Milk Crate (**B-03**) \$ 20.00
- Half Milk Crate (**B-05**) \$ 20.00
- Full Milk Crate Liner (**B-04**) \$ 19.50
- Half Milk Crate Liner (**B-06**) \$ 19.00
- Foam Filled Tires (4) (**WA-10 FOAM CTR**) \$ 240.00

Replacement parts:

- 10" Pneumatic Tire (**WA-10 TIRE**) \$ 24.00
- 10" Pneumatic Tube (**WA-10 TUBE**) \$ 12.00
- 10" Pneumatic Rigid Caster Wheel (**W-10 RCX**) \$ 88.00
- 10" Pneumatic Swivel Caster Wheel (**W-10 SCX**) \$ 91.00

Shipping Dimensions: L57" x W22" x H71" (204 lbs.) Includes Pallet
L144.8cm x W55.9cm x H180.3cm (92.7 kgs.)



G-01 MINI 10 Shown with optional Net Basket & Milk Crates

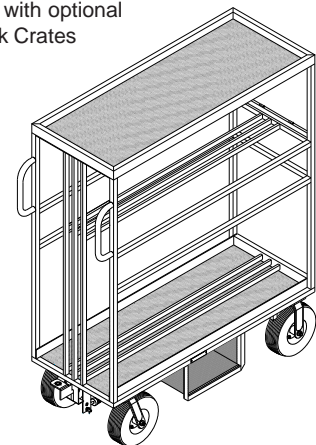
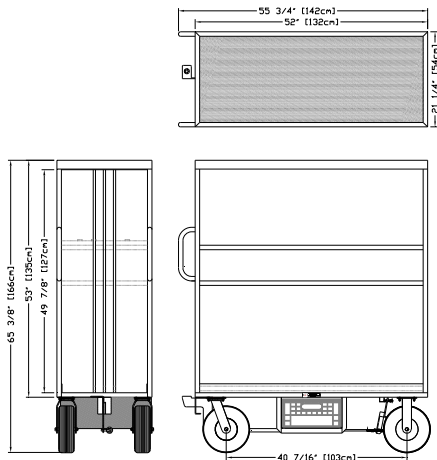



Combo Stand Mini Cart

Part No. GE-06 MINI

Sale Price: \$ 2,375.00

Material: Steel

Color: Black Hammertone

Max. Capacity: 1,000 lbs. / 454 kgs.

Weight: 137 lbs. / 62.3 kgs.

Dimensions: L48" x W21 1/4" x H50 5/8"

L122cm x W54cm x H128.6cm

Features:

- Holds (9) Junior Combo Stands
- Holds (21) Low Combo Stands
- Combo Stand Holders are interchangeable with Baby Stand Holders
- Jockey Box Holds (1) Half Milk Crate
- Wheels: (2) 10" Swivel Casters & (2) 10" Rigid Casters
- Foot Brake

Accessories:

- Combo Stand Holder (**MINI CS-3**) \$ 65.00
- Baby Stand Holder (**MINI ES-4**) \$ 65.00

Options:

- Half Milk Crate (**B-05**) \$ 20.00
- Half Milk Crate Liner (**B-06**) \$ 19.00
- Foam Filled Tires (**WA-10 FOAM CTR**) \$ 240.00

Replacement parts:

- 10" Pneumatic Tire (**WA-10 TIRE**) \$ 24.00
- 10" Pneumatic Tube (**WA-10 TUBE**) \$ 12.00
- 10" Pneumatic Rigid Caster Wheel (**W-10 RCX**) \$ 88.00
- 10" Pneumatic Swivel Caster Wheel (**W-10 SCX**) \$ 91.00

Shipping Dimensions: L49" x W22" x H56" (188 lbs.)

L125cm x W56cm x H143cm (85.5 kgs.)



NOTE: Milk Crates not included

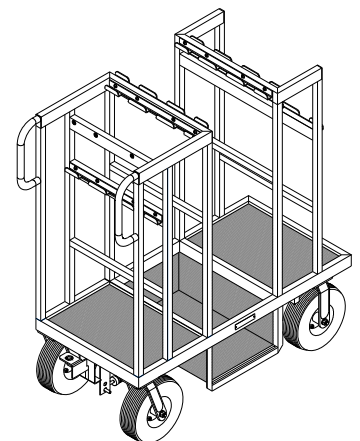

Rear view image of GE-06 MINI Cart

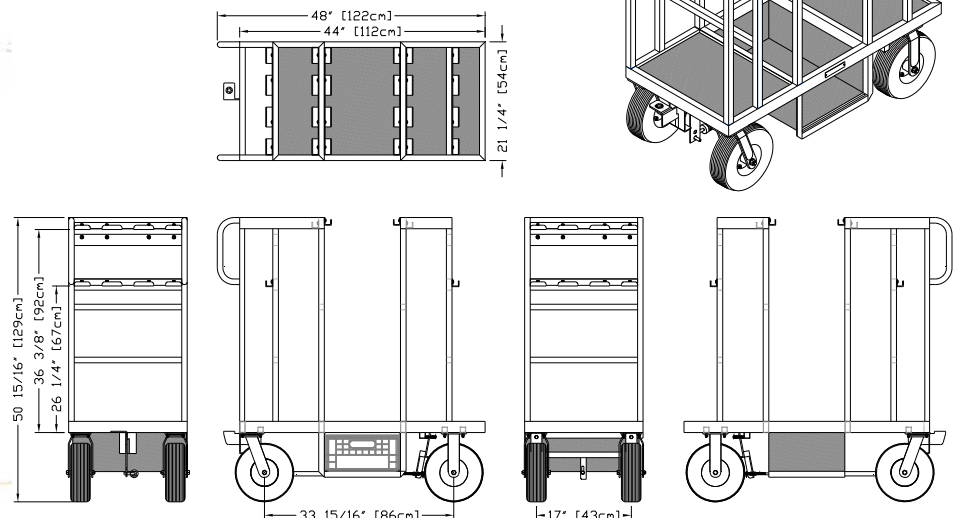



Baby Stand Mini Cart

Part No. E-16 MINI

Sale Price: \$ 2,075.00

Material: Steel

Color: Black Hammertone

Max. Capacity: 1,000 lbs. / 454 kgs.

Weight: 129 lbs. / 58.6 kgs.

Dimensions: L48" x W21 1/4" x H50 5/8"
L122cm x W54cm x H128.6cm

Features:

- Holds (28) Baby Stands
- Baby Stand Holders are interchangeable with Combo Stand Holders
- Jockey Box Holds (1) Half Milk Crate
- Wheels: (2) 10" Swivel Casters & (2) 10" Rigid Casters
- Foot Brake

Accessories:

- Baby Stand Holder (MINI ES-4) \$ 65.00
- Combo Stand Holder (MINI CS-3) \$ 65.00

Options:

- Half Milk Crate (B-05) \$ 20.00
- Half Milk Crate Liner (B-06) \$ 19.00
- Foam Filled Tires (WA-10 FOAM CTR) \$ 240.00

Replacement parts:

- 10" Pneumatic Tire (WA-10 TIRE) \$ 24.00
- 10" Pneumatic Tube (WA-10 TUBE) \$ 12.00
- 10" Pneumatic Rigid Caster Wheel (W-10 RCX) \$ 88.00
- 10" Pneumatic Swivel Caster Wheel (W-10 SCX) \$ 91.00

Shipping Dimensions: L49" x W22" x H56" (188 lbs.)
L124.5cm x W55.9cm x H142.2cm (85.5 kgs.)



NOTE: Milk Crates not included



Rear view image of E-16 MINI Cart

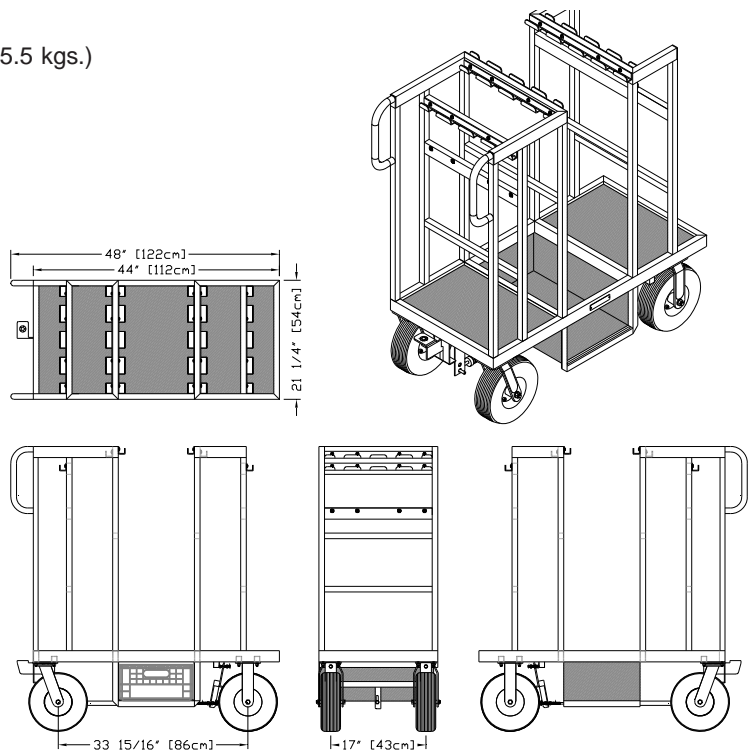



Super Duz-All Mini Cart

Part No. G-02 MINI AL

Sale Price: \$ 3,250.00

Material: Aluminum

Color: Black Hammertone

Max. Capacity: 1,000 lbs. / 454 kgs.

Weight: 214 lbs. / 97.3 kgs.

Dimensions: L48" x W21 1/4" x H64 1/2"
L122cm x W54cm x H164cm

Features:

- Top Storage Section (L42" x W21" / 107cm x W53.3cm)
- Bottom Storage Section (L27 1/2" x W19" / 70cm x W48.3cm)
- (1) Adjustable Aluminum Shelf (L27 3/8" x W20 3/4" / 69.5cm x W52.7cm)
- C-Stand Bracket Holds (7) C-Stands
- Holds (8) 4 x 4 Flags
- Holds (8) 4 x 4 Flags
- 3 Sliding Milk Crate Compartments
- Shelves hold additional Milk Crates, Apple Boxes, Sand Bags, Rags, Cables
- Jockey Box Holds (1) Half Milk Crate
- Wheels: (2) 10" Swivel Casters & (2) 10" Rigid Casters
- Foot Brake

Accessories:

- Net Basket Double (**B-02D**) \$ 575.00
- Net Basket Triple (**B-02T**) \$ 720.00
- Net Basket Triple Mobile (**B-02T MOB**) \$ 850.00
- Baby Stand Holder (**MINI ES-4**) \$ 65.00
- Additional Aluminum Adjustable Shelf (**G-02 MINI AL E**) \$ 365.00

Options:

- Milk Crate (**B-03**) \$ 20.00
- Half Milk Crate (**B-05**) \$ 20.00
- Full Milk Crate Liner (**B-04**) \$ 19.50
- Half Milk Crate Liner (**B-06**) \$ 19.00
- Foam Filled Tires (**WA-10 FOAM CTR**) \$ 240.00

Replacement parts:

- 10" Pneumatic Tire (**WA-10 TIRE**) \$ 24.00
- 10" Pneumatic Tube (**WA-10 TUBE**) \$ 12.00
- 10" Pneumatic Rigid Caster Wheel (**W-10 RCX**) \$ 88.00
- 10" Pneumatic Swivel Caster Wheel (**W-10 SCX**) \$ 91.00

Shipping Dimensions: L49" x W22" x H70" (264 lbs.)
L125cm x W56cm x H178cm (120 kgs.)



NOTE: Milk Crates not included

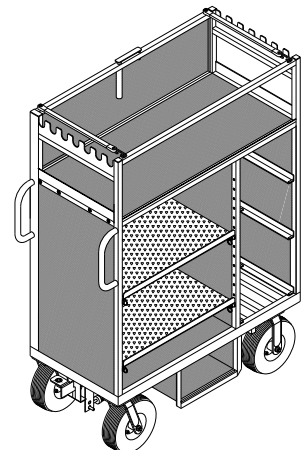

Rear view image of G-02 MINI Cart

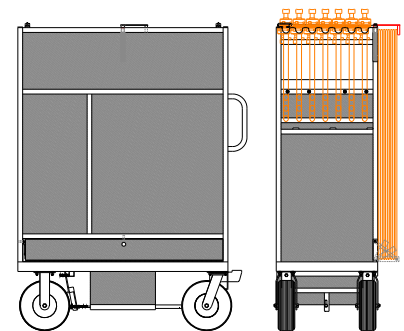
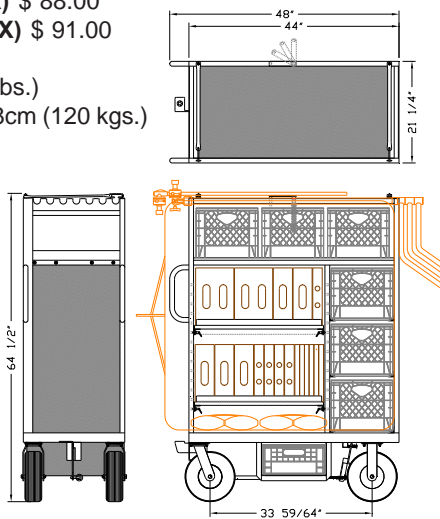



HMI Mini Cart

Part No. E-03 MINI

Sale Price: \$ 2,375.00

Material: Steel

Color: Black Hammertone

Max. Capacity: 1,000 lbs. / 454 kgs.

Weight: 150 lbs. / 68.2 kgs.

Dimensions: L48" x W21 1/4" x H62 3/8"
L122cm x W54cm x H158.4cm

Features:

- Top Storage Pan (D19 1/4 x W34" / D48.9cm x W86.4cm)
- 2 Shelves (L33 3/4" x W21 1/4" / L85.7cm x W54cm) 1 Stationary, 1 Adjustable
- Combo Stand Holder holds (4) Combo Stands
- Jockey Box Holds (1) Half Milk Crate
- 6 HMI Head Feeder Cable Holders
- Wheels: (2) 10" Swivel Casters & (2) 10" Rigid Casters
- Foot Brake

Accessories:

- Additional Adjustable Shelf (**E-03 MINI SHELF AL**) \$ 325.00

Options:

- Milk Crate (**B-03**) \$ 20.00
- Half Milk Crate (**B-05**) \$ 20.00
- Full Milk Crate Liner (**B-04**) \$ 19.50
- Half Milk Crate Liner (**B-06**) \$ 19.00
- Foam Filled Tires (**WA-10 FOAM CTR**) \$ 240.00

Replacement parts:

- 10" Pneumatic Tire (**WA-10 TIRE**) \$ 24.00
- 10" Pneumatic Tube (**WA-10 TUBE**) \$ 12.00
- 10" Pneumatic Rigid Caster Wheel (**W-10 RCX**) \$ 88.00
- 10" Pneumatic Swivel Caster Wheel (**W-10 SCX**) \$ 91.00

Shipping Dimensions: L49" x W22" x H68" (200 lbs.)
L125cm x W56cm x H172.7cm (91 kgs.)



NOTE: Milk Crates not included

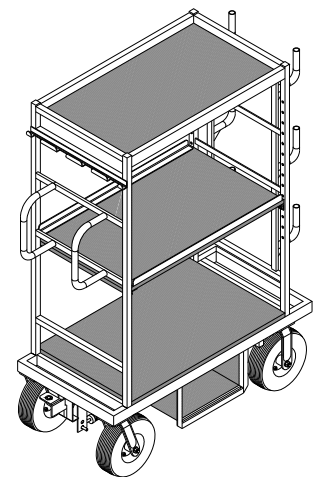

Rear view image of E-03 MINI Cart

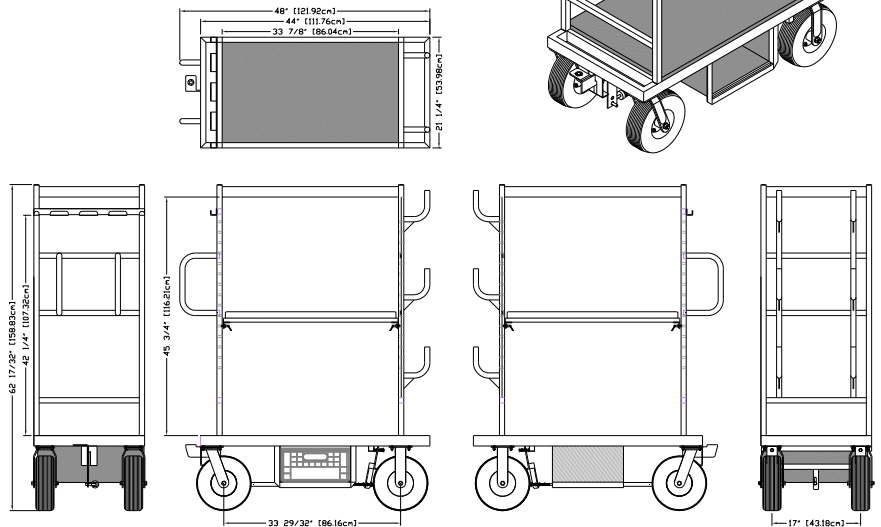



4-Crate Set Box Mini Cart

Part No. SB-04H MINI

Sale Price: \$ 2,775.00

Material: Steel

Color: Black Hammertone

Max. Capacity: 1,000 lbs. / 454 kgs.

Weight: 199 lbs. / 90.5 kgs.

Dimensions: L48" x W21 1/4" x H39 3/4"
L122cm x W54cm x H101cm

Features:

- 3 Full Extension Drawers with Push to Open Drawer Slides (D17" x W27 1/4" x H3 1/4" / D43.2cm x W69.2cm x H8.3cm)
- Pull-out Work Board with Push to Open Drawer Slides
- Top Pan Holds (3) Milk Crates (D19 1/4 x W42" x H1 1/2" / D48.9cm x W106.7cm x H3.8cm)
- 4 Sliding Milk Crate Compartments
- Wheels: (2) 10" Swivel Casters & (2) 10" Rigid Casters
- Jockey Box Holds (1) Half Milk Crate
- Foot Brake

Accessories:

- Gel Holder (Single) (**GEL SB-S**) \$ 245.00
- Gel Holder (Double) (**GEL SB-D**) \$ 325.00

Options:

- Milk Crate (**B-03**) \$ 20.00
- Half Milk Crate (**B-05**) \$ 20.00
- Full Milk Crate Liner (**B-04**) \$ 19.50
- Half Milk Crate Liner (**B-06**) \$ 19.00
- Foam Filled Tires (**WA-10 FOAM CTR**) \$ 240.00

Replacement parts:

- 10" Pneumatic Tire (**WA-10 TIRE**) \$ 24.00
- 10" Pneumatic Tube (**WA-10 TUBE**) \$ 12.00
- 10" Pneumatic Rigid Caster Wheel (**W-10 RCX**) \$ 88.00
- 10" Pneumatic Swivel Caster Wheel (**W-10 SCX**) \$ 91.00
- Full Size Aluminum Set Box Drawer (**DRAWER-01 AL**) \$ 255.00

Shipping Dimensions: L49" x W22" x H45" (249 lbs.)
L125cm x W56cm x H114.3cm (113 kgs.)



NOTE: Milk Crates not included

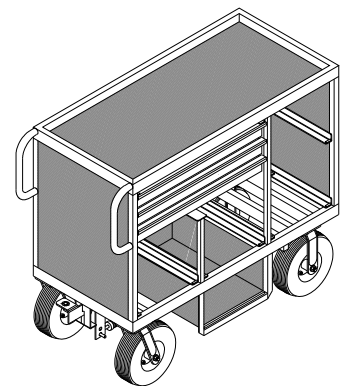

Rear view image of SB-04H MINI Cart

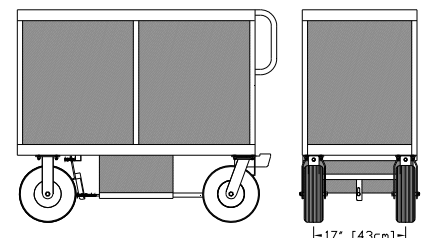
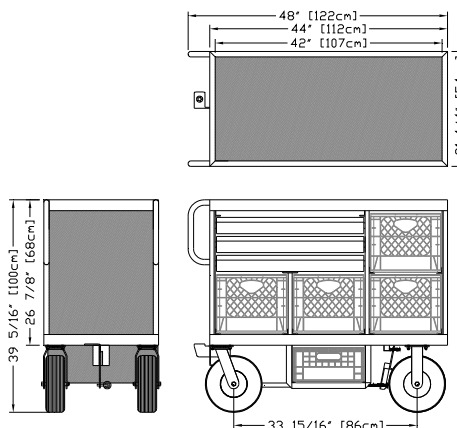



6-Crate Set Box Mini Cart

Part No. SB-06H MINI

Sale Price: \$ 2,175.00

Material: Steel

Color: Black Hammertone

Max. Capacity: 1,000 lbs. / 454 kgs.

Weight: 157 lbs. / 71.4 kgs.

Dimensions: L48" x W21 1/4" x H39 3/4"
L122cm x W54cm x H101cm

Features:

- Top Pan Holds (3) Milk Crates
(D19 1/4 x W42" x H1 1/2" / D48.9cm x W106.7cm x H3.8cm)
- 6 Sliding Milk Crate Compartments
- Wheels: (2) 10" Swivel Casters & (2) 10" Rigid Casters
- Jockey Box Holds (1) Half Milk Crate
- Foot Brake

Accessories:

- Gel Holder (Single) (**GEL SB-S**) \$ 245.00
- Gel Holder (Double) (**GEL SB-D**) \$ 325.00

Options:

- Milk Crate (**B-03**) \$ 20.00
- Half Milk Crate (**B-05**) \$ 20.00
- Full Milk Crate Liner (**B-04**) \$ 19.50
- Half Milk Crate Liner (**B-06**) \$ 19.00
- Foam Filled Tires (**WA-10 FOAM CTR**) \$ 240.00

Replacement parts:

- 10" Pneumatic Tire (**WA-10 TIRE**) \$ 24.00
- 10" Pneumatic Tube (**WA-10 TUBE**) \$ 12.00
- 10" Pneumatic Rigid Caster Wheel (**W-10 RCX**) \$ 88.00
- 10" Pneumatic Swivel Caster Wheel (**W-10 SCX**) \$ 91.00

Shipping Dimensions: L49" x W22" x H45" (207 lbs.)
L125cm x W56cm x H114.3cm (94 kgs.)



NOTE: Milk Crates not included



Rear view image of SB-06 MINI Cart

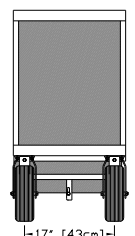
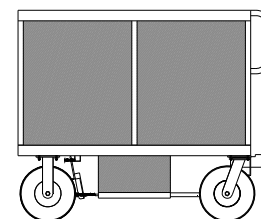
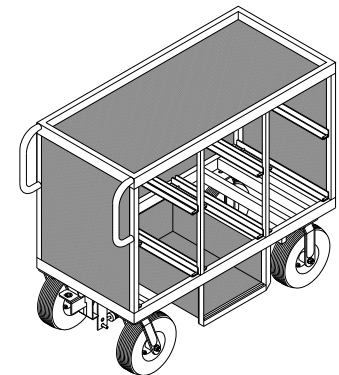
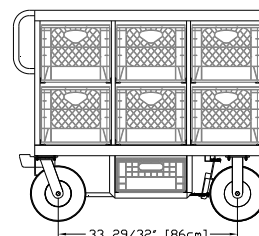
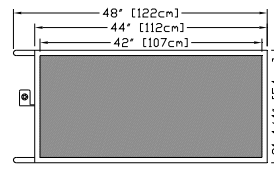
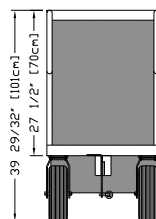



7-Crate Set Box Mini Cart

Part No. SB-07 MINI

Sale Price: \$ 2,850.00

Material: Steel

Color: Black Hammertone

Max. Capacity: 1,000 lbs. / 454 kgs.

Weight: 227 lbs. / 103.2 kgs.

Dimensions: L48" x W21 1/4" x H51 1/2"
L122cm x W54cm x H130.8cm

Features:

- 3 Full Extension Drawers with Push to Open Drawer Slides (D17" x W27 1/4" x H3 1/4" / D43.2cm x W69.2cm x H8.3cm)
- Pull-out Work Board with Push to Open Drawer Slides
- Top Pan Holds (3) Milk Crates (D19 1/4 x W42" x H1 1/2" / D48.9cm x W106.7cm x H3.8cm)
- 7 Sliding Milk Crate Compartments
- Wheels: (2) 10" Swivel Casters & (2) 10" Rigid Casters
- Jockey Box Holds (1) Half Milk Crate
- Foot Brake

Accessories:

- Gel Holder (Single) (**GEL SB-S**) \$ 245.00
- Gel Holder (Double) (**GEL SB-D**) \$ 325.00
- Baby Stand Holder (Holds 4 Stands) (**MINI ES-4**) \$ 65.00

Options:

- Milk Crate (**B-03**) \$ 20.00
- Half Milk Crate (**B-05**) \$ 20.00
- Full Milk Crate Liner (**B-04**) \$ 19.50
- Half Milk Crate Liner (**B-06**) \$ 19.00
- Foam Filled Tires (**WA-10 FOAM CTR**) \$ 240.00
- Rear Fold-Down Table (**TB-42**) \$ 428.00

Replacement parts:

- 10" Pneumatic Tire (**WA-10 TIRE**) \$ 24.00
- 10" Pneumatic Tube (**WA-10 TUBE**) \$ 12.00
- 10" Pneumatic Rigid Caster Wheel (**W-10 RCX**) \$ 88.00
- 10" Pneumatic Swivel Caster Wheel (**W-10 SCX**) \$ 91.00
- Full Size Aluminum Set Box drawer (**DRAWER-01 AL**) \$ 255.00

Shipping Dimensions: L49" x W22" x H57" (277 lbs.)
L125cm x W56cm x H144.7cm (126 kgs.)



NOTE: Milk Crates not included

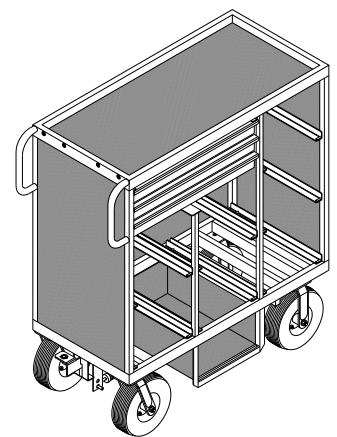

Rear view image of SB-07 MINI Cart

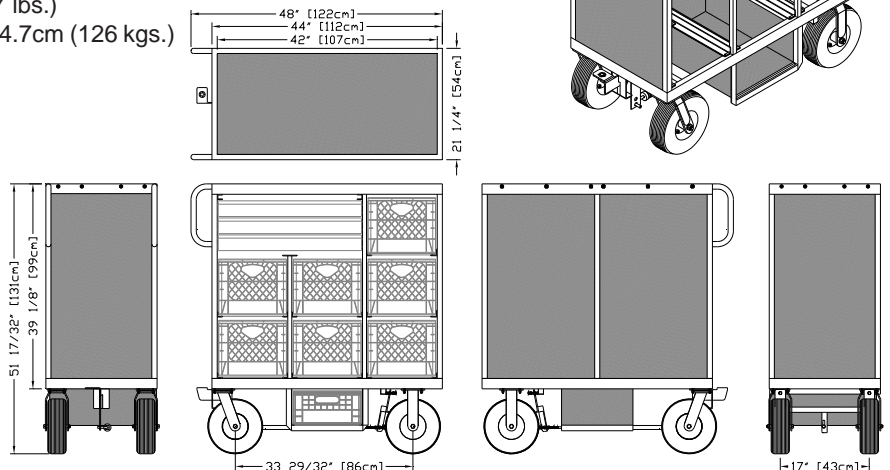



9-Crate Set Box Mini Cart

Part No. SB-09 MINI

Sale Price: \$ 2,795.00

Material: Steel

Color: Black Hammertone

Max. Capacity: 1,000 lbs. / 454 kgs.

Weight: 187 lbs. / 85 kgs.

Dimensions: L48" x W21 1/4" x H51 1/2"
L122cm x W54cm x H130.8cm

Features:

- Top Pan Holds (3) Milk Crates
(D19 1/4 x W42" x H1 1/2" / D48.9cm x W106.7cm x H3.8cm)
- 9 Sliding Milk Crate Compartments
- Wheels: (2) 10" Swivel Casters & (2) 10" Rigid Casters
- Jockey Box Holds (1) Half Milk Crate
- Foot Brake

Accessories:

- Gel Holder (Single) (**GEL SB-S**) \$ 245.00
- Gel Holder (Double) (**GEL SB-D**) \$ 325.00
- Baby Stand Holder (Holds 4 Stands) (**MINI ES-4**) \$ 65.00

Options:

- Milk Crate (**B-03**) \$ 20.00
- Half Milk Crate (**B-05**) \$ 20.00
- Full Milk Crate Liner (**B-04**) \$ 19.50
- Half Milk Crate Liner (**B-06**) \$ 19.00
- Foam Filled Tires (**WA-10 FOAM CTR**) \$ 240.00
- Rear Fold-Down Table (**TB-42**) \$ 428.00

Replacement parts:

- 10" Pneumatic Tire (**WA-10 TIRE**) \$ 24.00
- 10" Pneumatic Tube (**WA-10 TUBE**) \$ 12.00
- 10" Pneumatic Rigid Caster Wheel (**W-10 RCX**) \$ 88.00
- 10" Pneumatic Swivel Caster Wheel (**W-10 SCX**) \$ 91.00

Shipping Dimensions: L49" x W22" x H57" (237 lbs.)
L125cm x W56cm x H144.7cm (107.7 kgs.)



NOTE: Milk Crates not included

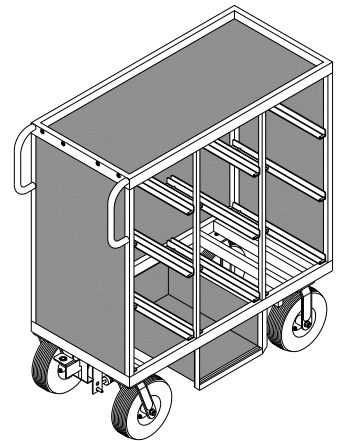

Rear view image of SB-09 MINI Cart

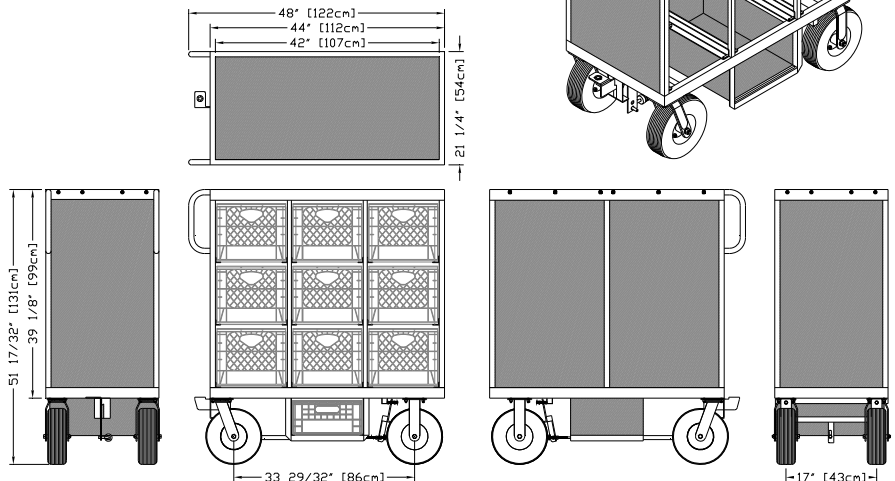



Electrician's Cart

Part No. E-01

Sale Price: \$ 2,375.00

Material: Steel

Color: Black Hammertone

Max. Capacity: 1,000 lbs. / 454 kgs.

Weight: 230 lbs. / 98 kgs.

Dimensions: L61 1/8" x W28 1/2" x H63"
L155.3cm x W72.4cm x H160cm

Features:

- (6) Sliding Milk Crate Compartments
- Top Tray (D18" x W28 1/4" x H13") (D45.7cm x W71.8cm x H33cm)
- End Pans (D13" x W18") (D33cm x W45.7cm)
- Rear Storage (L55" x W7") (L139.7cm x W17.8cm)
- Jockey Box Holds (2) Half Milk Crates
- Wheels (2) 10" Swivel Casters & (2) 10" Rigid Casters
(Optional (2) 10" Swivel Casters & (4) 10" Rigid Casters)
- Foot Brake
- Pull Bar
- Locking Bar

Accessories:

Options:

- Rear Fold-Down Table **(TB-42)** \$ 428.00
- Milk Crate **(B-03)** \$ 20.00
- Half Milk Crate **(B-05)** \$ 20.00
- Full Milk Crate Liner **(B-04)** \$ 19.50
- Half Milk Crate Liner **(B-06)** \$ 19.00
- Foam Filled Tires **(WA-10 FOAM CTR)** \$ 240.00
- Additional (2) 10" Pneumatic Rigid Caster Wheel **(W-10 RCX)** \$ 176.00
- Additional (2) 10" Foam Filled Tires **(WA-10 FOAM CTR)** \$ 120.00

Replacement parts:

- 10" Pneumatic Tire **(WA-10 TIRE)** \$ 24.00
- 10" Pneumatic Tube **(WA-10 TUBE)** \$ 12.00
- 10" Pneumatic Rigid Caster Wheel **(W-10 RCX)** \$ 88.00
- 10" Pneumatic Swivel Caster Wheel **(W-10 SCX)** \$ 91.00

Shipping Dimensions: L62" x W29" x H64" (255 lbs.)

L157.5cm x W73.7cm x H162.6cm (115.9 kgs.)



NOTE: Milk Crates not included



SkyPanel 120 Cart

Part No. E-17

Sale Price: \$ 5,975.00

Material: Steel

Color: Black Texture

Max. Capacity: 1000 lbs. /454.6 kgs.

Weight: 476 lbs. / 216.4 kgs.

Dimensions: L60" x W28" x H75"

L152.4cm x W71.1cm x H190.5cm

Features:

- All Steel Construction
- Accommodates up to eight (8) SkyPanel 120 or 60 or 30 Fixtures
- Accommodates up to eight (8) SkyPanel 60 and eight (8) SkyPanel 30 Fixtures with optional SkyPanel Stackable Shelves
- Accommodates up to sixteen (16) SkyPanel 30 with optional SkyPanel Stackable Shelves
- Accommodates up to eight (8) Power Supplies and Cables
- "D" Style Push / Pull Handles
- Wheels: (2) 10" Swivel Casters & (2) 10" Rigid Casters
- Jockey Box Holds (2) Half Milk Crates
- Locking Bars (4) keep SkyPanels secured in cart
- Foot Brake

Accessories:

- SkyPanel Stackable Shelf (E-17 B) \$ 165.00

Options:

- Half Milk Crate (B-05) \$ 20.00
- Half Milk Crate Liner (B-06) \$ 19.00
- Foam Filled Tires (4) (WA-10 FOAM CTR) \$ 240.00

Replacement parts:

- 10" Pneumatic Tire (WA-10 TIRE) \$ 24.00
- 10" Pneumatic Tube (WA-10 TUBE) \$ 12.00
- 10" Pneumatic Rigid Caster Wheel (W-10 RCX) \$ 88.00
- 10" Pneumatic Swivel Caster Wheel (W-10 SCX) \$ 91.00
- Locking Bar (E-17 C) \$ 72.00

Shipping Dimensions: L57" x W29" x H80" (494 lbs.) Includes Pallet
L144.8cm x W73.7cm x H203.2cm (224.6 kgs.)

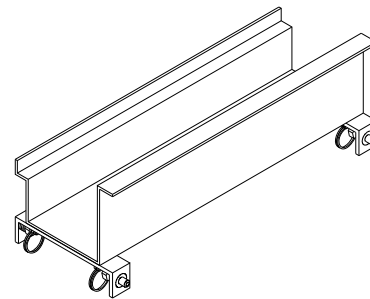

SkyPanel Stackable Shelf (E-17 B) \$ 165.00





SkyPanel 120 Cart (Cont.)

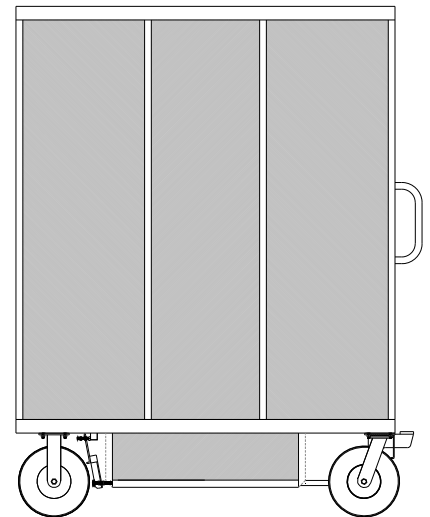
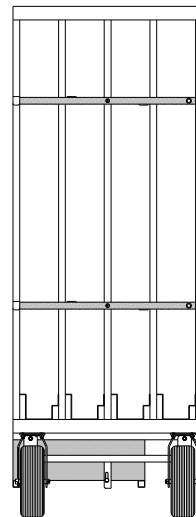
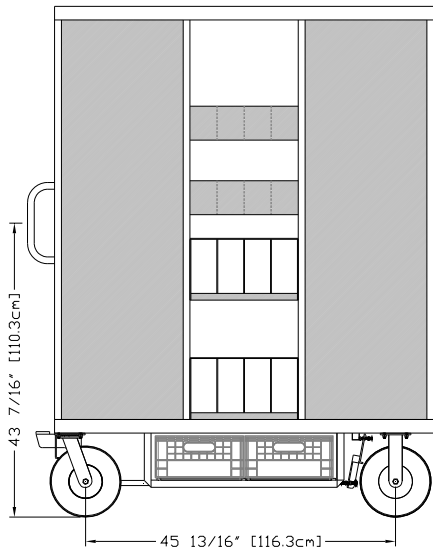
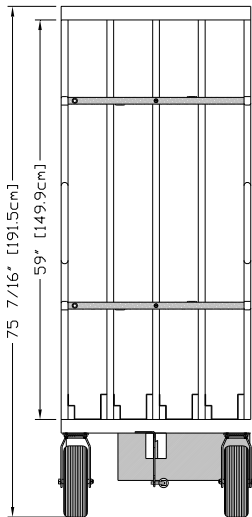
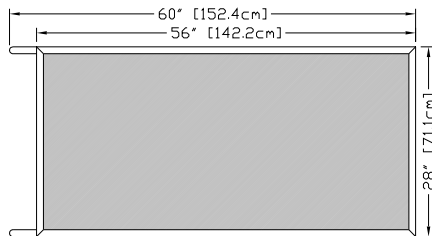
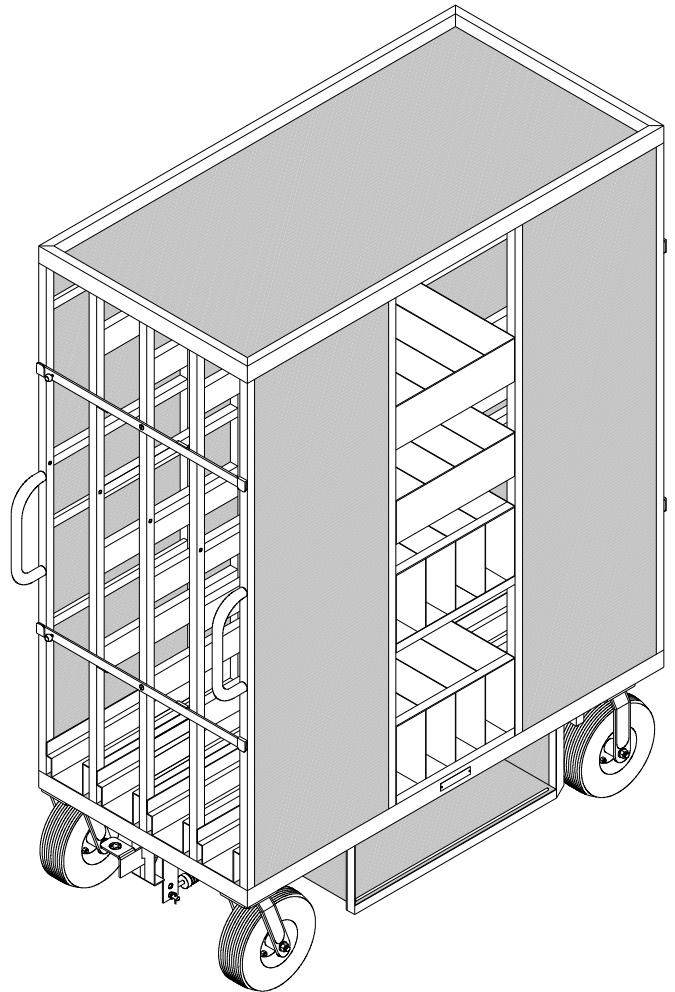



SkyPanel 360 Cart (Dual)

Part No. E-19

Sale Price: \$ 5,975.00

Material: Steel

Color: Black Texture

Max. Capacity: 1000 lbs. /454.6 kgs.

Weight: 435 lbs. / 197.7 kgs.

Dimensions: L68" x W30" x H66"

L172.7cm x W76.2cm x H167.6cm

Features:

- All Steel Construction
- Accomodates (2) SkyPanel 360
- Accomodates (2) Power Supply Units and Cables
- Accomodates up to (11) SkyPanel 360 Diffusion or/and Intensifiers
- Accomodates (2) Short Yokes
- "D" Style Push / Pull Handles
- Wheels: (2) 10" Swivel Casters & (2) 10" Rigid Casters
- Jockey Box Holds (2) Half Milk Crates
- Locking Bars (3) keeps SkyPanels and Diffusion secured in cart
- Foot Brake

Accessories:

Options:

- Half Milk Crate **(B-05)** \$ 20.00
- Half Milk Crate Liner **(B-06)** \$ 19.00
- Foam Filled Tires (4) **(WA-10 FOAM CTR)** \$ 240.00

Replacement parts:

- 10" Pneumatic Tire **(WA-10 TIRE)** \$ 24.00
- 10" Pneumatic Tube **(WA-10 TUBE)** \$ 12.00
- 10" Pneumatic Rigid Caster Wheel **(W-10 RCX)** \$ 88.00
- 10" Pneumatic Swivel Caster Wheel **(W-10 SCX)** \$ 91.00
- Locking Bar **(E-19 G CTR)** \$ 39.00

Shipping Dimensions: L69" x W31" x H72" (480 lbs.) Includes Pallet
L175.3cm x W78.8cm x H182.9cm (218.2 kgs.)



NOTE: Milk Crates not included

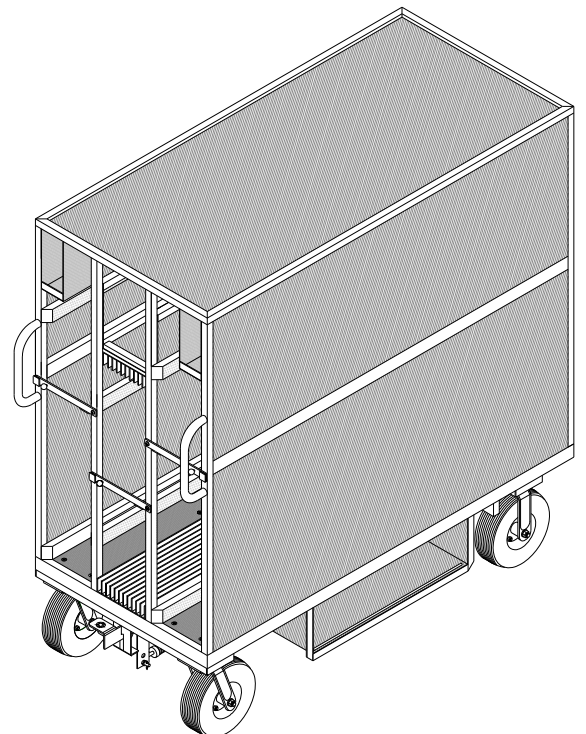
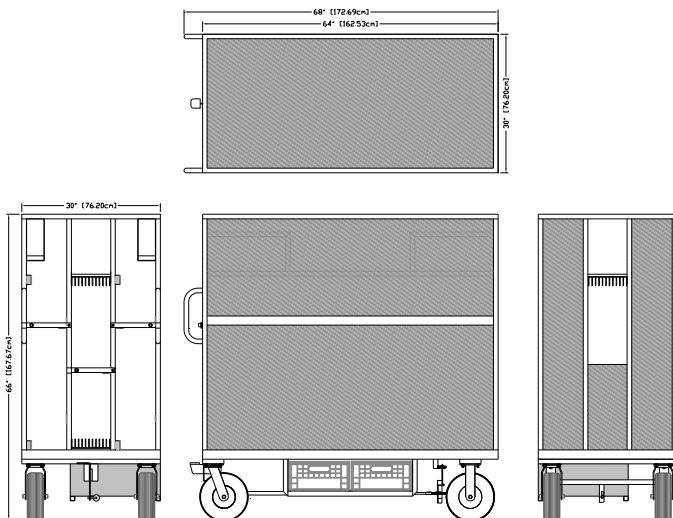



SkyPanel 360 Cart (Single)

Part No. E-20

Sale Price: \$ 5,675.00

Material: Steel

Color: Black Texture

Max. Capacity: 1000 lbs. /454.6 kgs.

Weight: 375 lbs. / 170.5 kgs.

Dimensions: L68" x W21 1/4" x H66"

L172.7cm x W54cm x H167.6cm



NOTE: Milk Crates not included

Features:

- All Steel Construction
- Accomodates (1) SkyPanel 360
- Accomodates (1) Power Supply Unit and Cables
- Accomodates up to (11) SkyPanel 360 Diffusion or/and Intensifiers
- Accomodates (1) Short Yoke
- "D" Style Push / Pull Handles
- Wheels: (2) 10" Swivel Casters & (2) 10" Rigid Casters
- Jockey Box Holds (2) Half Milk Crates
- Locking Bars (2) keeps SkyPanel and Diffusion secured in cart
- Foot Brake

Accessories:

Options:

- Half Milk Crate (B-05) \$ 20.00
- Half Milk Crate Liner (B-06) \$ 19.00
- Foam Filled Tires (4) (WA-10 FOAM CTR) \$ 240.00

Replacement parts:

- 10" Pneumatic Tire (WA-10 TIRE) \$ 24.00
- 10" Pneumatic Tube (WA-10 TUBE) \$ 12.00
- 10" Pneumatic Rigid Caster Wheel (W-10 RCX) \$ 88.00
- 10" Pneumatic Swivel Caster Wheel (W-10 SCX) \$ 91.00
- Locking Bar (E-19 G CTR) \$ 39.00

Shipping Dimensions: L69" x W22" x H72" (422 lbs.) Includes Pallet
L175.3cm x W55.9cm x H182.9cm (191.8 kgs.)

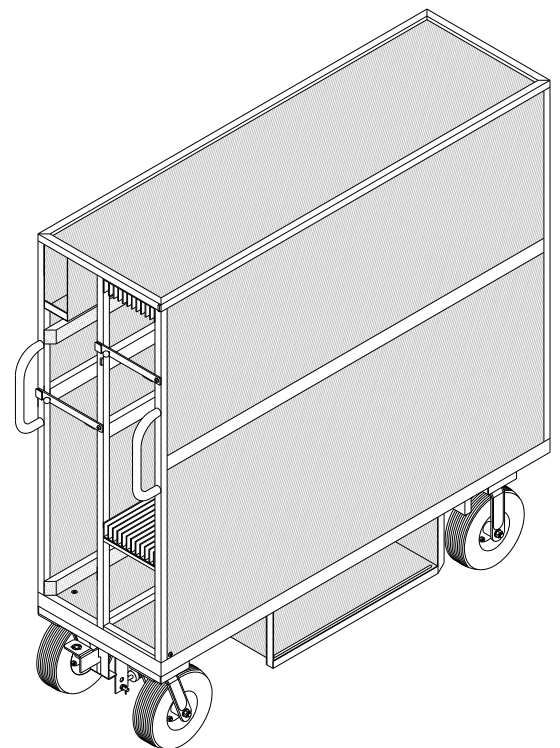
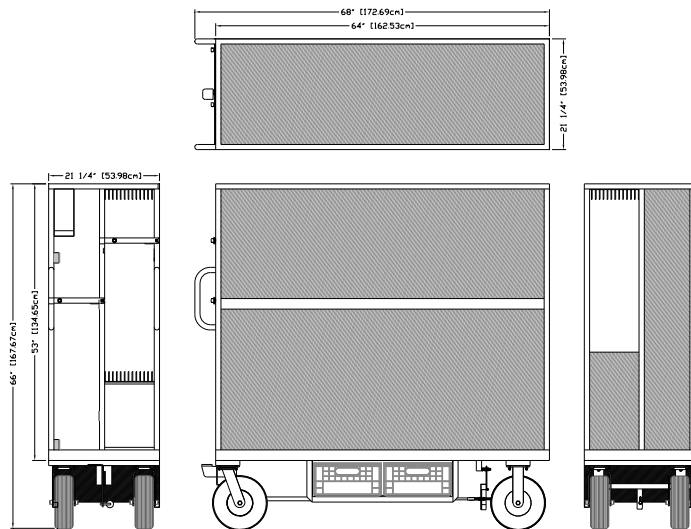



Combo Stand Cart

Part No. GE-06

Sale Price: \$ 2,350.00

Material: Steel

Color: Black Hammertone

Max. Capacity: 1,000 lbs. / 454 kgs.

Weight: 135 lbs. / 61.4 kgs.

Dimensions: L48" x W28" x H50 5/8"
L121.9cm x W71.1cm x H128.6cm

Features:

- Holds (15) Junior Combo Stands & (31) Low Combo Stands
- Combo Stand Holders can be switched with Baby Stand Holders (see accessories)
- Jockey Box Holds (1) Half Milk Crate (When not using 3-Riser Combo Stands)
- Wheels (2) 10" Swivel Casters & (2) 10" Rigid Casters
(Optional (2) 10" Swivel Casters & (4) 10" Rigid Casters)
- Foot Brake

Accessories:

- Baby Stand Holder **(ES-5)** Holds (5) Baby Stands \$ 70.00
- Baby Stand Holder **(ES-6)** Holds (6) Baby Stands \$ 70.00

Options:

- Half Milk Crate **(B-05)** \$ 20.00
- Half Milk Crate Liner **(B-06)** \$ 19.00
- Foam Filled Tires **(WA-10 FOAM CTR)** \$ 240.00
- Additional (2) 10" Pneumatic Rigid Caster Wheel **(W-10 RCX)** \$ 176.00
- Additional (2) 10" Foam Filled Tires **(WA-10 FOAM CTR)** \$ 120.00

Replacement parts:

- 10" Pneumatic Tire **(WA-10 TIRE)** \$ 24.00
- 10" Pneumatic Tube **(WA-10 TUBE)** \$ 12.00
- 10" Pneumatic Rigid Caster Wheel **(W-10 RCX)** \$ 88.00
- 10" Pneumatic Swivel Caster Wheel **(W-10 SCX)** \$ 91.00

Shipping Dimensions: L49" x W29" x H53" (175 lbs.)
L124.5cm x W73.7cm x H134.6cm (79.5 kgs.)



NOTE: Milk Crates not included

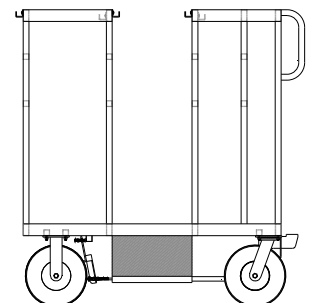
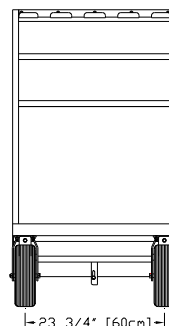
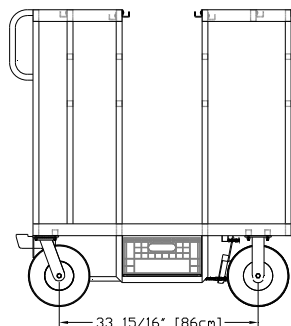
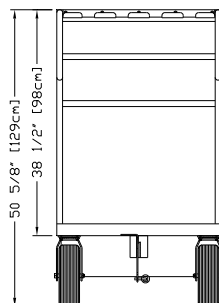
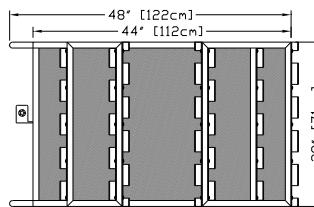
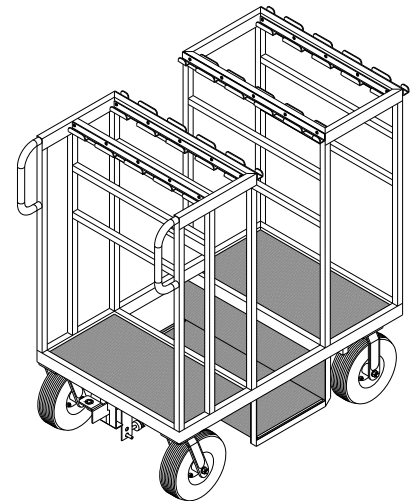



Baby Stand Cart

Part No. E-16

Sale Price: \$ 2,350.00

Material: Steel

Color: Black Hammertone

Max. Capacity: 1,000 lbs. / 454 kgs.

Weight: 135 lbs. / 61.4 kgs.

Dimensions: L48" x W28" x H50 5/8"
L121.9cm x W71.1cm x H128.6cm

Features:

- Holds (38) Baby Stands (2-Riser and 3-Riser)
- Baby Stand Holders can be switched with Combo Stand Holders (see accessories)
- Jockey Box Holds (1) Half Milk Crate
- Wheels (2) 10" Swivel Casters & (2) 10" Rigid Casters
(Optional (2) 10" Swivel Casters & (4) 10" Rigid Casters)
- Foot Brake

Accessories:

- Combo Stand Holder **(CS-4)** Holds (4) Combo Stands \$ 65.00
- Combo Stand Holder **(CS-5)** Holds (5) Combo Stands \$ 65.00

Options:

- Half Milk Crate **(B-05)** \$ 20.00
- Half Milk Crate Liner **(B-06)** \$ 19.00
- Foam Filled Tires **(WA-10 FOAM CTR)** \$ 240.00
- Additional (2) 10" Pneumatic Rigid Caster Wheel **(W-10 RCX)** \$ 176.00
- Additional (2) 10" Foam Filled Tires **(WA-10 FOAM CTR)** \$ 120.00

Replacement parts:

- 10" Pneumatic Tire **(WA-10 TIRE)** \$ 24.00
- 10" Pneumatic Tube **(WA-10 TUBE)** \$ 12.00
- 10" Pneumatic Rigid Caster Wheel **(W-10 RCX)** \$ 88.00
- 10" Pneumatic Swivel Caster Wheel **(W-10 SCX)** \$ 91.00

Shipping Dimensions: L49" x W29" x H53" (175 lbs.)
L124.5cm x W73.7cm x H134.6cm (79.5 kgs.)



NOTE: Milk Crates not included

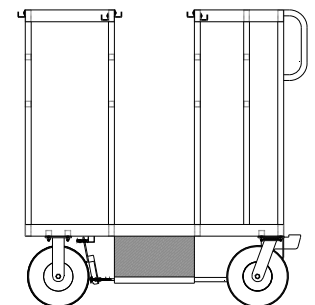
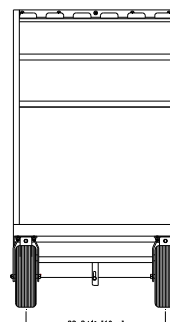
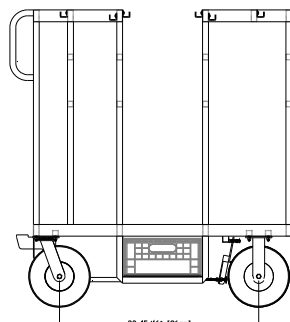
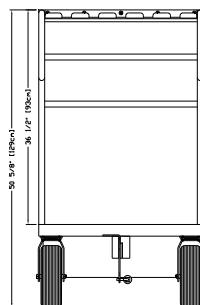
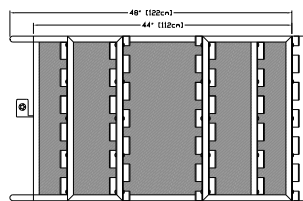
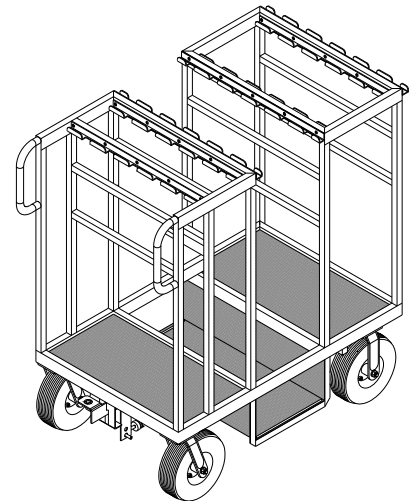



Apple Box Cart

Part No. G-10

Sale Price: \$ 1,195.00

Material: Steel

Color: Black Hammertone

Max. Capacity: 800 lbs. / 364 kgs.

Weight: 108 lbs. / 49.1 kgs.

Dimensions: L35 1/2" x W26 1/2" x H79 1/2"
L90.2cm x W67.3cm x H202cm

Features:

- Holds (16) Full, (18) Half or combination
- Wheels (2) 8" Swivel Casters with Brakes & (2) 8" Rigid Casters

Accessories:

Options:

- Foam Filled Tires (**WA-08 FOAM CTR**) \$ 208.00

Replacement parts:

- 8" Pneumatic Tire (**WA-08 TIRE**) \$ 22.00
- 8" Pneumatic Tube (**WA-08 TUBE**) \$ 11.00
- 8" Pneumatic Rigid Caster Wheel (**W-08 RCX**) \$ 80.00
- 8" Pneumatic Swivel Caster Wheel with Brake (**W-08 SCBRX**) \$ 85.00

Shipping Dimensions: L40" x W27" x H80" (123 lbs.)
L101.6cm x W68.6cm x H203.2cm (55.9 kgs.)





Head Cart

Part No. E-02

Sale Price: \$ 2,925.00

Material: Steel

Color: Black Hammertone

Max. Capacity: 1,000 lbs. / 454 kgs.

Weight: 216 lbs. / 98.2 kgs.

Dimensions: L59 1/8" x W28" x H60 1/8"
L150.2cm x W71.1cm x H152.7cm

Features:

- (2) Adjustable (Alum.) Shelves with Spring Loaded Locking Pins (L53 7/8" x W19 1/2") (L136.8cm x W49.5cm)
- Bottom Section (L54" x W19 1/2") (L137.2cm x W49.5cm)
- Outfitted with (4) Built-In Front, Rear and Side Stand Holder Threaded Rivets, accommodates up to (20) Electric Stands
- Rear Storage (L54" x W7") (L137.2cm x W17.8cm)
- Jockey Box Holds (2) Half Milk Crates
- Wheels (2) 10" Swivel Casters & (2) 10" Rigid Casters (Optional (2) 10" Swivel Casters & (4) 10" Rigid Casters)
- Foot Brake
- Pull Bar

Accessories:

- Additional (Aluminum) Adjustable Shelf (**E-02 SHELF (AL)**) \$ 480.00

Options:

- Rear Fold-Down Table (**TB-42**) \$ 428.00
- Milk Crate (**B-03**) \$ 20.00
- Half Milk Crate (**B-05**) \$ 20.00
- Full Milk Crate Liner (**B-04**) \$ 19.50
- Half Milk Crate Liner (**B-06**) \$ 19.00
- Foam Filled Tires (**WA-10 FOAM CTR**) \$ 240.00
- Additional (2) 10" Pneumatic Rigid Caster Wheel (**W-10 RCX**) \$ 176.00
- Additional (2) 10" Foam Filled Tires (**WA-10 FOAM CTR**) \$ 120.00

Replacement parts:

- 10" Pneumatic Tire (**WA-10 TIRE**) \$ 24.00
- 10" Pneumatic Tube (**WA-10 TUBE**) \$12.00
- 10" Pneumatic Rigid Caster Wheel (**W-10 RCX**) \$ 88.00
- 10" Pneumatic Swivel Caster Wheel (**W-10 SCX**) \$ 91.00

Shipping Dimensions: L60" x W29" x H61" (230 lbs.)
L155cm x W73.7cm x H152.4cm (104.6 kgs.)



NOTE: Milk Crates not included

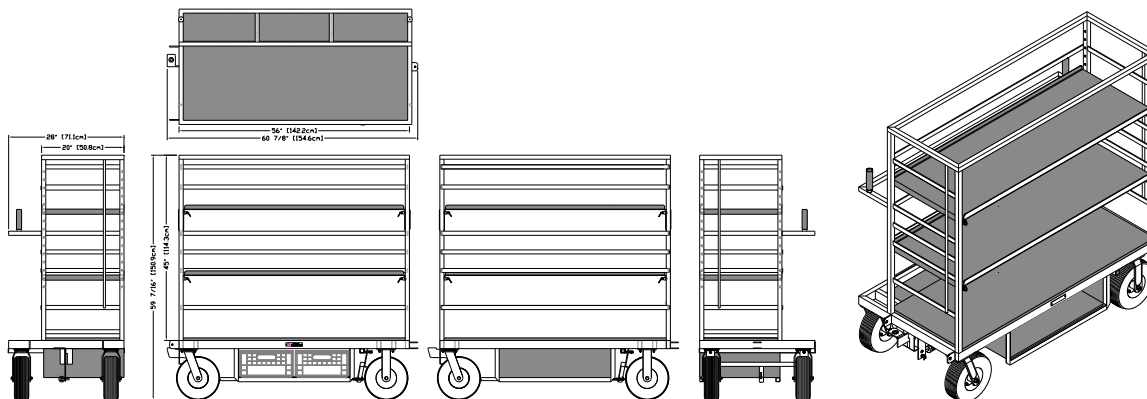



Head Cart Plus

Part No. E-02 PLUS

Sale Price: \$ 3,295.00

Material: Steel

Color: Black Hammertone

Max. Capacity: 1,000 lbs. / 454 kgs.

Weight: 248 lbs. / 112.7 kgs.

Dimensions: L65 1/4" x W28" x H60 1/4"
L165.7cm x W71.1cm x H153cm

Features:

- (2) Adjustable (Alum.) Shelves with Spring Loaded Locking Pins (L53 7/8" x W19 1/2") (L136.8cm x W49.5cm)
- Bottom Section (L54" x W19 1/2") (L137.2cm x W49.5cm)
- Rear Section Holds (5) Combo Stands and (4) Low Combo Stands
- Side Section Holds (4) Low Combo Stands or (4) Baby Stands
- (3) Large Handles Hold Stingers
- Jockey Box Holds (2) Half Milk Crates
- Wheels (2) 10" Swivel Casters & (2) 10" Rigid Casters (Optional (2) 10" Swivel Casters & (4) 10" Rigid Casters)
- Foot Brake
- Pull Bar

Accessories:

- Additional Adjustable (Alum.) Shelf with Spring Loaded Locking Pins (**E-02 SHELF (AL)**)\$ 480.00

Options:

- Rear Fold-Down Table (**TB-42**) \$ 428.00
- Milk Crate (**B-03**) \$ 20.00
- Half Milk Crate (**B-05**) \$ 20.00
- Full Milk Crate Liner (**B-04**) \$ 19.50
- Half Milk Crate Liner (**B-06**) \$ 19.00
- Foam Filled Tires (**WA-10 FOAM CTR**) \$ 240.00
- Additional (2) 10" Pneumatic Rigid Caster Wheel (**W-10 RCX**) \$ 176.00
- Additional (2) 10" Foam Filled Tires (**WA-10 FOAM CTR**) \$ 120.00

Replacement parts:

- 10" Pneumatic Tire (**WA-10 TIRE**) \$ 24.00
- 10" Pneumatic Tube (**WA-10 TUBE**) \$ 12.00
- 10" Pneumatic Rigid Caster Wheel (**W-10 RCX**) \$ 88.00
- 10" Pneumatic Swivel Caster Wheel (**W-10 SCX**) \$ 91.00

Shipping Dimensions: L66" x W29" x H61" (263 lbs.)
L167.6cm x W73.7cm x H154.9cm (119.6 kgs.)



NOTE: Milk Crates not included

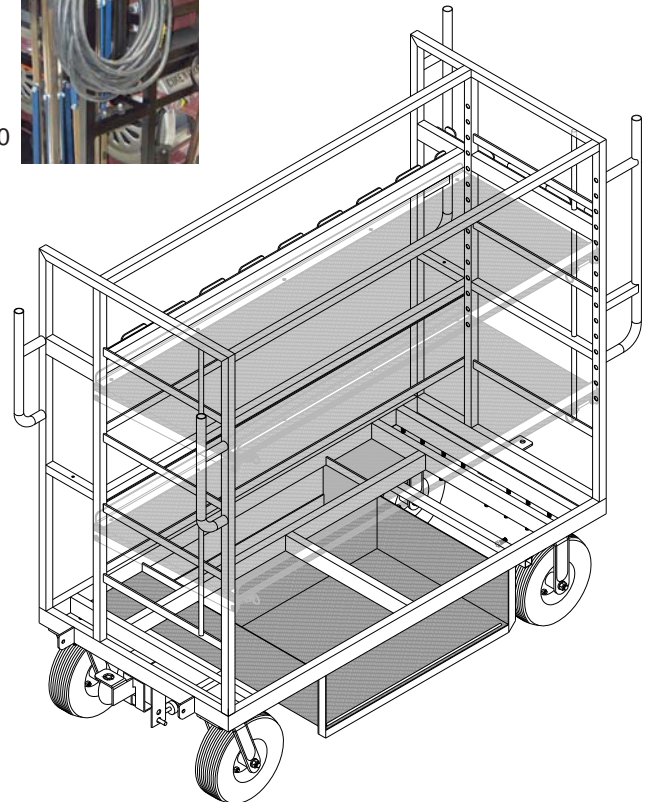



HMI Cart

Part No. E-03

Sale Price: \$ 2,975.00

Material: Steel

Color: Black Hammertone

Max. Capacity: 1,000 lbs. / 454 kgs.

Weight: 230 lbs. / 104.6 kgs.

Dimensions: L60" x W28" x H75"
L152.4cm x W71.1cm x H190.5cm

Features:

- Holds (5) Combo Stands
- (6) 16" Head Feeder Prongs
- (1) Adjustable Shelf (L40" x W27 1/2") (L101.6cm x W70cm)
- Bottom Section (L40" x W27 1/2") (L101.6cm x W70cm)
- Top Storage Pan (L40" x W26" x H5 1/2") (L101.6cm x W66cm X H14cm)
- Jockey Box Holds (2) Half Milk Crates
- Wheels (2) 10" Swivel Casters & (2) 10" Rigid Casters
(Optional (2) 10" Swivel Casters & (4) 10" Rigid Casters)
- Foot Brake
- Pull Bar
- Foam Filled Tires

Accessories:

- Additional Adjustable Shelf (**E-03 SHELF**) \$ 420.00

Options:

- Milk Crate (**B-03**) \$ 20.00
- Half Milk Crate (**B-05**) \$ 20.00
- Full Milk Crate Liner (**B-04**) \$ 19.50
- Half Milk Crate Liner (**B-06**) \$ 19.00
- Additional (2) 10" Pneumatic Rigid Caster Wheel (**W-10 RCX**) \$ 176.00
- Additional (2) 10" Foam Filled Tires (**WA-10 FOAM CTR**) \$ 120.00

Replacement parts:

- 10" Foam Filled Rigid Caster Wheel (**W-10 RCX / WA-10 FOAM CTR**) \$ 148.00
- 10" Foam Filled Swivel Caster Wheel (**W-10 SCX / WA-10 FOAM CTR**) \$ 151.00

Shipping Dimensions: L61" x W29" x H76" (245 lbs.)

L155cm x W73.7cm x H193cm (111.4 kgs.)



NOTE: Milk Crates not included

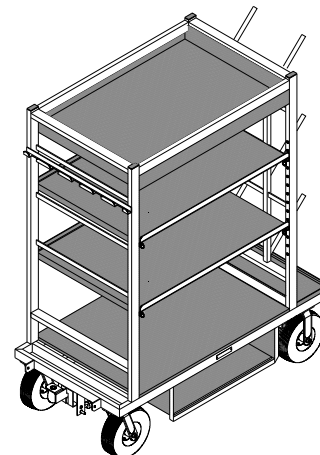
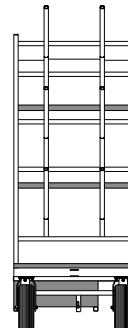
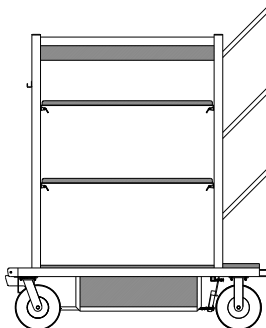
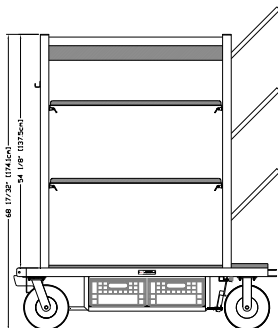
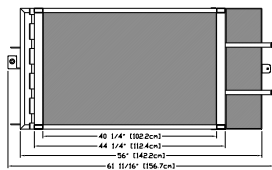



Universal Junior Cart

Part No. E-05

Sale Price: \$ 3,150.00

Material: Steel

Color: Black Hammertone

Max. Capacity: 1,000 lbs. / 454 kgs.

Weight: 280 lbs. / 127.3 kgs.

Dimensions: L60" x W28" x H68 1/2"

L152.4cm x W71.1cm x H174cm

Features:

- Holds (5) Combo Stands
- (2) Adjustable Shelf (L50 3/8" x W27 1/2") (L128cm x W70cm)
- Bottom Section (L50 1/2" x W27 1/2") (L128.3cm x W70cm)
- Jockey Box Holds (2) Half Milk Crates
- Wheels (2) 10" Swivel Casters & (2) 10" Rigid Casters
(Optional (2) 10" Swivel Casters & (4) 10" Rigid Casters)
- Foot Brake
- Pull Bar
- Foam Filled Tires

Accessories:

- Additional Adjustable Shelf (**E-05 SHELF**) \$ 595.00

Options:

- Milk Crate (**B-03**) \$ 20.00
- Half Milk Crate (**B-05**) \$ 20.00
- Full Milk Crate Liner (**B-04**) \$ 19.50
- Half Milk Crate Liner (**B-06**) \$ 19.00
- Additional (2) 10" Pneumatic Rigid Caster Wheel (**W-10 RCX**) \$ 176.00
- Additional (2) 10" Foam Filled Tires (**WA-10 FOAM CTR**) \$ 120.00

Replacement parts:

- 10" Foam Filled Rigid Caster Wheel (**W-10 RCX / WA-10 FOAM CTR**) \$ 148.00
- 10" Foam Filled Swivel Caster Wheel (**W-10 SCX / WA-10 FOAM CTR**) \$ 151.00

Shipping Dimensions: L61" x W29" x H69" (295 lbs.)

L155cm x W73.7cm x H175.3cm (134 kgs.)



NOTE: Milk Crates not included

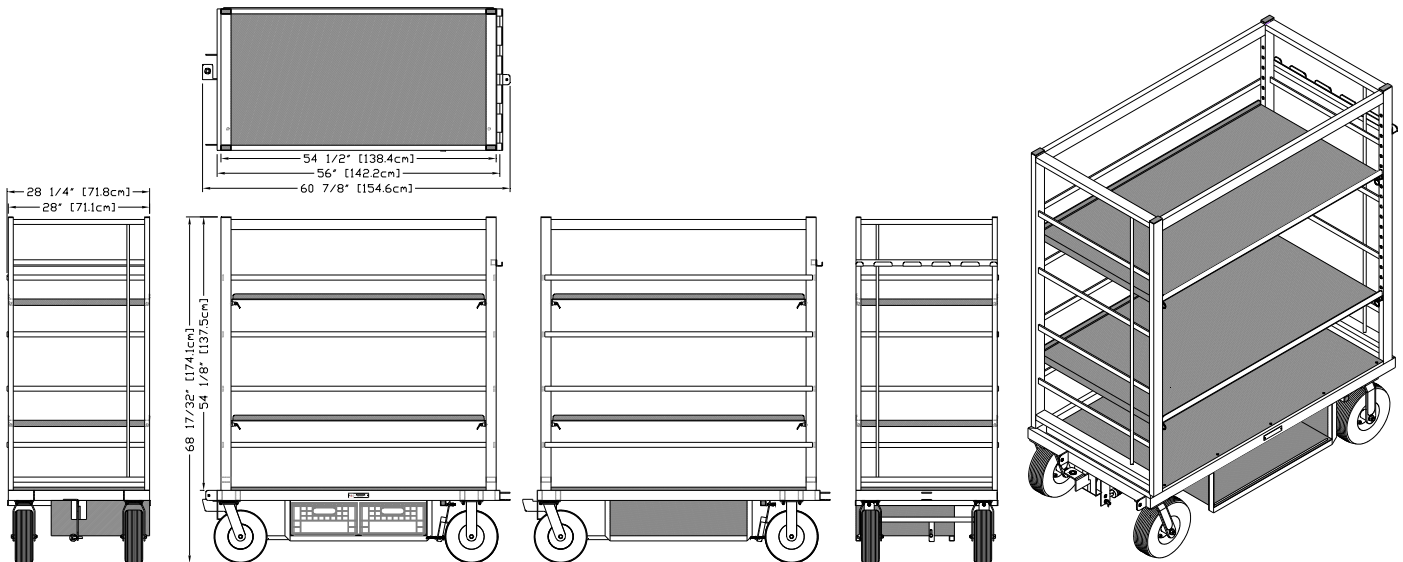



Universal Senior Cart

Part No. E-04

Sale Price: \$ 3,750.00

Material: Steel

Color: Black Hammertone

Max. Capacity: 1,000 lbs. / 454 kgs.

Weight: 365 lbs. / 165.9 kgs.

Dimensions: L63" x W31" x H74"

L160cm x W78.7cm x H188cm

Features:

- (3) Adjustable Shelves (L54 7/8" x W29 1/2") (L139.4cm x W75cm)
- (1) Stationary Shelf (L55" x W30") (L140cm x W76.2cm)
- Jockey Box Holds (2) Half Milk Crates
- (2) Horizontal E-Track Locks
- Wheels (2) 10" Swivel Casters & (2) 10" Swivel Lock Casters
- Foot Brake
- Pull Bar
- Foam Filled Tires

Accessories:

- Additional Adjustable Shelf (**E-04 SHELF**) \$ 605.00

Options:

- Milk Crate (**B-03**) \$ 20.00
- Half Milk Crate (**B-05**) \$ 20.00
- Full Milk Crate Liner (**B-04**) \$ 19.50
- Half Milk Crate Liner (**B-06**) \$ 19.00

Replacement parts:

- 10" Foam Filled Swivel Lock Caster Wheel (**W-10 SCX / WA-10 FOAM CTR & WA-10 SLOCK**) \$ 166.00
- 10" Foam Filled Swivel Caster Wheel (**W-10 SCX / WA-10 FOAM CTR**) \$ 151.00
- Swivel Lock Plunger (**WA-10 SLOCK**) \$ 15.00

Shipping Dimensions: L64" x W32" x H75" (380 lbs.)

L162.6cm x W81.3cm x H190.5cm (172.7 kgs.)



NOTE: Milk Crates not included

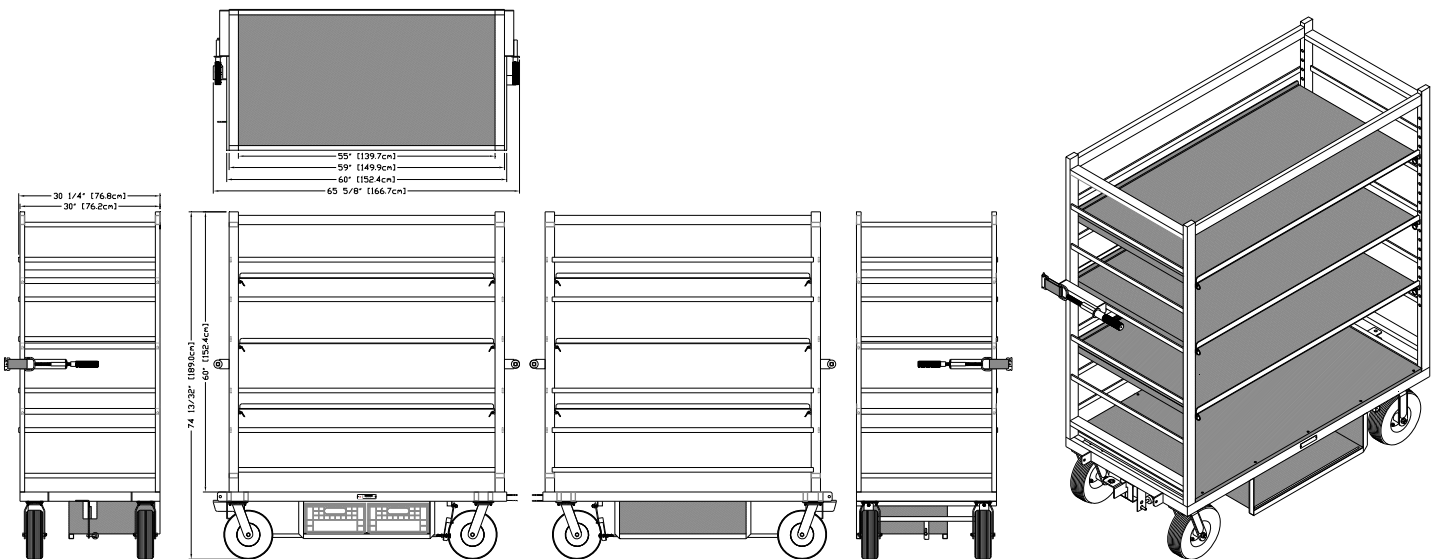



Cable Cart

Part No. GE-02

Sale Price: \$ 1,295.00

Material: Steel

Color: Black Hammertone

Max. Capacity: 1,000 lbs. / 454 kgs.

Weight: 97 lbs. / 44 kgs.

Dimensions: L42 1/2" x W28 1/2" x H45 1/2"
L108cm x W72.4cm x H116cm

Features:

- Holds Cables, Sandbags, Stands, Milk Crates
- Carriage Base D21 1/2" x W20" (D54.6cm x W50.8cm)
- (4) 10" Pneumatic Offset Wheels
- Hand Brake

Accessories:

Options:

- Foam Filled Tires (**WA-10 FOAM OS**) \$ 240.00

Replacement parts:

- 10" Pneumatic Tire (**WA-10 TIRE**) \$ 24.00
- 10" Pneumatic Tube (**WA-10 TUBE**) \$ 12.00
- 10" Pneumatic Offset Wheel (**W-10 OS34X**) \$ 65.00
- 3/4" Sealed Bearing (**WA-34 BR**) \$ 2.75 (Need (2) per Wheel)

Shipping Dimensions: L52" x W31" x H31" (107 lbs.)
L132.1cm x W78.8cm x H78.8cm (48.6 kgs.)

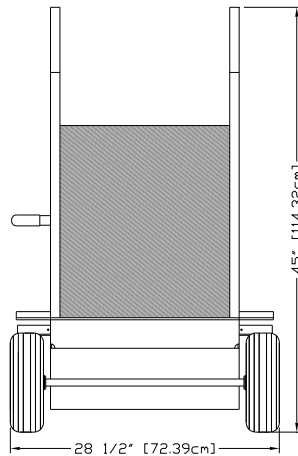
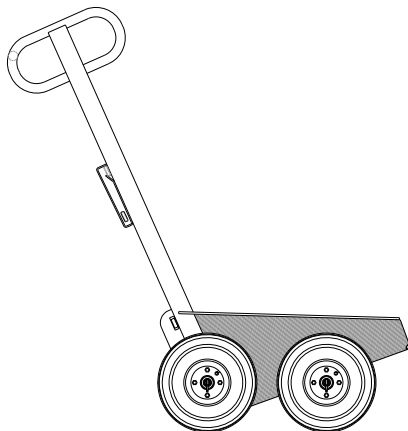
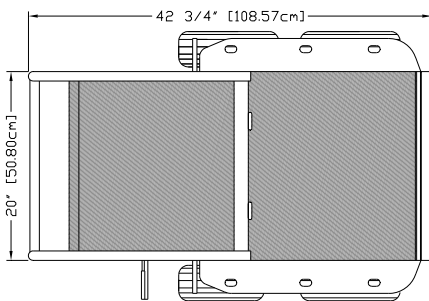



Cable Cart (Foldable)

Part No. GE-02 FD

Sale Price: \$ 1,625.00

Material: Steel

Color: Black Hammertone

Max. Capacity: 1,000 lbs. / 454 kgs.

Weight: 110 lbs. / 50 kgs.

Dimensions: L42 1/2" x W28 1/2" x H45 1/2"
L108cm x W72.4cm x H116cm
L35 15/16" x W28 1/2" x H20 1/4" (Folded)
L91.3cm x W72.4cm x H51.4cm

Features:

- Folds to a compact size (Folding mechanism uses Quick Release Aircraft Pins to lock system into place)
- Holds Cable and Sandbags
- Carriage Base (D21 1/2" x W20" / D54.6cm x W50.8cm)
- (4) 10" Pneumatic Offset Wheels
- Hand Brake

Accessories:

Options:

- Foam Filled Tires (**WA-10 FOAM OS**) \$ 240.00

Replacement parts:

- 10" Pneumatic Tire (**WA-10 TIRE**) \$ 24.00
- 10" Pneumatic Tube (**WA-10 TUBE**) \$12.00
- 10" Pneumatic Offset Wheel (**W-10 OS34X**) \$ 65.00
- 3/4" Sealed Bearing (**WA-34 BR**) \$ 2.75 (Need (2) per Wheel)

Shipping Dimensions: L30" x W22" x H38" (125 lbs.)
L76.2cm x W55.9cm x H96.5cm (56.8kgs.)

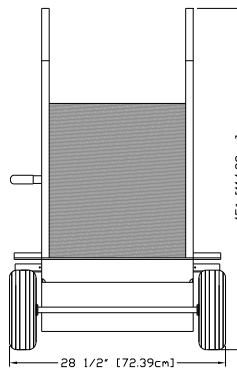
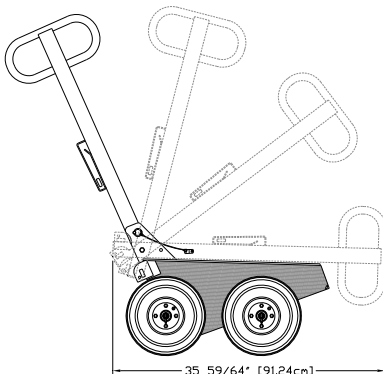
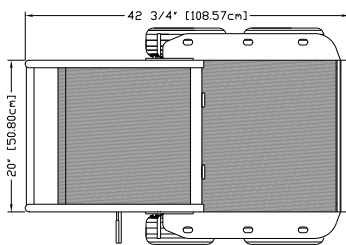



Muscle Cart

Part No. GE-01

Sale Price: \$ 1,650.00

Material: Steel

Color: Black Hammertone

Max. Capacity: 1,000 lbs. / 454 kgs.

Weight: 92 lbs. / 41.8 kgs.

Dimensions: L35 3/4" x W30 1/2" x H45 3/4"
L91.4cm x W76.2cm x H115.6cm

Features:

- Holds Cables, Sandbags, Stands, Milk Crates
- Carriage Base D22 1/2" x W20 1/2" (D57.2cm x W52.1cm)
- (2) 10" Pneumatic Swivel Caster Wheels, (2) 10" Pneumatic Offset Wheels
- Hand Brake

Accessories:

Options:

- Foam Filled Tires (**WA-10 FOAM OS**) \$ 120.00
- Foam Filled Tires (**WA-10 FOAM CTR**) \$ 120.00

Replacement parts:

- 10" Pneumatic Tire (**WA-10 TIRE**) \$ 24.00
- 10" Pneumatic Tube (**WA-10 TUBE**) \$ 12.00
- 10" Pneumatic Swivel Caster Wheel (**W-10 SCX**) \$ 91.00
- 10" Pneumatic Offset Wheel (**W-10 OS34X**) \$ 65.00
- 3/4" Sealed Bearing (**WA-34 BR**) \$ 2.75 (Need (2) per Wheel)

Shipping Dimensions: L52" x W31" x H31" (102 lbs.)
L132.1cm x W78.8cm x H78.8cm (46.4 kgs.)





Cable Distro Cart

Part No. GE-03**Sale Price:** \$ 2,250.00**Material:** Steel**Color:** Black Hammertone**Max. Capacity:** 1,000 lbs. / 454 kgs.**Weight:** 206 lbs. / 92.3 kgs.**Dimensions:** L62" x W28" x H50"

L157.5cm x W71.1cm x H127cm

Features:

- Holds Milk Crates, Cable, Sand Bags, Ballasts
- (2) Stationary Shelves (L54" x W26") (L137.2cm x W66cm)
- Jockey Box Holds (2) Half Milk Crates
- Wheels (2) 10" Swivel Casters & (2) 10" Rigid Casters
(Optional (2) 10" Swivel Casters & (4) 10" Rigid Casters)
- Foot Brake
- Pull Bar

Accessories:**Options:**

- Milk Crate **(B-03)** \$ 20.00
- Half Milk Crate **(B-05)** \$ 20.00
- Full Milk Crate Liner **(B-04)** \$ 19.50
- Half Milk Crate Liner **(B-06)** \$ 19.00
- Foam Filled Tires **(WA-10 FOAM CTR)** \$ 240.00
- Additional (2) 10" Pneumatic Rigid Caster Wheel **(W-10 RCX)** \$ 176.00
- Additional (2) 10" Foam Filled Tires **(WA-10 FOAM CTR)** \$ 120.00

Replacement parts:

- 10" Pneumatic Tire **(WA-10 TIRE)** \$ 24.00
- 10" Pneumatic Tube **(WA-10 TUBE)** \$ 12.00
- 10" Pneumatic Rigid Caster Wheel **(W-10 RCX)** \$ 88.00
- 10" Pneumatic Swivel Caster Wheel **(W-10 SCX)** \$ 91.00

Shipping Dimensions: L63" x W29" x H51" (218 lbs.)

L160cm x W73.7cm x H130cm (99 kgs.)

**NOTE: Milk Crates not included**



Whip Distro Cart

Part No. GE-08

Sale Price: \$ 2,375.00

Material: Steel

Color: Black Hammertone

Max. Capacity: 1,000 lbs. / 454 kgs.

Weight: 180 lbs. / 81.8 kgs.

Dimensions: L60" x W28" x H49 1/2"
L152.4cm x W71.1cm x H125.7cm

Features:

- Holds Cable in Figure-8 or Wrapped
- Dual Hooks Hold (1) Full Size Milk Crate
- (1) Stationary Shelf (L54" x W26") (L137.2cm x W66cm)
- Jockey Box Holds (2) Half Milk Crates
- Wheels (2) 10" Swivel Casters & (4) 10" Rigid Casters
- Foot Brake
- Pull Bar

Accessories:

- 100/60 Amp Bate Holder (**GE-08 BH**) \$ 275.00

Options:

- Milk Crate (**B-03**) \$ 20.00
- Half Milk Crate (**B-05**) \$ 20.00
- Full Milk Crate Liner (**B-04**) \$ 19.50
- Half Milk Crate Liner (**B-06**) \$ 19.00
- Foam Filled Tires (**WA-10 FOAM CTR**) \$ 360.00

Replacement parts:

- 10" Pneumatic Tire (**WA-10 TIRE**) \$ 24.00
- 10" Pneumatic Tube (**WA-10 TUBE**) \$ 12.00
- 10" Pneumatic Rigid Caster Wheel (**W-10 RCX**) \$ 88.00
- 10" Pneumatic Swivel Caster Wheel (**W-10 SCX**) \$ 91.00

Shipping Dimensions: L61" x W29" x H51" (195 lbs.)
L155cm x W73.7cm x H130cm (88.6 kgs.)



NOTE: Milk Crates not included



Stinger Cart

Part No. E-15

Sale Price: \$ 835.00

Material: Steel

Color: Black Hammertone

Max. Capacity: 500 lbs. / 227.3 kgs.

Weight: 70 lbs. / 31.8 kgs.

Dimensions: L28 1/4" x W21" x H48 3/4"
L71.8cm x W53.3cm x H123.8cm

Features:

- Holds (35) 50' Stingers
- (2) 10" Pneumatic Offset Wheels

Accessories:

Options:

- Foam Filled Tires (**WA-10 FOAM OS**) \$ 120.00

Replacement parts:

- 10" Pneumatic Tire (**WA-10 TIRE**) \$ 24.00
- 10" Pneumatic Tube (**WA-10 TUBE**) \$ 12.00
- 10" Pneumatic Offset Wheel (**W-10 OS34X**) \$ 65.00
- 3/4" Sealed Bearing (**WA-34 BR**) \$ 2.75 (Need (2) per Wheel)

Shipping Dimensions: L16" x W26" x H38" (79 lbs.)
L40.6cm x W66cm x H96.5cm (35.9 kgs.)





Cable X-Over Cart

Part No. E-13

Sale Price: \$ 1,110.00

Material: Steel

Color: Black Hammertone

Max. Capacity: 600 lbs. / 272.7 kgs.

Weight: 56 lbs. / 25.5 kgs.

Dimensions: L39 5/16" x W24 1/2" x H43 5/16"
L99.9cm x W62.2cm x H110cm



E-13 Shown with optional Folding Plate down



Features:

- Holds (12) Standard Cross-Over
- Hand Brake
- (2) 6" Balloon Swivel Caster Wheels with Brakes,
- (2) 10" Pneumatic Offset Wheels

Accessories:

Options:

- Foam Filled Tires (**WA-10 FOAM OS**) \$ 120.00
- Cable X-Over Cart (Aluminum) Folding Plate (**E-13 C**) \$ 265.00
Allows you to accomodate Milk Crates, Apple Boxes & Large Light Fixtures (ARRI 18K)

Replacement parts:

- 6" Balloon Swivel Caster Wheel with Brake (**W-06 SCBRX BLN-GR**) \$ 33.00
- 10" Pneumatic Tire (**WA-10 TIRE**) \$ 24.00
- 10" Pneumatic Tube (**WA-10 TUBE**) \$ 12.00
- 10" Pneumatic Offset Wheel (**W-10 OS34X**) \$ 65.00
- 3/4" Sealed Bearing (**WA-34 BR**) (Need (2) per Wheel)

Shipping Dimensions: L52" x W31" x H20" (62 lbs.)
L132.1cm x W78.7cm x H50.8cm (28.2 kgs.)



E-13 Shown with optional Folding Plate up



E-13 Shown with Milk Crates

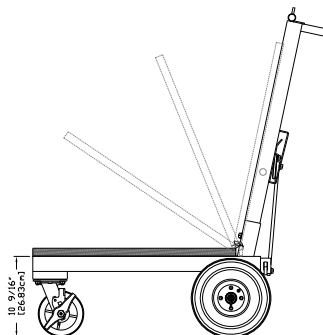
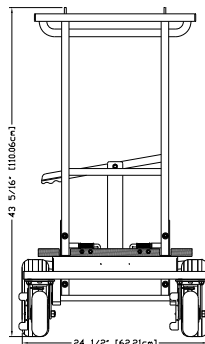
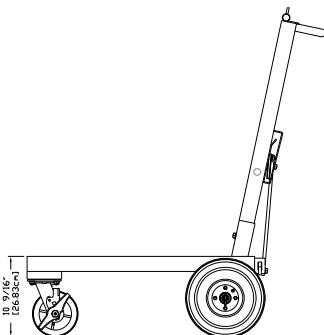
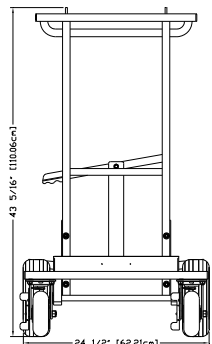
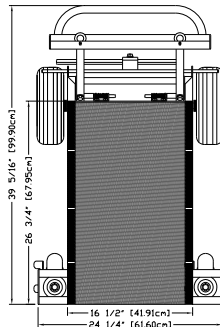
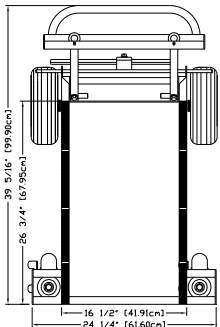

Cable X-Over Cart shown with optional (Aluminum) Folding Plate



E-13 Shown with Apple Boxes



C-Stand Cart

Part No. GE-04

Sale Price: \$ 1,075.00

Material: Steel

Color: Black Hammertone

Max. Capacity: 800 lbs. / 364 kgs.

Weight: 64 lbs. / 29.1 kgs.

Dimensions: L37 1/4" x W25" x H58 1/4"
L94.7cm x W63.5cm x H148cm

Features:

- Holds (18-20) C-Stands
- (2) 6" Balloon Swivel Caster Wheels with Brakes, (2) 10" Pneumatic Offset Wheels

Accessories:

Options:

- Foam Filled Tires (**WA-10 FOAM OS**) \$ 120.00

Replacement parts:

- 6" Balloon Swivel Caster Wheel with Brake (**W-06 SCBRX BLN-GR**) \$ 33.00
- 10" Pneumatic Tire (**WA-10 TIRE**) \$ 24.00
- 10" Pneumatic Tube (**WA-10 TUBE**) \$ 12.00
- 10" Pneumatic Offset Wheel (**W-10 OS34X**) \$ 65.00
- 3/4" Sealed Bearing (**WA-34 BR**) \$ 2.75 (Need (2) per Wheel)

Shipping Dimensions: L36" x W26" x H60" (77 lbs.)
L91.4cm x W66cm x H152.4cm (35 kgs.)





C-Stand Cart Plus

Part No. GE-04 PLUS

Sale Price: \$ 1,315.00

Material: Steel

Color: Black Hammertone

Max. Capacity: 800 lbs. / 364 kgs.

Weight: 78 lbs. / 35.5 kgs.

Dimensions: L38" x W25" x H60 3/4"
L96.5cm x W63.5cm x H154.3cm

Features:

- Holds (18-20) C-Stands
- (2) 8" Pneumatic Swivel Caster Wheels, (2) 10" Pneumatic Offset Wheels
- Hand Brake

Accessories:

Options:

- 10" Foam Filled Tires (**WA-10 FOAM OS**) \$ 120.00
- 8" Foam Filled Tires (**WA-08 FOAM CTR**) \$ 104.00

Replacement parts:

- 8" Pneumatic Tire (**WA-08 TIRE**) \$ 22.00
- 8" Pneumatic Tube (**WA-08 TUBE**) \$ 11.00
- 8" Pneumatic Swivel Caster Wheel (**W-08 SCX**) \$ 82.00
- 10" Pneumatic Tire (**WA-10 TIRE**) \$ 24.00
- 10" Pneumatic Tube (**WA-10 TUBE**) \$ 12.00
- 10" Pneumatic Offset Wheel (**W-10 OS34X**) \$ 65.00
- 3/4" Sealed Bearing (**WA-34 BR**) \$ 2.75 (Need (2) per Wheel)

Shipping Dimensions: L36" x W26" x H60" (93 lbs.)
L91.4cm x W66cm x H152.4cm (42.3 kgs.)

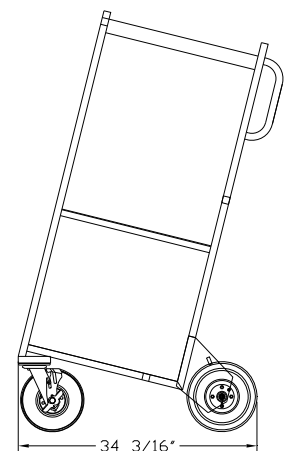
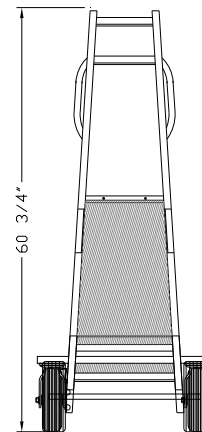
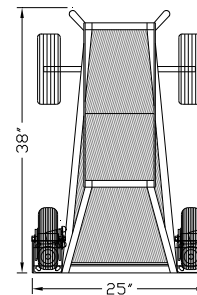



Magliner Self Stabilizing C-Stand Cart

Part No. MAG-01 SS CS-10X

Sale Price: \$ 995.00

Material: Aluminum (80%) Steel (20%)

Color: Natural Aluminum / Semi Gloss Black

Max. Capacity: 500 lbs. / 227.3 kgs.

Weight: 42 lbs. / 19 kgs.

Dimensions: D39" x W20 1/2" x H44"

L99cm x W52cm x H111.7cm

Features:

- Self Stabilizing Hand Truck
- Accommodates (10) C-Stands with Arms and Knuckles (20" & 40")
- Horizontal Loop Handle with Vinyl Sleeve
- Large 20" x 12 3/4" Base Plate
- Wheels: (2) 10" Swivel Casters & (2) 5" Rotacaster Double Row Multi-Directional Wheels

Accessories:

- Utility Box (**MAG-01 SS UB**) \$ 195.00

Options:

- Foam Filled Tires (2) (**WA-10 FOAM OS**) \$ 120.00

Replacement parts:

- 10" Pneumatic Offset Wheel with 5/8" Bearings (**W-10 OS58X**) \$ 65.00
- 10" Pneumatic Tire (**WA-10 TIRE**) \$ 24.00
- 10" Pneumatic Tube (**WA-10 TUBE**) \$ 12.00
- 5" Rotacaster Double Row Multi-Directional Wheel (**W-05 RC-DR**) \$ 45.00

Shipping Dimensions: L13" x W22" x H51" (50 lbs.) Assembled

L33cm x W55.9cm x H129.5cm (22.3 kgs.)

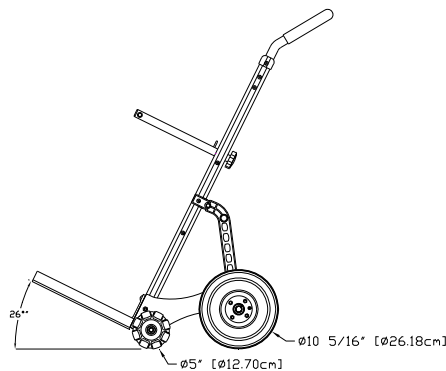
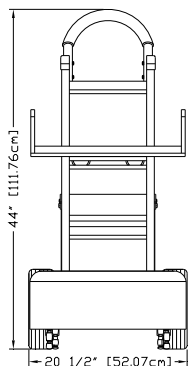
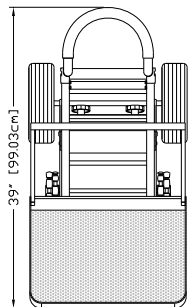



Magliner Self Stabilizing C-Stand Cart (UK)

Part No. MAG-01 SS CS-10X UK

Sale Price: \$ 1,140.00

Material: Aluminum (80%) Steel (20%)

Color: Natural Aluminum / Semi Gloss Black

Max. Capacity: 500 lbs. / 227.3 kgs.

Weight: 49 lbs. / 22.3 kgs.

Dimensions: D39" x W20 1/2" x H44"

L99cm x W52cm x H111.7cm

Features:

- Self Stabilizing Hand Truck
- Accommodates (10) C-Stands (20" & 40")
- Accommodates (10) C-Stand Arms
- Accommodates (10) C-Stands Knuckles (Optional)
- Horizontal Loop Handle with Vinyl Sleeve
- Large 20" x 14" Base Plate
- Wheels: (2) 10" Swivel Casters & (2) 5" Rotacaster Double Row Multi-Directional Wheels

Accessories:

- Utility Box (**MAG-01 SS UB**) \$ 195.00

Options:

- Foam Filled Tires (2) (**WA-10 FOAM OS**) \$ 120.00

Replacement parts:

- 10" Pneumatic Offset Wheel with 5/8" Bearings (**W-10 OS58X**) \$ 58.00
- 10" Pneumatic Tire (**WA-10 TIRE**) \$ 24.00
- 10" Pneumatic Tube (**WA-10 TUBE**) \$ 12.00
- 5" Rotacaster Double Row Multi-Directional Wheel (**W-05 RC-DR**) \$ 45.00

Shipping Dimensions: D16" x W22" x H51" (58 lbs.) Assembled

L40.6cm x W55.9cm x H129.5cm (26.4 kgs.)



Utility Box (**MAG-01 SS UB**)
(D8" x W14" x H6" / D20.3cm x W35.6cm x H15.2cm)

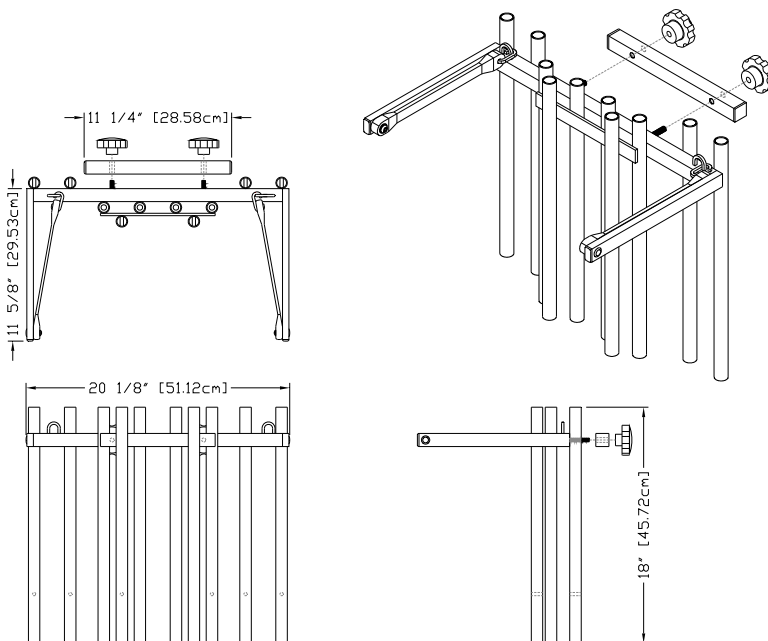



C-Stand/Hi-Roller Utility Cart

Part No. GE-13

Sale Price: \$ 1,915.00

Material: Steel

Color: Black Hammertone

Max. Capacity: 800 lbs. / 364 kgs.

Weight: 88 lbs. / 40 kgs.

Dimensions: L34 1/2" x W24 1/2" x H57 3/4"
L87.6cm x W62.2cm x H146.7cm

Features:

- Holds (16) C-Stands
- Holds (2) Hi-Roller Stands or (2) Combo Stands
- Holds (2) Milk Crates
- Bottom Pan holds Sandbags (L18 3/4 x W13 3/4") (L47.6cm x W34.9cm)
- Top Tray (22" x W13 3/8") (L55.9cm x W34cm)
- (2) 6" Balloon Swivel Caster Wheels with Brakes, (2) 10" Pneumatic Offset Wheels

Accessories:

Options:

- Foam Filled Tires **(WA-10 FOAM OS)** \$ 120.00

Replacement parts:

- 6" Balloon Swivel Caster Wheel with Brake **(W-06 SCBRX BLN-GR)** \$ 33.00
- 10" Pneumatic Tire **(WA-10 TIRE)** \$ 24.00
- 10" Pneumatic Tube **(WA-10 TUBE)** \$ 12.00
- 10" Pneumatic Offset Wheel **(W-10 OS34X)** \$ 65.00
- 3/4" Sealed Bearing **(WA-34 BR)** \$ 2.75 (Need (2) per Wheel)

Shipping Dimensions: L36" x W26" x H60" (103 lbs.)
L91.4cm x W66cm x H152.4cm (46.9 kgs.)



NOTE: Milk Crates not included





C-Stand/Hi-Roller Utility Cart Plus

Part No. GE-13 PLUS

Sale Price: \$ 2,635.00

Material: Steel

Color: Black Hammertone

Max. Capacity: 800 lbs. / 364 kgs.

Weight: 120 lbs. / 54.6 kgs.

Dimensions: L35" x W24 3/4" x H58 3/8"
L88.9cm x W62.9cm x H148.3cm

Features:

- Holds (19) C-Stands
- Holds (2) Hi-Roller Stands or (3) Low Combo Stands (Rear Section)
- Holds (2) Combo Stands or (2) Low Combo Stands (Front Section)
- Holds (2) Milk Crates
- Built-in Utility Boxes (2) D8" x W13 1/4" x H4" (D20.3cm x W33.7cm x H10.2cm)
- Bottom Pan holds Sandbags (L19 3/4 x W13 3/4" x H3") (L47.6cm x W34.9cm x H7.6cm)
- Top Tray (26" x W13 3/8") (L66cm x W34cm)
- Hand Brake
- (2) 8" Pneumatic Swivel Caster Wheels, (2) 10" Pneumatic Offset Wheels

Accessories:

Options:

- Full Milk Crate (**B-05**) \$ 20.00
- Foam Filled Tires (**WA-10 FOAM OS**) \$ 120.00
- Foam Filled Tires (**WA-08 FOAM CTR**) \$ 104.00

Replacement parts:

- 8" Pneumatic Swivel Caster Wheels (**W-08 SCX**) \$ 82.00
- 8" Pneumatic Tire (**WA-08 TIRE**) \$ 22.00
- 8" Pneumatic Tube (**WA-8 TUBE**) \$ 11.00
- 10" Pneumatic Offset Wheel (**W-10 OS34X**) \$ 65.00
- 10" Pneumatic Tire (**WA-10 TIRE**) \$ 24.00
- 10" Pneumatic Tube (**WA-10 TUBE**) \$ 12.00
- 3/4" Sealed Bearing (**WA-34 BR**) \$ 2.75 (Need (2) per Wheel)

Shipping Dimensions: L36" x W26" x H60" (135 lbs.)
L91.4cm x W66cm x H152.4cm (61.4 kgs.)



NOTE: Milk Crates not included

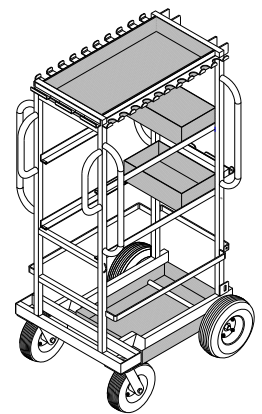
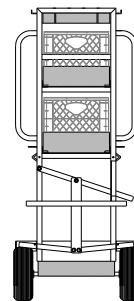
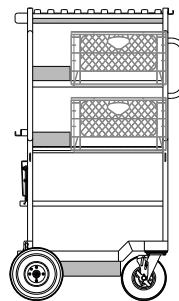
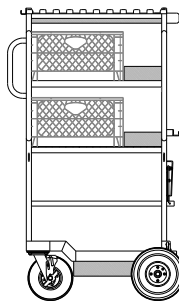
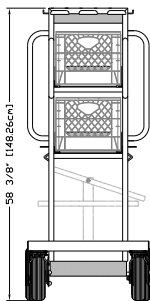
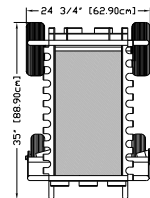



Super Duz-All Cart

Part No. G-02

Sale Price: \$ 3,595.00

Material: Steel

Color: Black Hammertone

Max. Capacity: 1,000 lbs. / 454 kgs.

Weight: 305 lbs. / 138.6 kgs.

Dimensions: L72" x W28" x H67 1/2" (With Net Basket)

L182.9cm x W71.1cm x H171.5cm

L60" x W28" x H67 1/2" (Without Net Basket)

L152.4cm x W71.1cm x H171.5cm

Features:

- (1) Adjustable Shelf (L40 1/2" x W19 3/4") (L102.9cm x W50.2cm)
- (2) Stationary Shelves (L42" x W17.75") (L106.7cm x W45.1cm)
- C-Stand Brackets Hold (18) C-Stands
- (2) Telescopic Pull-Out Ladder Holders
- Detachable 24" x 36" (61cm x 91.4cm) Net Basket (Triple)
- Front Storage Pan (L13 1/2" x W18") (L34.3cm x W45.7cm)
- Rear 4 x 4 Rack Holds 15+ Flags (L54" x W7") (L137.2cm x W17.8cm)
- Jockey Box Holds (2) Half Milk Crates
- Wheels (2) 10" Swivel Casters & (2) 10" Rigid Casters
(Optional (2) 10" Swivel Casters & (4) 10" Rigid Casters)
- Foot Brake
- Pull Bar

Accessories:

- Additional Adjustable Shelf (**G-02 SHELF**) \$ 135.00

Options:

- Net Basket Wheels (**W-03 SCBRX (2) & W-03 SCX (2)**) \$ 100.00
- Milk Crate (**B-03**) \$ 20.00
- Half Milk Crate (**B-05**) \$ 20.00
- Full Milk Crate Liner (**B-04**) \$ 19.50
- Half Milk Crate Liner (**B-06**) \$ 19.00
- Foam Filled Tires (**WA-10 FOAM CTR**) \$ 240.00
- Additional (2) 10" Pneumatic Rigid Caster Wheel (**W-10 RCX**) \$ 176.00
- Additional (2) 10" Foam Filled Tires (**WA-10 FOAM CTR**) \$ 120.00

Replacement parts:

- 10" Pneumatic Tire (**WA-10 TIRE**) \$ 24.00
- 10" Pneumatic Tube (**WA-10 TUBE**) \$ 12.00
- 10" Pneumatic Rigid Caster Wheel (**W-10 RCX**) \$ 88.00
- 10" Pneumatic Swivel Caster Wheel (**W-10 SCX**) \$ 91.00

Shipping Dimensions: L63" x W29" x H68" (324 lbs.)

L160cm x W73.7cm x H172.7cm (147.3 kgs.)



NOTE: Milk Crates not included



Speed Rail Cart

Part No. G-03

Sale Price: \$ 3,475.00

Material: Steel

Color: Black Hammertone

Max. Capacity: 1,000 lbs. / 454 kgs.

Weight: 316 lbs. / 143.6 kgs.

Dimensions: L64 5/8" x W28 1/2" x H57"

L164.2cm x W72.4cm x H144.8cm

Features:

- Accommodates (12) pieces of each: 12", 18", x 24", 30", 36" and 40" Speed Rail Pipe
- Accommodates (40) pieces of 48" Speed Rail Pipe
- (7) Sliding Milk Crate Compartments
- Top Work Tray (L42" x W18" x H2") (L106.7cm x W45.7cm, H5cm)
- Rear Storage Area (L42" x W5" x H38 1/2") (L106.7cm x W12.7cm x H97.8cm)
- (3) Drawers (D17" x W27 1/4" x H3") (D43.2cm x W69.2cm x H7.6cm)
- Pipe Holder with locking knob to assist in cutting
- Jockey Box Holds (2) Half Milk Crates
- Wheels (2) 10" Swivel Casters & (2) 10" Rigid Casters
(Optional (2) 10" Swivel Casters & (4) 10" Rigid Casters)
- Foot Brake
- Pull Bar
- (2) Locking Bars

Accessories:

- Rear Fold-Down Table (**TB-42**) \$ 428.00
- Pull-out Work Board D19" x W27 1/4" x H3/4" (D48.3cm x W69.2cm x H1.9cm)
(**DRAWER-501 B**) \$ 115.00

Options:

- Milk Crate (**B-03**) \$ 20.00
- Half Milk Crate (**B-05**) \$ 20.00
- Full Milk Crate Liner (**B-04**) \$ 19.50
- Half Milk Crate Liner (**B-06**) \$ 19.00
- Foam Filled Tires (**WA-10 FOAM CTR**) \$ 240.00
- Additional (2) 10" Pneumatic Rigid Caster Wheel (**W-10 RCX**) \$ 176.00
- Additional (2) 10" Foam Filled Tires (**WA-10 FOAM CTR**) \$ 120.00

Replacement parts:

- 10" Pneumatic Tire (**WA-10 TIRE**) \$ 24.00
- 10" Pneumatic Tube (**WA-10 TUBE**) \$ 12.00
- 10" Pneumatic Rigid Caster Wheel (**W-10 RCX**) \$ 88.00
- 10" Pneumatic Swivel Caster Wheel (**W-10 SCX**) \$ 91.00
- Full Size Aluminum Set Box drawer (**DRAWER-01 AL**) \$ 255.00

Shipping Dimensions: L65" x W29" x H58" (331 lbs.)

L165.1cm x W73.7cm x H147.3cm (150.5 kgs.)



NOTE: Milk Crates not included



Grande 4 X 4 Cart

Part No. G-01

Sale Price: \$ 2,375.00

Material: Steel

Color: Black Hammertone

Max. Capacity: 1,000 lbs. / 454 kgs.

Weight: 220 lbs. / 100 kgs.

Dimensions: L60" x W28" x H66 1/2"

L152.4cm x W71.1cm x H168.1cm

Features:

- Holds 42+ Flags, (2) 42" x 42" Reflectors & (10) Cutters
- Holds (5) Combo Stands
- Top Gel Storage Pan (L50" x W28" x H2") (L127cm x W71.1cm x H5cm)
- Jockey Box Holds (2) Half Milk Crates
- Wheels (2) 10" Swivel Casters & (2) 10" Rigid Casters
(Optional (2) 10" Swivel Casters & (4) 10" Rigid Casters)
- Foot Brake
- Pull Bar

Accessories:

- Gel Holder Detachable Rack (Holds 16 gels) **(GEL G-01)** \$ 425.00
- Net Basket 24" x 36" (61cm x 92cm) (Triple) **(B-02T)** \$ 720.00
- Net Basket Mobile 24" x 36" (61cm x 92cm) (Triple) **(B-02T MOB)** \$ 850.00
- Net Basket 24" x 36" (61cm x 92cm) (Double) **(B-02D)** \$ 575.00
- Net Basket 18" x 24" (46cm x 61cm) (Double) **(B-01D)** \$ 515.00

Options:

- Half Milk Crate **(B-05)** \$ 20.00
- Half Milk Crate Liner **(B-06)** \$ 19.00
- Foam Filled Tires **(WA-10 FOAM CTR)** \$ 240.00
- Additional (2) 10" Pneumatic Rigid Caster Wheel **(W-10 RCX)** \$ 176.00
- Additional (2) 10" Foam Filled Tires **(WA-10 FOAM CTR)** \$ 120.00

Replacement parts:

- 10" Pneumatic Tire **(WA-10 TIRE)** \$ 24.00
- 10" Pneumatic Tube **(WA-10 TUBE)** \$ 12.00
- 10" Pneumatic Rigid Caster Wheel **(W-10 RCX)** \$ 88.00
- 10" Pneumatic Swivel Caster Wheel **(W-10 SCX)** \$ 91.00

Shipping Dimensions: L60" x W29" x H67" (230 lbs.)

L152.4cm x W73.7cm x H170.2cm (104.6 kgs.)



NOTE: Milk Crates not included





4 X 4 Coaster Senior Cart

Part No. G-12

Sale Price: \$ 1,650.00

Material: Steel

Color: Black Hammertone

Max. Capacity: 800 lbs. / 364 kgs.

Weight: 90 lbs. / 40.9 kgs.

Dimensions: L55 3/4" x W21 1/4" x H43 1/8"
L141.6cm x W54cm x H109.5cm

Features:

- Fits easily into van or small truck
- Holds (36) 4 x 4 Flags
- Door Swing Bracket allows you to load from front of cart
- Wheels (2) 8" Swivel Casters with Brake & (2) 8" Rigid Casters

Accessories:

- Gel Holder Detachable Rack (Holds 16 gels) **(GEL G-01)** \$ 425.00
- Net Basket 24" x 36" (61cm x 92cm) (Triple) **(B-02T)** \$ 720.00
- Net Basket Mobile 24" x 36" (61cm x 92cm) (Triple) **(B-02T MOB)** \$ 850.00
- Net Basket 24" x 36" (61cm x 92cm) (Double) **(B-02D)** \$ 575.00
- Net Basket 18" x 24" (46cm x 61cm) (Double) **(B-01D)** \$ 515.00

Options:

- Foam Filled Tires **(WA-08 FOAM CTR)** \$ 208.00

Replacement parts:

- 8" Pneumatic Tire **(WA-08 TIRE)** \$ 22.00
- 8" Pneumatic Tube **(WA-08 TUBE)** \$ 11.00
- 8" Pneumatic Swivel Caster Wheel **(W-08 SCBRX)** \$ 85.00
- 8" Pneumatic Rigid Caster Wheel **(W-08 RCX)** \$ 80.00

Shipping Dimensions: L56" x W22" x H49" (120 lbs.)
L142.2cm x W55.9cm x H124.5cm (54.5 kgs.)

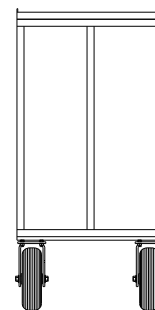
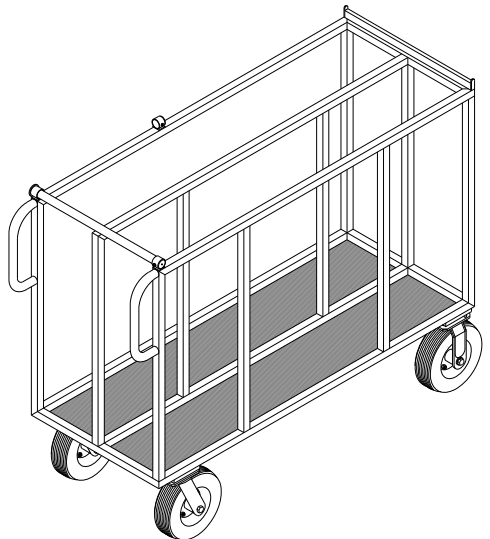
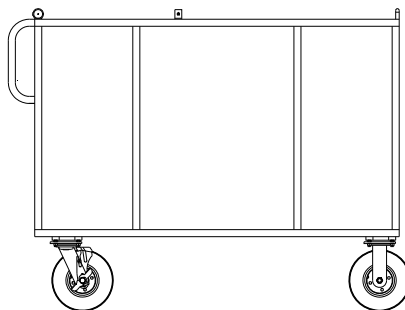
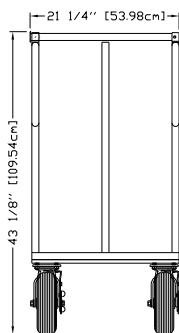
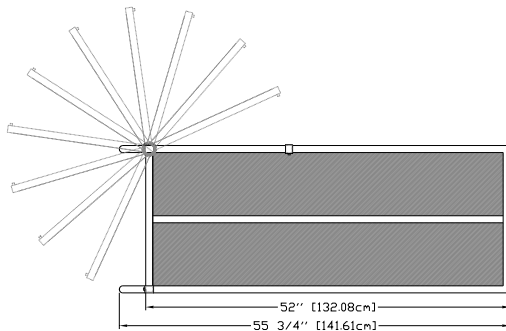



4 X 4 Coaster Senior Cart Plus

Part No. G-12 10

Sale Price: \$ 1,995.00

Material: Steel

Color: Black Hammertone

Max. Capacity: 1,000 lbs. / 364 kgs.

Weight: 120 lbs. / 54.5 kgs.

Dimensions: L55 3/4" x W21 1/4" x H44 7/8"
L141.6cm x W54cm x H114cm



Features:

- Fits easily into van or small truck
- Holds (36) 4 x 4 Flags
- Jockey Box Holds (1) Half Milk Crate
- Door Swing Bracket allows you to load from front of cart
- Wheels (2) 10" Swivel Casters & (2) 10" Rigid Casters
- Foot Brake

Accessories:

- Gel Holder Detachable Rack (Holds 16 gels) **(GEL G-01)** \$ 425.00
- Net Basket 24" x 36" (61cm x 92cm) (Triple) **(B-02T)** \$ 720.00
- Net Basket Mobile 24" x 36" (61cm x 92cm) (Triple) **(B-02T MOB)** \$ 850.00
- Net Basket 24" x 36" (61cm x 92cm) (Double) **(B-02D)** \$ 575.00
- Net Basket 18" x 24" (46cm x 61cm) (Double) **(B-01D)** \$ 515.00

Options:

- Foam Filled Tires **(WA-10 FOAM CTR)** \$ 240.00
- Half Milk Crate **(B-05)** \$ 20.00

Replacement parts:

- 10" Pneumatic Tire **(WA-10 TIRE)** \$ 24.00
- 10" Pneumatic Tube **(WA-10 TUBE)** \$12.00
- 10" Pneumatic Rigid Caster Wheel **(W-10 RCX)** \$ 88.00
- 10" Pneumatic Swivel Caster Wheel **(W-10 SCX)** \$ 91.00

Shipping Dimensions: L56" x W22" x H50" (150 lbs.) Includes Pallet
L142.2cm x W55.9cm x H127cm (68.2 kgs.)

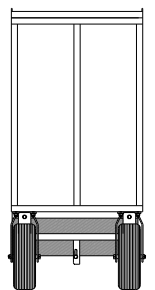
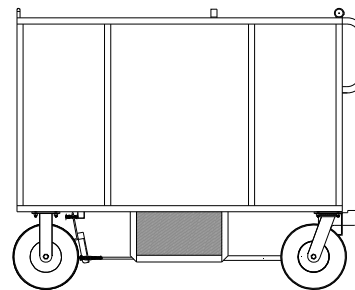
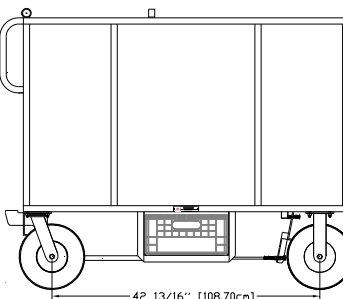
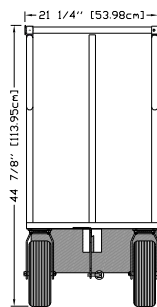
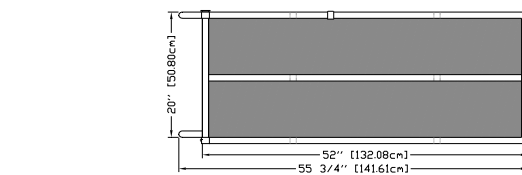
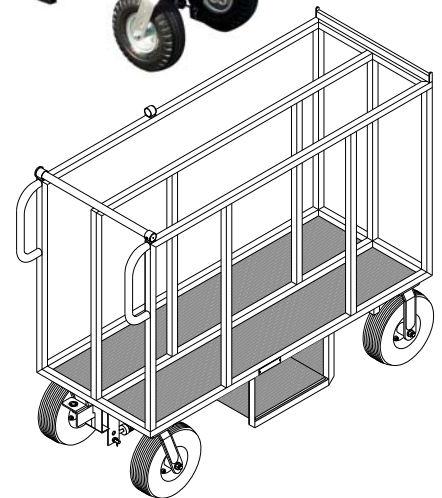



4 X 4 Coaster Junior Cart

Part No. G-11

Sale Price: \$ 1,295.00

Material: Steel

Color: Black Hammertone

Max. Capacity: 700 lbs. / 318 kgs.

Weight: 60 lbs. / 27.3 kgs.

Dimensions: L52 1/4" x W22 1/2" x H39 3/4"
L132.7cm x W57.2cm x H101cm

Features:

- Fits easily into van or small truck
- Holds (24) 4 x 4 Flags
- Door Swing Bracket allows you to load from front of cart
- Wheels (2) 5" Thermal Swivel Casters with Brake & (2) 10" Pneumatic Offset Wheels

Accessories:

- Gel Holder Detachable Rack (Holds 16 gels) **(GEL G-01)** \$ 425.00
- Net Basket 24" x 36" (61cm x 92cm) (Triple) **(B-02T)** \$ 720.00
- Net Basket Mobile 24" x 36" (61cm x 92cm) (Triple) **(B-02T MOB)** \$ 850.00
- Net Basket 24" x 36" (61cm x 92cm) (Double) **(B-02D)** \$ 575.00
- Net Basket 18" x 24" (46cm x 61cm) (Double) **(B-01D)** \$ 515.0

Options:

- Foam Filled Tires **(WA-10 FOAM OS)** \$ 120.00

Replacement parts:

- 5" Thermal Swivel Caster with Brake **(W-05 SCBRX)** \$ 28.00
- 10" Pneumatic Tire **(WA-10 TIRE)** \$ 24.00
- 10" Pneumatic Tube **(WA-10 TUBE)** \$ 12.00
- 10" Pneumatic Offset Wheel **(W-10 OS34X)** \$ 65.00
- 3/4" Sealed Bearing **(WA-34 BR)** \$ 2.75 (Need (2) per Wheel)

Shipping Dimensions: L53" x W23" x H40" (80 lbs.)

L134.7cm x W58.4cm x H101.6cm (36.4 kgs.)

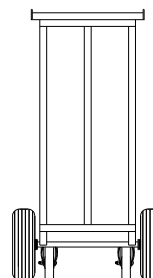
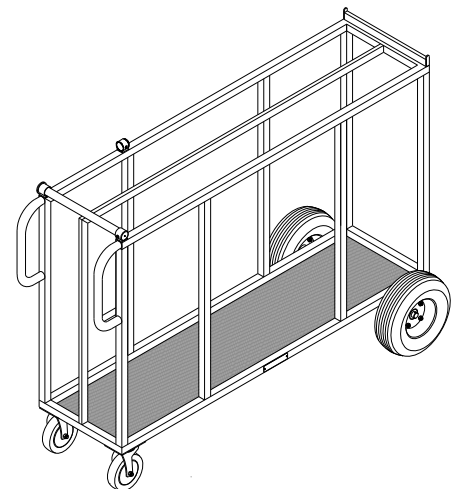
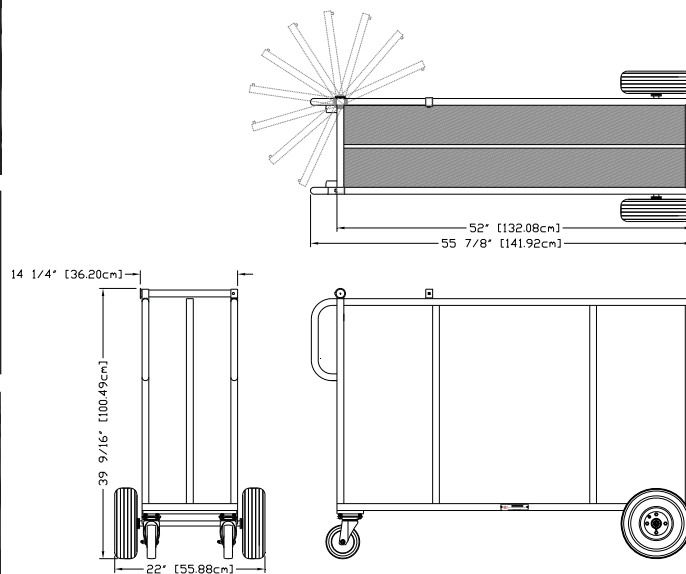



Grip Senior Cart

Part No. G-04

Sale Price: \$ 4,325.00

Material: Steel

Color: Black Hammertone

Max. Capacity: 1,000 lbs. / 454 kgs.

Weight: 271 lbs. / 123.2 kgs.

Dimensions: L70 1/2" x W29" x H65 1/4" (With Net Basket)

L179cm x W73.7cm x H165.7cm

L56 1/2" x W29" x H65 1/4" (Without Net Basket)

L143.5cm x W73.7cm x H165.7cm

Features:

- Holds (22) C-Stands (Stacking Heads not required)
- Holds (14) Full Apple Boxes or (9) Milk Crates or combination
- Holds Sandbags
- Rear Storage Area (L28" x W24" x H32") (L71.1cm x W61cm x H81.3cm)
- Front Storage Area (L20" x W13 1/2" x H37") (L71.1cm x W34.3cm x H94cm)
- Flag Area holds (5) 24" x 18" (61cm x 46cm) Flags
- Top Storage Pan (L15" x W20" x H2") (L38.1cm x W50.8cm x H5cm)
- Detachable 24" x 36" (61cm x 91.4cm) Net Basket (Triple)
- Detachable Wedge Holder
- Detachable Wedge/Cup Block Holder
- Jockey Box (D18" x W16 1/2" x H7") (L45.7cm x W41.9cm x H17.8cm)
- Front Drawer with Nail and Spraycan Compartments (D22" x W13" x H8") (D55.9cm x W33cm x H20.3cm)
- Rear Drawer (D24" x W23 1/4" x H8") (D61cm x W59.1cm x H20.3cm)
- (2) 10" Foam Filled Swivel Caster Wheels & (2) 16" Foam Filled Cable Crawler Wheels
- Hand Brake
- Pull Bar

Accessories:

Options:

- Net Basket Wheels (**W-03 SCBRX (2) & W-03 SCX (2)**) \$ 100.00
- Milk Crate (**B-03**) \$ 20.00
- Half Milk Crate (**B-05**) \$ 20.00
- Full Milk Crate Liner (**B-04**) \$ 19.50
- Half Milk Crate Liner (**B-06**) \$ 19.00

Replacement parts:

- Grip Cart Large Drawer (**DRAWER-05**) \$ 205.00
- Grip Cart Drawer w/ Dividers (**DRAWER-04**) \$ 230.00
- Cup Block/Wedge Holder (**GA-01**) \$ 280.00
- Wedge Holder (**GA-02**) \$ 210.00
- 10" Foam Filled Swivel Caster Wheel (**W-10 SCX / WA-10 FOAM CTR**) \$ 151.00
- 16" Foam Filled 16" Cable Crawler Wheel with 3/4" Bearings (**W-16 CC34X / WA-16 FOAM**) \$ 215.00

Shipping Dimensions: L60" x W29" x H68" (250 lbs.) & L29" x W17" x H34" (36 lbs.)

L152.4cm x W73.7cm x H172.7cm (113.6 kgs.) &

L73.7cm x W43.2cm x H86.4cm (16.4 kgs.)





Grip Junior Cart

Part No. G-05

Sale Price: \$ 2,975.00

Material: Steel

Color: Black Hammertone

Max. Capacity: 700 lbs. / 318 kgs.

Weight: 160 lbs. / 72.7 kgs.

Dimensions: L45 1/2" x W28" x H67" (With Net Basket)

L115.6cm x W71.1cm x H170.2cm

L38" x W28" x H67" (Without Net Basket)

L96.5cm x W71.7cm x H170.2cm

Features:

- Holds (9) C-Stands
- Holds (5) Electric Baby Stands
- Holds (4) Full Apple Boxes or (3) Milk Crates or combination
- Holds Sandbags
- Top Storage Pan (L15" x W20" x H2") (L38.1cm x W50.8cm x H5cm)
- Belly Compartment (L22 3/4" x W18") (L57.8cm x W45.7cm)
- Detachable 24" x 36" (61cm x 91.4cm) Net Basket (Triple)
- Detachable Wedge/Cup Block Holder
- Drawer with Nail and Spraycan Compartments (D22" x W13" x H8") (D55.9cm x W33cm x H20.3cm)
- Wheels (2) 5" Thermal Swivel Casters with Brake & (2) 20" Foam Filled Wheels
- Hand Brake

Accessories:

- Quad Rear Wheel Kit (**GE-07 F KIT**) \$ 565.00 (Includes (2) Extension Axles & (2) additional 20" Foam Filled Wheels)

Options:

- Net Basket Wheels (**W-03 SBRX (2) & W-03 SCX (2)**) \$ 100.00
- Milk Crate (**B-03**) \$ 20.00
- Half Milk Crate (**B-05**) \$ 20.00
- Full Milk Crate Liner (**B-04**) \$ 19.50
- Half Milk Crate Liner (**B-06**) \$ 19.00

Replacement parts:

- 5" Thermal Swivel Caster with Brake (**W-05 SCBRX**) \$ 28.00
- 20" Foam Filled 20" Wheel (**W-20 58X / WA-20 FOAM**) \$ 195.00

Shipping Dimensions: L68" x W29" x H45" (185 lbs.) w/Pallet &

L29" x W17" x H34" (36 lbs.)

L172.7cm x W73.7cm x H114.3cm (84.1 kgs.) w/Pallet

L73.7cm x W43.2cm x H86.4cm (16.4 kgs.)

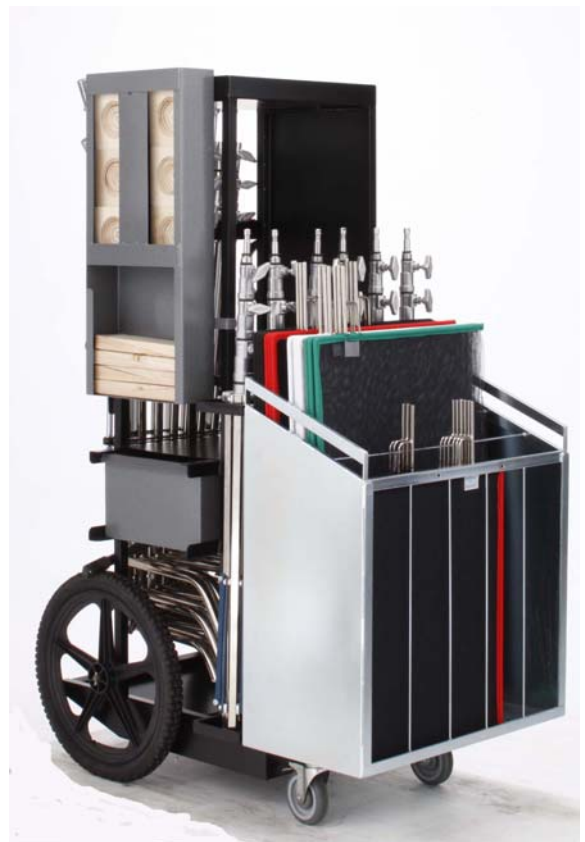



EZ-Load Grip/Electric Cart

Part No. GE-07

Sale Price: \$ 2,755.00

Material: Steel

Color: Black Hammertone

Max. Capacity: 700 lbs. / 318 kgs.

Weight: 124 lbs. / 56.4 kgs.

Dimensions: L40 1/2" x W28" x H60" (With Net Basket)

L102.9cm x W71.1cm x H152.4cm

L36 1/2" x W28" x H60" (Without Net Basket)

L92.7cm" x W71.7cm x H152.4cm

Features:

- Self Locking System holds down Stands & Milk Crates when cart is laid down.
- Holds (8) C-Stands
- Holds (2) Combo Stands
- Holds (5) Electric Baby Stands
- (3) Sliding Milk Crate Compartments
- Holds Sandbags
- (2) Telescopic Pull-Out Ladder Holders
- Top Storage Pan (Holds (1) Milk Crate) (L15" x W20" x H2") (L38.1cm x W50.8cm x H5cm)
- Belly Compartment (L22 3/4" x W18") (L57.8cm x W45.7cm)
- Detachable 24" x 36" (61cm x 91.4cm) Net Basket (Double)
- Wheels (2) 5" Thermal Swivel Casters with Brake & (2) 20" Foam Filled Wheels
- Hand Brake

Accessories:

- Quad Rear Wheel Kit (**GE-07 F KIT**) \$ 565.00 (Includes (2) Extension Axles & (2) additional 20" Foam Filled Wheels)

Options:

- Milk Crate (**B-03**) \$ 20.00
- Half Milk Crate (**B-05**) \$ 20.00
- Full Milk Crate Liner (**B-04**) \$ 19.50
- Half Milk Crate Liner (**B-06**) \$ 19.00

Replacement parts:

- 5" Thermal Swivel Caster with Brake (**W-05 SCBRX**) \$ 28.00
- 20" Foam Filled Wheel (**W-20 58X / WA-20 FOAM**) \$ 195.00

Shipping Dimensions: L62" x W27" x H43" (175 lbs.) w/Pallet & L29" x W13" x H34" (27 lbs.)

L157.5cm x W68.6cm x H109.2cm (79.6 kgs.) w/pallet & L73.7cm x W33cm x H86.4cm (12.3 kgs.)



NOTE: Milk Crates not included



Utility Plywood / Track Cart

Part No. G-07

Sale Price: \$ 2,395.00

Material: Steel

Color: Black Hammertone

Max. Capacity: 1,000 lbs. / 454 kgs.

Weight: 195 lbs. / 88.6 kgs.

Dimensions: L51 1/8" x W28 1/4" x H67 1/4"

L129.9cm x W71.8cm x H170.8cm

Features:

- Holds (8) Pieces of Track and 4' x 8' Plywood
- Plywood Holders (Adjustable)
- Detachable Top Shelf Holds (2) Milk Crates
- Base Holds (3) Milk Crates
- Jockey Box Holds (2) Half Milk Crates
- Vertical Posts and Top Shelf are Removable for Transportation
- Wheels (2) 10" Swivel Casters & (2) 10" Rigid Casters
(Optional (2) 10" Swivel Casters & (4) 10" Rigid Casters)
- Foot Brake
- Pull Bar

Accessories:

Options:

- Foam Filled Tires (**WA-10 FOAM CTR**) \$ 240.00
- Milk Crate (**B-03**) \$ 20.00
- Full Milk Crate Liner (**B-04**) \$ 19.50

Replacement parts:

- 10" Pneumatic Tire (**WA-10 TIRE**) \$ 24.00
- 10" Pneumatic Tube (**WA-10 TUBE**) \$ 12.00
- 10" Pneumatic Rigid Caster Wheel (**W-10 RCX**) \$ 88.00
- 10" Pneumatic Swivel Caster Wheel (**W-10 SCX**) \$ 91.00

Shipping Dimensions: L56" x W30" x H22" (245 lbs.) w/Pallet

L142.2cm x W76.2cm x H55.9cm (111.4 kgs.) w/Pallet

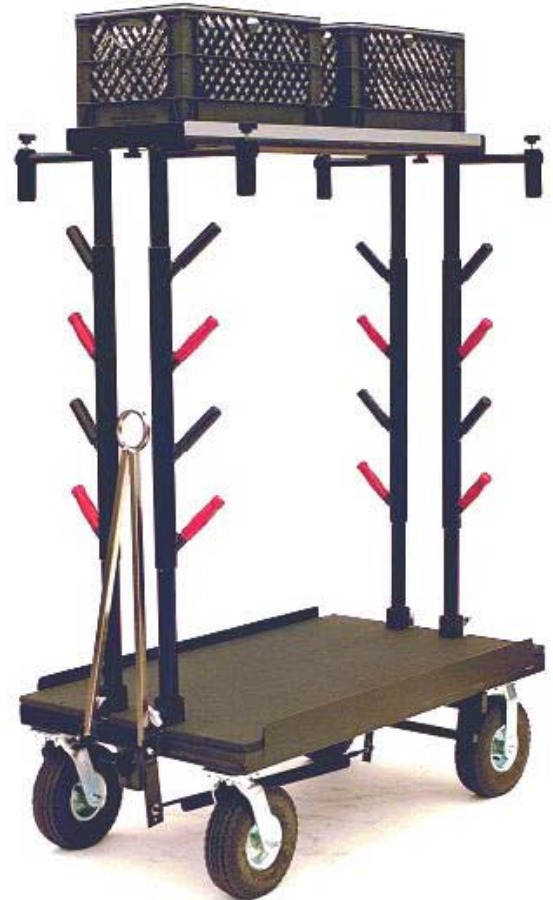

NOTE: Milk Crates not included





Ditty Cart

Part No. SB-02

Sale Price: \$ 1,710.00

Material: Steel

Color: Black Hammertone

Max. Capacity: 700 lbs. / 318 kgs.

Weight: 119 lbs. / 54 kgs.

Dimensions: L28 1/2" x W23" x H43"
L72.4cm x W58.4cm x H109.2cm

Features:

- (3) Ditty Drawers (D17" x W13" x H3") (D43.2cm x W33cm x H7.6cm)
- (2) Sliding Milk Crate Compartments
- Top Pan Holds (1) Milk Crate (L18 1/2" x W12 1/4") (L47cm x W31.1cm)
- (2) Side Gel Racks (Accommodates 14 Gels)
- Wheels (2) 5" Thermal Swivel Casters with Brake & (2) 10" Pneumatic Offset Wheels
- Locking Bar

Accessories:

- Pull-out Work Board D17" x W13" x H3/4" (D43.2cm x W33cm x H1.9cm) (**DRAWER-500**) \$ 95.00

Options:

- Milk Crate (**B-03**) \$ 20.00
- Half Milk Crate (**B-05**) \$ 20.00
- Full Milk Crate Liner (**B-04**) \$ 19.50
- Half Milk Crate Liner (**B-06**) \$ 19.00
- Foam Filled Tires (**WA-10 FOAM OS**) \$ 120.00

Replacement parts:

- Ditty Drawer (**DRAWER-02**) \$ 125.00
- 5" Thermal Swivel Caster with Brake (**W-05 SCBRX**) \$ 28.00
- 10" Pneumatic Tire (**WA-10 TIRE**) \$ 24.00
- 10" Pneumatic Tube (**WA-10 TUBE**) \$ 12.00
- 10" Pneumatic Offset Wheel (**W-10 OS34X**) \$ 65.00
- 3/4" Sealed Bearing (**WA-34 BR**) \$ 2.75 (Need (2) per Wheel)

Shipping Dimensions: L31" x W24" x H45" (125 lbs.)
L78.7cm x W61cm x H114.3cm (56.8 kgs.)



NOTE: Milk Crates not included



4-Crate Vertical Set Box Cart

Part No. SB-04V

Sale Price: \$ 2,370.00

Material: Steel

Color: Black Hammertone

Max. Capacity: 800 lbs. / 364 kgs.

Weight: 162 lbs. / 73.6 kgs.

Dimensions: L38 1/8" x W20 7/8" x H48 3/8"
L96.8cm x W53cm x H122.9cm

Features:

- (3) Full Size Set Box Drawer (D17" x W27 1/4" x H3") (D43.2cm x W69.2cm x H7.6cm)
- (4) Sliding Milk Crate Compartments
- Top Pan Holds (2) Milk Crate (L27 3/4" x W18") (L70.5cm x W45.7cm)
- (2) Side Gel Racks (Accommodates 12 Gels)
- Wheels (2) 8" Swivel Casters with Brake & (2) 8" Rigid Casters
- Locking Bar

Accessories:

- Pull-out Work Board D19" x W27 1/4" x H3/4" (D48.3cm x W69.2cm x H1.9cm) (**DRAWER-501 B**) \$ 115.00

Options:

- Milk Crate (**B-03**) \$ 20.00
- Half Milk Crate (**B-05**) \$ 20.00
- Full Milk Crate Liner (**B-04**) \$ 19.50
- Half Milk Crate Liner (**B-06**) \$ 19.00
- Foam Filled Tires (**WA-08 FOAM CTR**) \$ 208.00

Replacement parts:

- Full Size Set Box Drawer (**DRAWER-01 AL**) \$ 255.00
- 8" Pneumatic Tire (**WA-08 TIRE**) \$ 22.00
- 8" Pneumatic Tube (**WA-08 TUBE**) \$ 11.00
- 8" Pneumatic Swivel Caster Wheel with Brake (**W-08 SCBRX**) \$ 85.00
- 8" Pneumatic Rigid Caster Wheel (**W-08 RCX**) \$ 80.00

Shipping Dimensions: L39" x W21" x H49" (175 lbs.)
L99.1cm x W53.3cm x H124.5cm (79.6 kgs.)



NOTE: Milk Crates not included



6-Crate Vertical Set Box Cart

Part No. SB-06V

Sale Price: \$ 2,010.00

Material: Steel

Color: Black Hammertone

Max. Capacity: 800 lbs. / 364 kgs.

Weight: 133 lbs. / 60.5 kgs.

Dimensions: L38 1/8" x W20 7/8" x H48 3/8"
L96.8cm x W53cm x H122.9cm

Features:

- (6) Sliding Milk Crate Compartments
- Top Pan Holds (3) Milk Crate L42" x W18" (L106.7cm x W45.7cm)
- Wheels (2) 8" Swivel Casters with Brakes & (2) 8" Rigid Casters
- Locking Bar
- Pull Bar

Accessories:

- Gel Holder (Single) (**GEL SB-S**) \$ 245.00
- Gel Holder (Double) (**GEL SB-D**) \$ 325.00

Options:

- Milk Crate (**B-03**) \$ 20.00
- Full Milk Crate Liner (**B-04**) \$ 19.50
- Foam Filled Tires (**WA-08 FOAM CTR**) \$ 208.00

Replacement parts:

- 8" Pneumatic Tire (**WA-08 TIRE**) \$ 22.00
- 8" Pneumatic Tube (**WA-08 TUBE**) \$ 11.00
- 8" Pneumatic Swivel Caster Wheel with Brake (**W-08 SCBRX**) \$ 85.00
- 8" Pneumatic Rigid Caster Wheel (**W-08 RCX**) \$ 80.00

Shipping Dimensions: L39" x W21" x H49" (145 lbs.)

L99.1cm x W53.3cm x H124.5cm (65.9 kgs.)



NOTE: Milk Crates not included

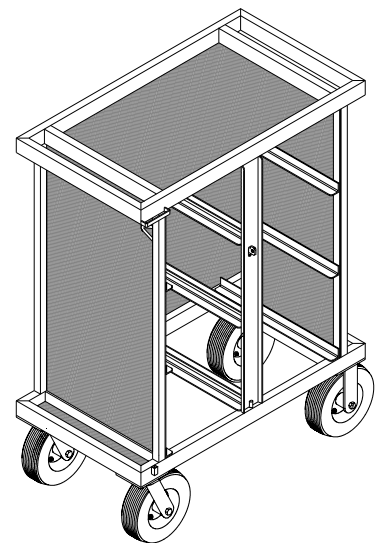
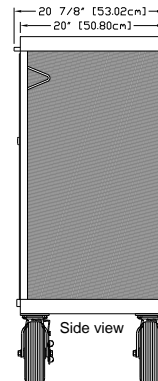
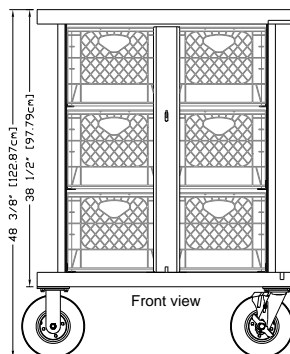
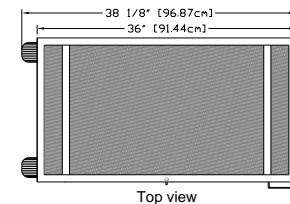



7-Crate Set Box Cart

Part No. SB-07

Sale Price: \$ 2,995.00

Material: Steel

Color: Black Hammertone

Max. Capacity: 1,000 lbs. / 454 kgs.

Weight: 236 lbs. / 107.3 kgs.

Dimensions: L47 1/8" x W26" x H57 1/4"
L119.7cm x W66cm x H145.5cm

Features:

- (3) Full Size Set Box Drawer (D17" x W27 1/4" x H3") (D43.2cm x W69.2cm x H7.6cm)
- (7) Sliding Milk Crate Compartments
- Top Pan Holds (3) Milk Crate (L42" x W18") (L106.7cm x W45.7cm)
- Rear Storage Area (L42" x W5") (L139.7cm x W12.7cm)
- Wheels (2) 10" Swivel Casters & (2) 10" Rigid Casters
- Jockey Box Holds (1) Half Milk Crate
- Locking Bars (2)
- Pull Bar
- Foot Brake

Accessories:

- Rear Fold-Down Table (**TB-42**) \$ 428.00
- Pull-out Work Board D19" x W27 1/4" x H3/4" (D48.3cm x W69.2cm x H1.9cm) (**DRAWER-501 B**) \$ 115.00

Options:

- Milk Crate (**B-03**) \$ 20.00
- Half Milk Crate (**B-05**) \$ 20.00
- Full Milk Crate Liner (**B-04**) \$ 19.50
- Half Milk Crate Liner (**B-06**) \$ 19.00
- Foam Filled Tires (**WA-10 FOAM CTR**) \$ 240.00
- Additional (2) 10" Pneumatic Rigid Caster Wheel (**W-10 RCX**) \$ 176.00
- Additional (2) 10" Foam Filled Tires (**WA-10 FOAM CTR**) \$ 120.00

Replacement parts:

- Full Size Set Box Drawer (**DRAWER-01**) \$ 255.00
- 10" Pneumatic Tire (**WA-10 TIRE**) \$ 24.00
- 10" Pneumatic Tube (**WA-10 TUBE**) \$ 12.00
- 10" Pneumatic Rigid Caster Wheel (**W-10 RCX**) \$ 88.00
- 10" Pneumatic Swivel Caster Wheel (**W-10 SCX**) \$ 91.00

Shipping Dimensions: L49" x W27" x H58" (255 lbs.)
L124.5cm x W69cm x H147.3cm (115.9 kgs.)



NOTE: Milk Crates not included



9-Crate Set Box Cart

Part No. SB-09

Sale Price: \$ 2,695.00

Material: Steel

Color: Black Hammertone

Max. Capacity: 1,000 lbs. / 454 kgs.

Weight: 214 lbs. / 97.3 kgs.

Dimensions: L47 1/8" x W26" x H57 1/4"
L119.7cm x W66cm x H145.5cm

Features:

- (9) Sliding Milk Crate Compartments
- Top Pan Holds (3) Milk Crate (L42" x W18") (L106.7cm x W45.7cm)
- Rear Storage Area (L42" x W5") (L139.7cm x W12.7cm)
- Wheels (2) 10" Swivel Casters & (2) 10" Rigid Casters
- Jockey Box Holds (1) Half Milk Crate
- Locking Bars (2)
- Pull Bar
- Foot Brake

Accessories:

- Rear Fold-Down Table **(TB-42)** \$ 428.00

Options:

- Milk Crate **(B-03)** \$ 20.00
- Half Milk Crate **(B-05)** \$ 20.00
- Full Milk Crate Liner **(B-04)** \$ 19.50
- Half Milk Crate Liner **(B-06)** \$ 19.00
- Foam Filled Tires **(WA-10 FOAM CTR)** \$ 240.00
- Additional (2) 10" Pneumatic Rigid Caster Wheel **(W-10 RCX)** \$ 176.00
- Additional (2) 10" Foam Filled Tires **(WA-10 FOAM CTR)** \$ 12.00

Replacement parts:

- 10" Pneumatic Tire **(WA-10 TIRE)** \$ 24.00
- 10" Pneumatic Tube **(WA-10 TUBE)** \$ 12.00
- 10" Pneumatic Rigid Caster Wheel **(W-10 RCX)** \$ 88.00
- 10" Pneumatic Swivel Caster Wheel **(W-10 SCX)** \$ 91.00

Shipping Dimensions: L49" x W27" x H58" (221 lbs.)
L124.5cm x W69cm x H147.3cm (100.5 kgs.)



NOTE: Milk Crates not included



8-Crate Set Box Platinum Cart

Part No. SB-08 PS

Sale Price: \$ 3,575.00

Material: Steel

Color: Black Hammertone

Max. Capacity: 1,000 lbs. / 454 kgs.

Weight: 385 lbs. / 175 kgs.

Dimensions: L63 1/8" x W28" x H57 1/4"

L160.3cm x W71.1cm x H145.4cm

Features:

- (4) Small Birch Wood Drawers (D19 1/2" x W26 1/2" x H5 1/4") (D49.5cm x W67.3cm x H13.4cm)
- (1) Large Birch Wood Drawer (D19 1/2" x W26 1/2" x H10 3/4") (D49.5cm x W67.3cm x H27.3cm)
- Pull-Out Work Board (D19 1/2" x W26 1/2") (D49.5cm x W67.3cm)
- Rear Fold-Down Table (L56" x W24") (L142.2cm x W61cm)
- (3) Sliding Milk Crate Compartments
- (5) Sliding Half Milk Crate Compartments
- Top Pan Holds (4) Milk Crates (L56" x W18") (L142.2cm x W45.7cm)
- Jockey Box Holds (2) Half Milk Crates
- Wheels (2) 10" Swivel Casters & (2) 10" Rigid Casters
(Optional (2) 10" Swivel Casters & (4) 10" Rigid Casters)
- Foot Brake
- Pull Bar
- (2) Locking Bars

Accessories:

Options:

- Milk Crate **(B-03)** \$ 20.00
- Half Milk Crate **(B-05)** \$ 20.00
- Full Milk Crate Liner **(B-04)** \$ 19.50
- Half Milk Crate Liner **(B-06)** \$ 19.00
- Foam Filled Tires **(WA-10 FOAM CTR)** \$ 240.00
- Additional (2) 10" Pneumatic Rigid Caster Wheel **(W-10 RCX)** \$ 176.00
- Additional (2) 10" Foam Filled Tires **(WA-10 FOAM CTR)** \$ 120.00

Replacement parts:

- Small Birch Wood Drawer **(DRAWER-502)** \$ 200.00
- Large Birch Wood Drawer **(DRAWER-503)** \$ 265.00
- Pull-Out Work Board **(DRAWER-501 A)** \$ 140.00
- Rear Fold-Down Table **(SB-08 PS TABLE)** \$ 448.00
- 10" Pneumatic Tire **(WA-10 TIRE)** \$ 24.00
- 10" Pneumatic Tube **(WA-10 TUBE)** \$ 12.00
- 10" Pneumatic Rigid Caster Wheel **(W-10 RCX)** \$ 88.00
- 10" Pneumatic Swivel Caster Wheel **(W-10 SCX)** \$ 91.00

Shipping Dimensions: L64" x W29" x H58" (400 lbs.)

L162.6cm x W73.7cm x H147.3cm (181.8 kgs.)



NOTE: Milk Crates not included





Prop-Chair Cart

Part No. P-07

Sale Price: \$ 2,275.00

Material: Steel

Color: Black Hammertone

Max. Capacity: 1,000 lbs. / 454 kgs.

Weight: 205 lbs. / 93.2 kgs.

Dimensions: L60" x W28" x H58 1/2"

L152.4cm x W71.1cm x H148.6cm

Features:

- Inside Area Holds (12) Director's Chairs (L47 3/4" x W22" x H38") (L121.3cm x W55.9cm x H96.5cm)
- (2) Pull-Out Chair Holders (Hold (6) Director's Chairs)
- Top Storage Pan Holds (3) Milk Crates (L45 3/4" x W20") (L116.2cm x W50.8cm)
- Rear Table Storage Area (L56" x W6") (L142.2cm x W15.2cm)
- Jockey Box holds (2) Half Milk Crates
- Wheels (2) 10" Swivel Casters & (2) 10" Rigid Casters (Optional (2) 10" Swivel Casters & (4) 10" Rigid Casters)
- Foot Brake

Accessories:

Options:

- Milk Crate **(B-03)** \$ 20.00
- Half Milk Crate **(B-05)** \$ 20.00
- Full Milk Crate Liner **(B-04)** \$ 19.50
- Half Milk Crate Liner **(B-06)** \$ 19.00
- Foam Filled Tires **(WA-10 FOAM CTR)** \$ 240.00
- Additional (2) 10" Pneumatic Rigid Caster Wheel **(W-10 RCX)** \$ 176.00
- Additional (2) 10" Foam Filled Tires **(WA-10 FOAM CTR)** \$ 120.00

Replacement parts:

- 10" Pneumatic Tire **(WA-10 TIRE)** \$ 24.00
- 10" Pneumatic Tube **(WA-10 TUBE)** \$ 12.00
- 10" Pneumatic Rigid Caster Wheel **(W-10 RCX)** \$ 88.00
- 10" Pneumatic Swivel Caster Wheel **(W-10 SCX)** \$ 91.00

Shipping Dimensions: L60" x W29" x H59" (215 lbs.)

L152.4cm x W73.7cm x H149.9cm (97.7 kgs.)



NOTE: Milk Crates not included



Monitor Mover Cart

Part No. V-02 TR

Sale Price: \$ 995.00

Material: Steel

Color: Black Hammertone

Max. Capacity: 500 lbs / 227 kgs..

Weight: 40 lbs. / 18.2 kgs.

Dimensions: L31" x W26" x H43"
L78.7cm x W66cm x H109.2cm

Features:

- Fully Collapsible
- Adjustable Riser with 5/8" Pin Accommodates Monitor Height
- Battery Pan (D12" x W15 1/2" x H2") (D30.5cm x W39.4cm x H5.1cm)
- Wheels (2) 5" Thermal Swivel Casters with Brake & (2) 10" Pneumatic Offset Wheels

Accessories:

- Mag Dual Video 5/8" Monitor Bracket (**MAG-V**) \$ 170.00
- Mag Adjustable Dual Video Baby Riser with 5/8" Baby Receiver (**MAG-VPR**) \$ 405.00
- Mag LCD Tilter Head with 75/100mm VESA Adapter Plate (3 - 24 lbs.) (**MAG-LCD TH-LD BK-X**) \$ 98.00
- Mag LCD 4" Tilt Head Pin Adapter (**MAG-LCD MR-04**) \$ 50.00

Options:

- Foam Filled Tires (**WA-10 FOAM OS**) \$ 120.00

Replacement parts:

- 5" Thermal Swivel Caster with Brake (**W-05 SCBRX**) \$ 28.00
- 10" Pneumatic Tire (**WA-10 TIRE**) \$ 24.00
- 10" Pneumatic Tube (**WA-10 TUBE**) \$ 12.00
- 10" Pneumatic Offset Wheel (**W-10 OS34X**) \$ 65.00
- 3/4" Sealed Bearing (**WA-34 BR**) \$ 2.75 (Need (2) per Wheel)

Shipping Dimensions: L24" x W24" x H13" (44 lbs.)
L61cm x W61cm x H33cm (20 kgs.)



V-02 TR Shown with optional Adjustable Dual Video Baby Riser, VESA Plates, Tilt Heads & Tilt Head Pin Adapters

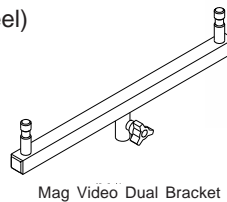
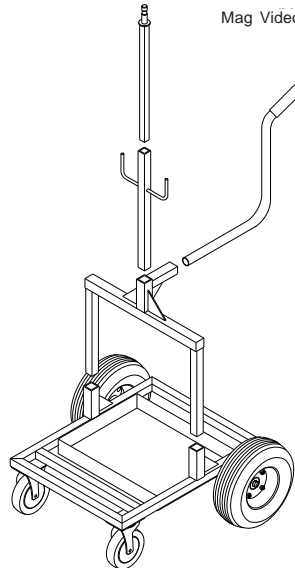

Mag Video Dual Bracket

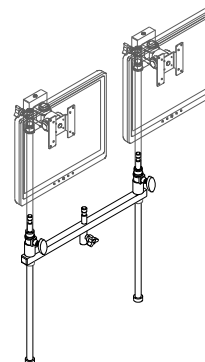

Mag Adjustable Dual Video Baby Riser with 5/8" Baby Receiver

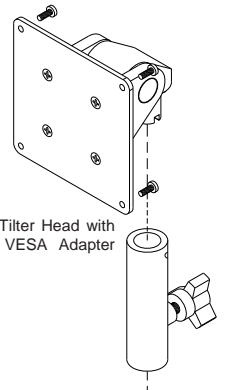

Mag LCD Tilter Head with 75/100mm VESA Adapter Plate

Mag LCD 4" Tilt Head Pin Adapter



Shot Bag Cart

Part No. GE-20

Sale Price: \$ 1,110.00

Material: Steel

Color: Black Hammertone

Max. Capacity: 600 lbs. / 272.7 kgs.

Weight: 68 lbs. / 30.9 kgs.

Dimensions: D33 5/8" x W19 1/4" x H36 3/8"

D85.41cm x W48.9cm x H92.4cm

D26 3/4" x W19 1/4" x H27 1/2" (Handles down)

D68cm x W48.9cm x H69.9cm (Handles down)



Features:

- Holds (16-20) 15 lb. Shot Bags
- Retracting Handles allows you to store cart under truck shelving
- Carriage Base D20" x W11" x H16" (D50.8cm x W27.9cm x H40.6cm)
- (4) 10" Pneumatic Offset Wheels
- Hand Brake

Accessories:

Options:

- Foam Filled Tires (**WA-10 FOAM OS**) \$ 240.00

Replacement parts:

- 10" Pneumatic Tire (**WA-10 TIRE**) \$ 24.00
- 10" Pneumatic Tube (**WA-10 TUBE**) \$ 12.00
- 10" Pneumatic Offset Wheel (**W-10 OS34X**) \$ 65.00
- 3/4" Sealed Bearing (**WA-34 BR**) \$ 2.75 (Need (2) per Wheel)

Shipping Dimensions: L28" x W20" x H34" (110 lbs.) Includes pallet
L71.12cm x W50.8cm x H86.4cm (50 kgs.)



Shot Bag Cart shown with Handles Down

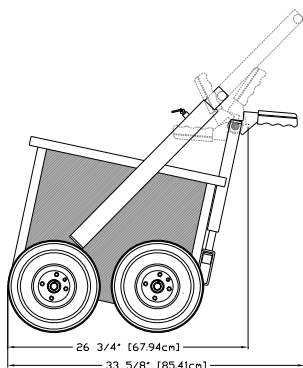
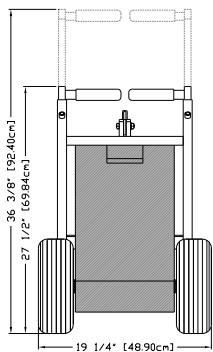
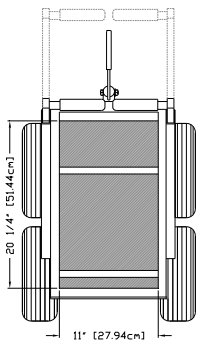



Long John Silver Stand Cart (Avenger)

Part No. GE-18

Sale Price: \$ 1,875.00

Material: Steel

Color: Black Hammertone

Max. Capacity: 400 lbs. / 364 kgs.

Weight: 109 lbs. / 49.5 kgs.

Dimensions: L42 1/4" x W25" x H53 11/16"

L104.1cm x W63.5cm x H136.4cm



Features:

- Transports Long John Silver Stand (Avenger)
- Clears all doors under 80" with Stand mounted
- One Man Operation
- (2) 8" Pneumatic Swivel Casters Wheels with Brakes & (2) 10" Offset Pneumatic Wheels
- Milk Crate Compartment
- Jockey Box
- Foot Brake

Accessories:

Options:

- Milk Crate **(B-03)** \$ 20.00
- Full Milk Crate Liner **(B-04)** \$ 19.50
- Foam Filled Tires **(WA-10 FOAM OS)** \$ 120.00
- Foam Filled Tires **(WA-08 FOAM CTR)** \$ 104.00

Replacement parts:

- 10" Pneumatic Tire **(WA-10 TIRE)** \$24.00
- 10" Pneumatic Tube **(WA-10 TUBE)** \$ 12.00
- 10" Pneumatic Offset Wheel **(W- OS34X)** \$ 65.00
- 8" Pneumatic Tire **(WA-08 TIRE)** \$ 22.00
- 8" Pneumatic Tube **(WA-08 TUBE)** \$ 12.00
- 8" Pneumatic Swivel Caster Wheel with Brakes **(W-08 SCBRX)** \$ 85.00

Shipping Dimensions: L37" x W26" x H61" (123 lbs.)

L94cm x W66cm x H155cm (56 kgs.)



NOTE: Milk Crates not included



Set Stand next to cart, lock brakes on cart



Rotate cart to align with stand, set Locking Pin



Rotate cart back



Long John Silver Jr. Stand Cart (Avenger)

Part No. GE-18 JR

Sale Price: \$ 1,875.00

Material: Steel

Color: Black Hammertone

Max. Capacity: 400 lbs. / 364 kgs.

Weight: 108 lbs. / 49.1 kgs.

Dimensions: L41 1/4" x W25" x H52 1/4"

L104.1cm x W63.5cm x H132.7cm



NOTE: Milk Crates not included

Features:

- Transports Long John Silver Junior Stand (Avenger)
- Clears all doors under 80" with Stand mounted
- One Man Operation
- (2) 8" Pneumatic Swivel Casters Wheels with Brakes & (2) 10" Offset Pneumatic Wheels
- Milk Crate Compartment
- Jockey Box
- Foot Brake

Accessories:

Options:

- Milk Crate (B-03) \$ 20.00
- Full Milk Crate Liner (B-04) \$ 19.50
- Foam Filled Tires (WA-10 FOAM OS) \$ 120.00
- Foam Filled Tires (WA-08 FOAM CTR) \$ 104.00

Replacement parts:

- 10" Pneumatic Tire (WA-10 TIRE) \$24.00
- 10" Pneumatic Tube (WA-10 TUBE) \$ 12.00
- 10" Pneumatic Offset Wheel (W- OS34X) \$ 65.00
- 8" Pneumatic Tire (WA-08 TIRE) \$ 22.00
- 8" Pneumatic Tube (WA-08 TUBE) \$ 11.00
- 8" Pneumatic Swivel Caster Wheel with Brakes (W-08 SCBRX) \$ 85.00

Shipping Dimensions: L37" x W26" x H61" (124 lbs.)

L94cm x W66cm x H155cm (56.4 kgs.)



Quick Release Pin (Close-up)



Set Stand next to cart, lock brakes on cart



Rotate cart to align with stand, set Locking Pin



Rotate cart back



Strato Safe B150P Stand Cart (Avenger)

Part No. GE-22

Sale Price: \$ 1,875.00

Material: Steel

Color: Black Hammertone

Max. Capacity: 400 lbs. / 364 kgs.

Weight: 107 lbs. / 48.7 kgs.

Dimensions: L41 1/4" x W25" x H55 7/8"

L104.8cm x W63.5cm x H141.9cm

Features:

- Transports Strato Safe B150P Stand (Avenger) with Pneumatic Wheels
- Clears all doors under 80" with Stand mounted
- One Man Operation
- (2) 8" Pneumatic Swivel Casters Wheels with Brakes & (2) 10" Offset Pneumatic Wheels
- Milk Crate Compartment
- Jockey Box
- Foot Brake

Accessories:

Options:

- Milk Crate (**B-03**) \$ 20.00
- Full Milk Crate Liner (**B-04**) \$ 19.50
- Foam Filled Tires (**WA-10 FOAM OS**) \$ 120.00
- Foam Filled Tires (**WA-08 FOAM CTR**) \$ 104.00

Replacement parts:

- 10" Pneumatic Tire (**WA-10 TIRE**) \$24.00
- 10" Pneumatic Tube (**WA-10 TUBE**) \$ 12.00
- 10" Pneumatic Offset Wheel (**W- OS34X**) \$ 65.00
- 8" Pneumatic Tire (**WA-08 TIRE**) \$ 22.00
- 8" Pneumatic Tube (**WA-08 TUBE**) \$ 11.00
- 8" Pneumatic Swivel Caster Wheel with Brakes (**W-08 SCBRX**) \$ 85.00

Shipping Dimensions: L37" x W26" x H61" (124 lbs.)

L94cm x W66cm x H155cm (56.4 kgs.)

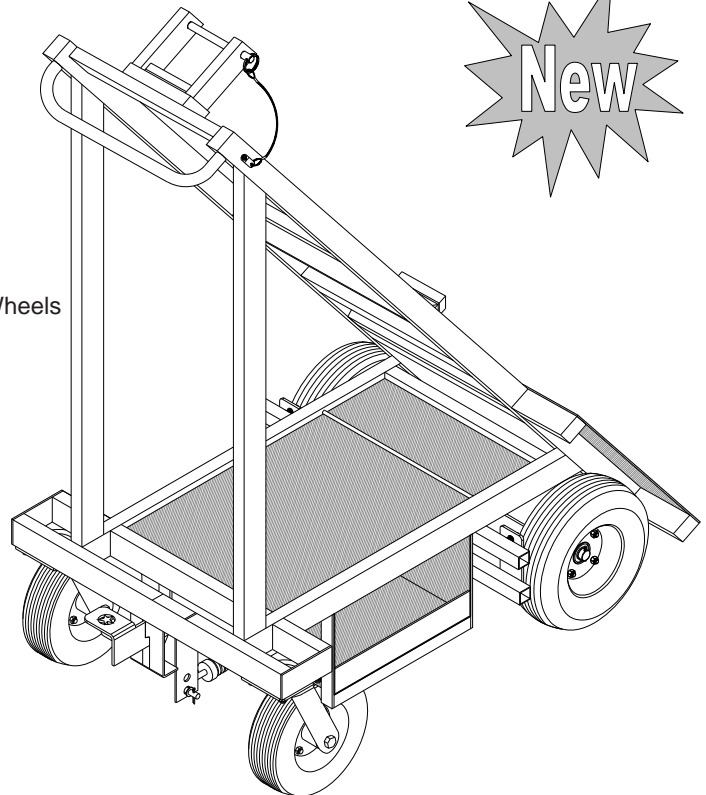

NOTE: Milk Crates not included

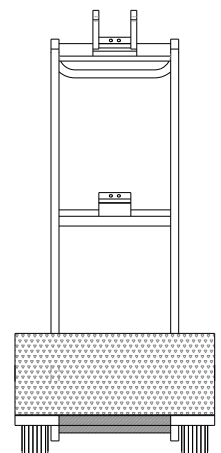
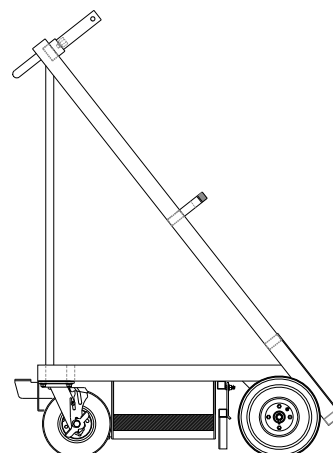
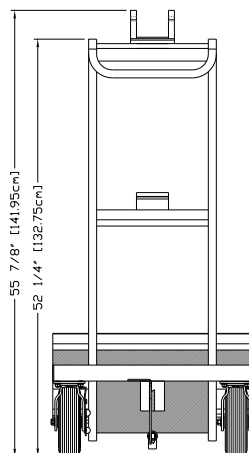
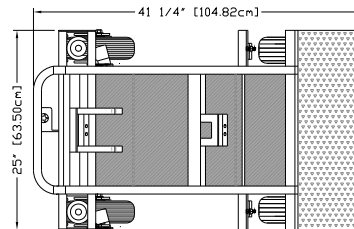



Strato Safe B150 Stand Cart UK (Avenger)

Part No. GE-22 UK

Sale Price: \$ 1,875.00

Material: Steel

Color: Black Hammertone

Max. Capacity: 400 lbs. / 364 kgs.

Weight: 107 lbs. / 48.7 kgs.

Dimensions: L41 1/4" x W25" x H52 3/4"
L104.8cm x W63.5cm x H134cm

Features:

- Transports Strato Safe B150 Stand (Avenger) with Solid Wheels (160 x 50)
- Clears all doors under 80" with Stand mounted
- One Man Operation
- (2) 8" Pneumatic Swivel Casters Wheels with Brakes & (2) 10" Offset Pneumatic Wheels
- Milk Crate Compartment
- Jockey Box
- Foot Brake

Accessories:

Options:

- Milk Crate (B-03) \$ 20.00
- Full Milk Crate Liner (B-04) \$ 19.50
- Foam Filled Tires (WA-10 FOAM OS) \$ 120.00
- Foam Filled Tires (WA-08 FOAM CTR) \$ 104.00

Replacement parts:

- 10" Pneumatic Tire (WA-10 TIRE) \$24.00
- 10" Pneumatic Tube (WA-10 TUBE) \$ 12.00
- 10" Pneumatic Offset Wheel (W- OS34X) \$ 65.00
- 8" Pneumatic Tire (WA-08 TIRE) \$ 22.00
- 8" Pneumatic Tube (WA-08 TUBE) \$ 11.00
- 8" Pneumatic Swivel Caster Wheel with Brakes (W-08 SCBRX) \$ 85.00

Shipping Dimensions: L37" x W26" x H61" (124 lbs.)
L94cm x W66cm x H155cm (56.4 kgs.)

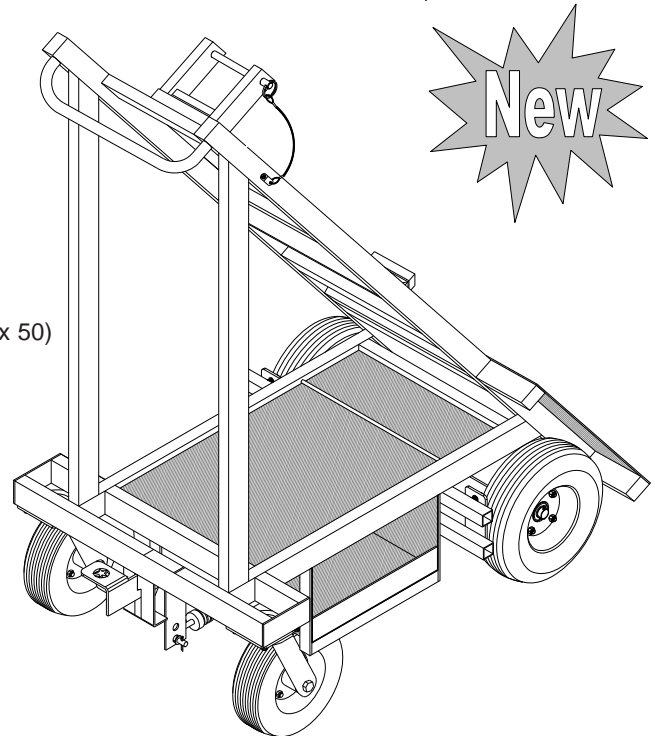

NOTE: Milk Crates not included

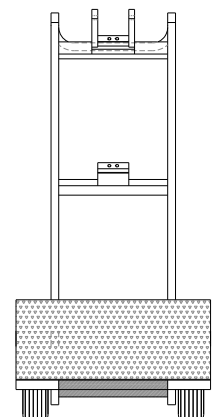
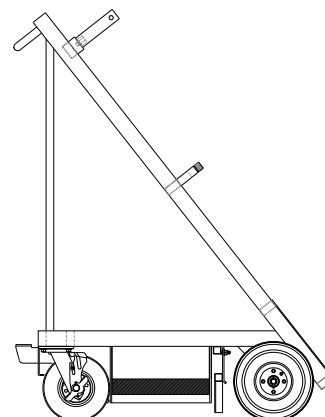
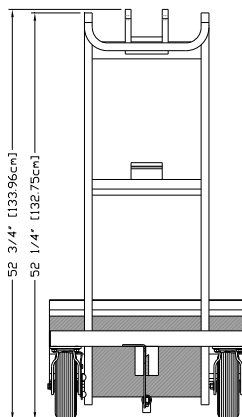
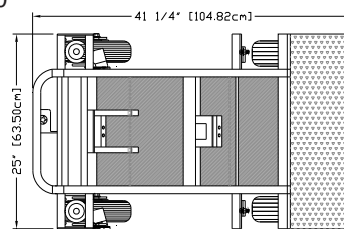



Blackbird Stand Cart (American)

Part No. GE-21

Sale Price: \$ 1,875.00

Material: Steel

Color: Black Hammertone

Max. Capacity: 400 lbs. / 364 kgs.

Weight: 108 lbs. / 49.1 kgs.

Dimensions: L41 17/32" x W25" x H52 7/8"
L104.1cm x W63.5cm x H134.3cm

Features:

- Transports Blackbird Stand (American)
- Clears all doors under 80" with Stand mounted
- One Man Operation
- (2) 8" Pneumatic Swivel Casters Wheels with Brakes & (2) 10" Offset Pneumatic Wheels
- Milk Crate Compartment
- Jockey Box
- Foot Brake

Accessories:

Options:

- Milk Crate **(B-03)** \$ 20.00
- Full Milk Crate Liner **(B-04)** \$ 19.50
- Foam Filled Tires **(WA-10 FOAM OS)** \$ 120.00
- Foam Filled Tires **(WA-08 FOAM CTR)** \$ 104.00

Replacement parts:

- 10" Pneumatic Tire **(WA-10 TIRE)** \$24.00
- 10" Pneumatic Tube **(WA-10 TUBE)** \$ 12.00
- 10" Pneumatic Offset Wheel **(W- OS34X)** \$ 65.00
- 8" Pneumatic Tire **(WA-08 TIRE)** \$ 22.00
- 8" Pneumatic Tube **(WA-08 TUBE)** \$ 11.00
- 8" Pneumatic Swivel Caster Wheel with Brakes **(W-08 SCBRX)** \$ 85.00

Shipping Dimensions: L37" x W26" x H61" (122 lbs.)
L94cm x W66cm x H155cm (55.5 kgs.)



NOTE: Milk Crates not included

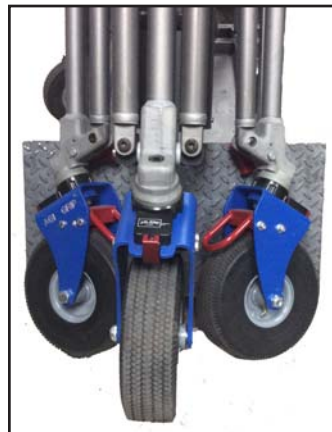



Stand Cart Specifications

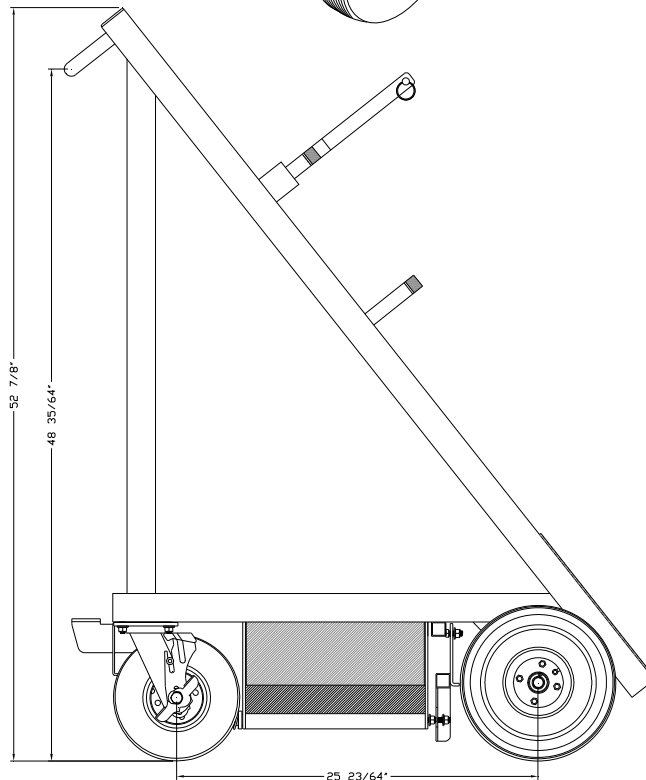
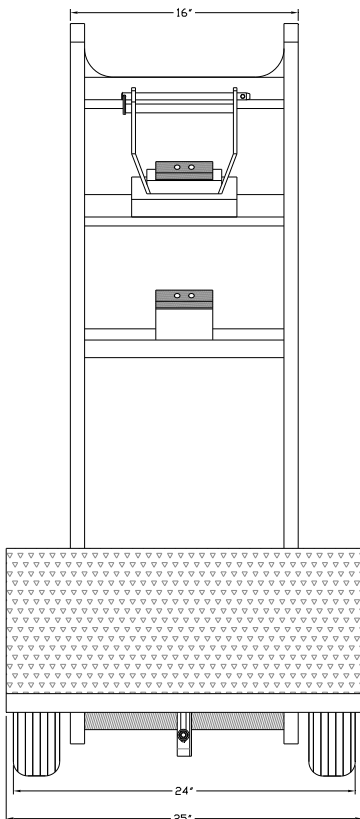
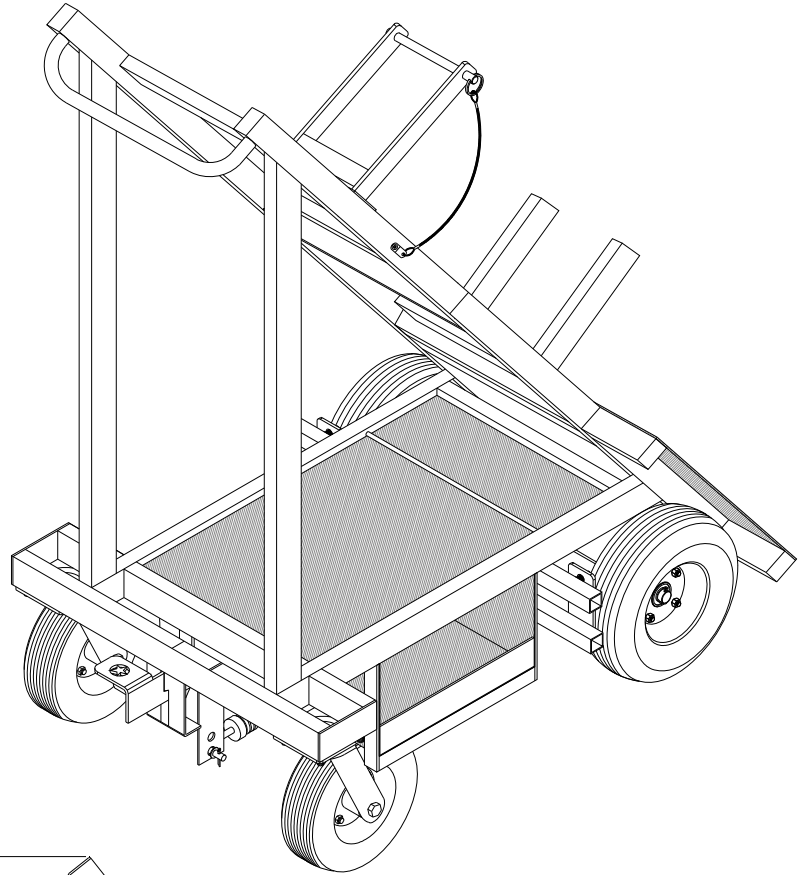
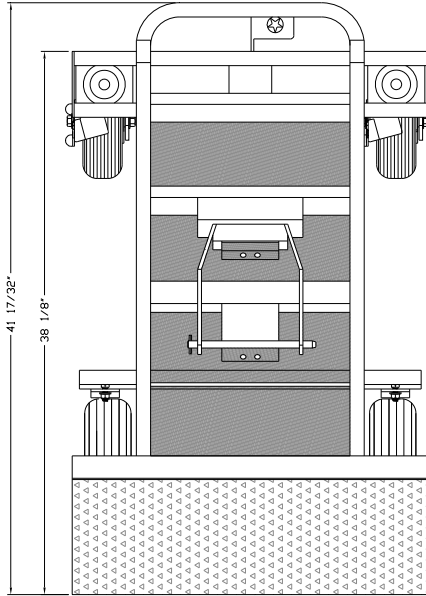



Lamp Dolly Base

Part No. E-10ARRIMAX

Sale Price: \$ 895.00

Material: Steel

Color: Black Hammertone

Max. Capacity: 800 lbs. / 364 kgs.

Weight: 65 lbs. / 30 kgs.

Dimensions: L41" x W31 1/2" x H10 3/4"
L104cm x W80cm x H27.3cm

Features:

- Transports large ARRIMAX 12K / 18K Lights
- (2) 8" Pneumatic Swivel Casters Wheels with Brakes & (2) 8" Rigid Caster Wheels
- HD Ratchet straps (2) for transportation security

Accessories:

Options:

- Foam Filled Tires (**WA-08 FOAM CTR**) \$ 208.00

Replacement parts:

- 8" Pneumatic Tire (**WA-08 TIRE**) \$ 22.00
- 8" Pneumatic Tube (**WA-08 TUBE**) \$ 11.00
- 8" Pneumatic Swivel Caster Wheel with Brakes (**W-08 SCBRX**) \$ 85.00
- 8" Pneumatic Rigid Caster Wheel (**W-08 RCX**) \$ 80.00

Shipping Dimensions: L42" x W33" x H12" (75 lbs.)
L107cm x W83.8cm x H106.7cm (34.1 kgs.)

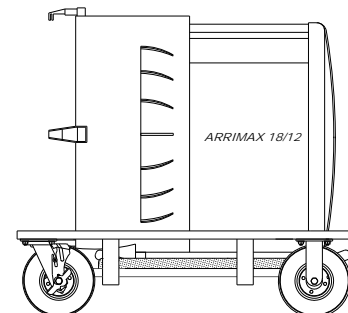
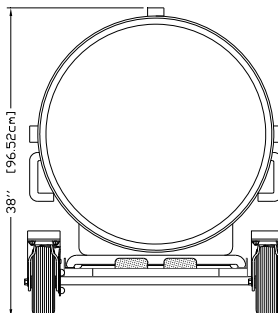
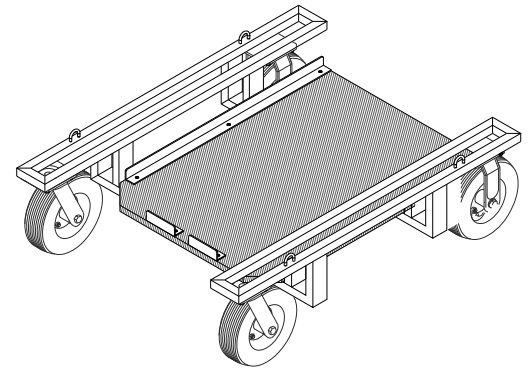
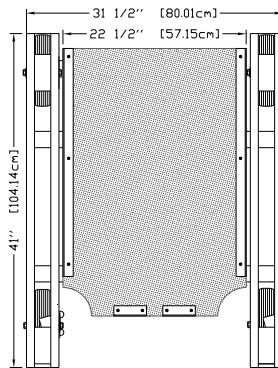



Big Wheels

Part No. G-08

Sale Price: \$ 2,495.00

Material: Steel

Color: Black Hammertone

Max. Capacity: 500 lbs. / 227.3 kgs.

Weight: 75 lbs. / 34.1 kgs.

Dimensions: D19" x W25" x H18"
L48.3cm x W63.5cm x H45.7cm

Features:

- Transports in rear seat or trunk of small car
- Minimum storage space required
- Cradles to stand's own 10" wheels
- Pull Handle / Braking system
- (6) 19" Pneumatic Balloon Wheels

Accessories:

Options:

Replacement parts:

- 19" Sand Crawler Pneumatic Wheel (**W-19 SCW**) \$ 298.00
- 19" Sand Crawler Wheel Bearings (**W19 SCW-A**) \$ 15.00 (Need 2 per wheel)
- 19" Sand Crawler Tire (**W-19 SCW-B**) \$ 258.00
- 19" Sand Crawler Wheel Hub (**W19 SCW-C**) \$ 54.00

Shipping Dimensions: L52" x W31" x H32" (90 lbs.)
L132.1cm x W78.7cm x H81.3cm (40.9 kgs.)

- Lightweight device uses special wheels to transport Super Crank & Roadrunner stand over sand, grass, snow and rough terrain, replacing conventional desert dollies and klikiti-claks.

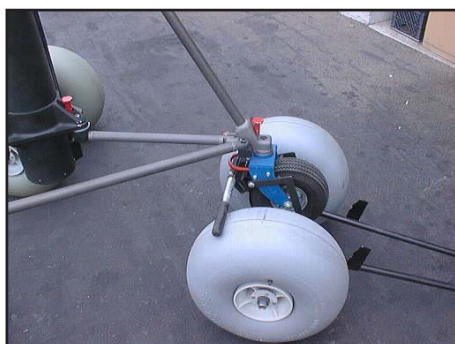
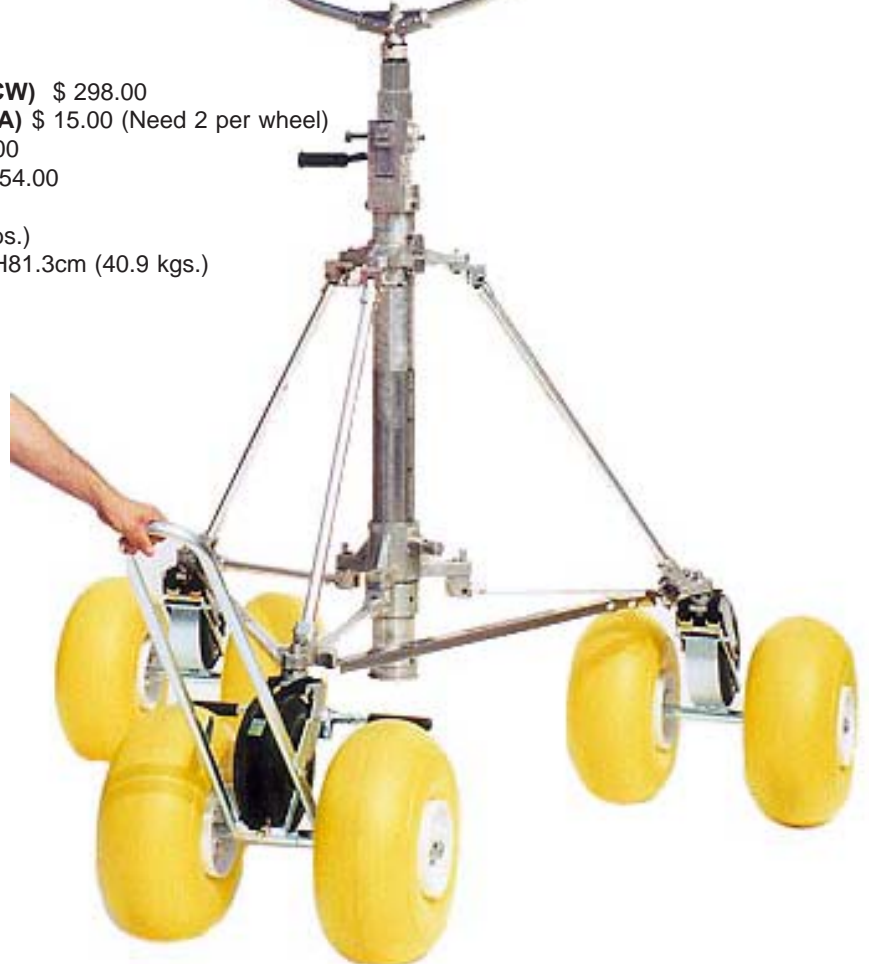



Generator Armor (Honda 3000)

Part No. GEN-02

Sale Price: \$ 1,275.00

Material: Steel

Color: Black Hammertone

Max. Capacity: 800 lbs. / 364 kgs.

Weight: 52 lbs. / 23.6 kgs.

Dimensions: L26 1/8" x W20 1/2" x H32 5/8"
L66.4cm x W52cm x H82.9cm

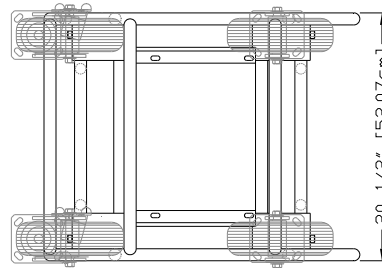

Features:

- Accommodates Honda 3000 Generator
- Generator mounts easily to armor
- Folding handles tuck away within armor
- Wheels: (2) 8" Swivel Casters with Brake and (2) 8" Rigid Casters

Accessories:

- Sand/Dune Wheel Kit (**TR-04 W**) \$ 995.00

Options:

- Foam Filled Tires (**WA-08 FOAM CTR**) \$ 208.00

Replacement parts:

- 8" Pneumatic Tire (**WA-08 TIRE**) \$ 22.00
- 8" Pneumatic Tube (**WA-08 TUBE**) \$ 11.00
- 8" Pneumatic Swivel Caster Wheel (**W-08 SCBRX**) \$ 85.00
- 8" Pneumatic Rigid Caster Wheel (**W-08 RCX**) \$ 80.00

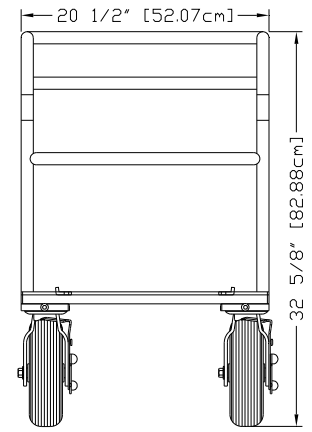
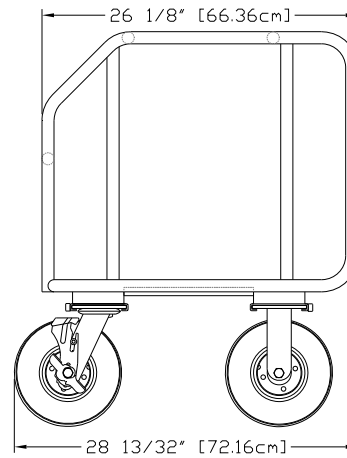

Shipping Dimensions: L27" x W27" x H22" (61 lbs.)
L68.6cm x W68.6cm x H55.9cm (27.7 kgs.)





Generator Armor (Honda 6500 & 7000)

Part No. GEN-01

Sale Price: \$ 1,530.00

Material: Steel

Color: Black Hammertone

Max. Capacity: 800 lbs. / 364 kgs.

Weight: 66 lbs. / 30 kgs.

Dimensions: L35 3/4" x W23 1/4" x H35 1/4"
L90.8cm x W59.1cm x H89.5cm

Features:

- Accommodates Honda 6500 & 7000 Generator
- Generator mounts easily to armor
- Folding handles tuck away within armor
- Wheels: (2) 8" Swivel Casters with Brake and (2) 8" Rigid Casters
- Foot Brake

Accessories:

- Sand/Dune Wheel Kit (TR-04 W) \$ 995.00

Options:

- Foam Filled Tires (WA-08 FOAM CTR) \$ 208.00

Replacement parts:

- 8" Pneumatic Tire (WA-08 TIRE) \$ 22.00
- 8" Pneumatic Tube (WA-08 TUBE) \$ 11.00
- 8" Pneumatic Swivel Caster Wheel (W-08 SCBRX) \$ 85.00
- 8" Pneumatic Rigid Caster Wheel (W-08 RCX) \$ 80.00

Shipping Dimensions: L37" x W25" x H36" (76 lbs.)
L94cm x W63.5cm x H91.4cm (34.6 kgs.)



Honda 6500 Generator Armor shown with handles down (Front view)

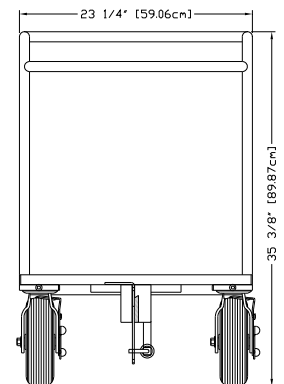
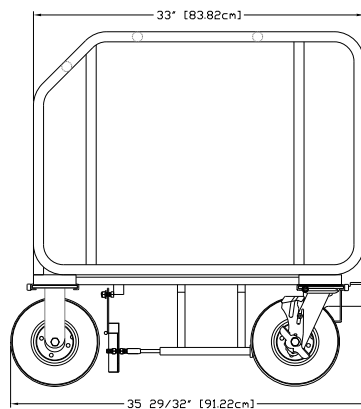
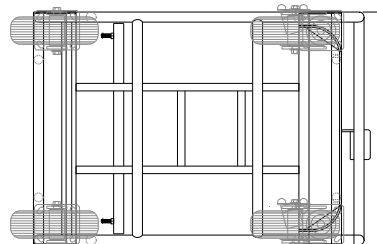



Grip & Electric Cart Equipment

Milk Crates

Style Nos. B-03 & B-05



Milk Crate (Gray) B-03
L19" x W13" x H11" (4.8 lbs.)
L48.3cm x W33cm x H27.9cm (2.2 kgs.)
Sale Price \$ 20.00

School Crate (Gray) B-05
L19" x W13" x H6 1/2" (3.7 lbs.)
L48.3cm x W33cm x H16.5cm (1.7 kgs.)
Sale Price \$ 20.00

Milk Crate Liner

Style No. B-04

- Allows crates to perform as drawers
- Fits standard milk crates
- 24ga. Galvanized sheet metal

L17 1/2" x W11 1/2" x H10" (4 lbs.)
L44.5cm x W29.2cm x H25.4cm (1.8 kgs.)
Sale Price \$ 19.50

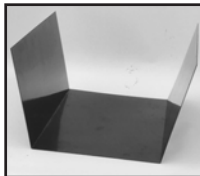

School Crate Liner

Style No. B-06

L17 1/2" x W11 1/2" x H5 1/2" (3 lbs.)
L44.5cm x W29.2cm x H14cm (1.4 kgs.)
Sale Price \$ 19.00

Gel Holders

GEL G-01 (4 x 4 Grande, 4 x 4 Mini & 4 x 4 Coasters)

- Holds (16) gels

L47 1/2" x D4 3/4" x H27 1/2" (20 lbs.)
L120.7cm x D12.1cm x H69.9cm (9 kgs.)
Sale Price \$425.00

GEL SB-S (4-Crate & 6-Crate)

- Holds (13) gels

L41" x D4 3/4" x H27 1/2" (20 lbs.) (Single row)
L104.1cm x D12.1cm x H69.9cm (9 kgs.)
Sale Price \$ 245.00

GEL SB-D (4-Crate & 6-Crate)

- Holds (26) gels

L41" x D8.25" x H28" (30 lbs.) (Double row)
L104.1cm x D21cm x H71.1cm (13.6 Kgs.)
Sale Price \$ 325.00

18" x 24" Net Basket Double

Style No. B-01D

Sale Price: \$ 515.00
Material: Steel
Color: Gray Hammertone
Max. Capacity: 150 lbs. / 68.2 kgs.
Weight: 15 lbs. / 6.8 kgs.
Dimensions: D10 3/4" x W20" x H22 1/4"
D27.3cm x W50.8cm x H56.5cm

Features:

- Holds: (17) Flags 18" x 24" (46cm x 61cm)
- Double compartment
- Attaches 4 x 4 Coaster Carts and front of 24" x 36" (61cm x 92cm) Net Baskets

Shipping Dims:

L12" x W21" x H25" (18 lbs)
L30.5cm x W53.3cm x H63.5cm (8.2 kgs.)



24" x 36" Net Basket Double

Style No. B-02D

Sale Price: \$ 575.00
Material: Steel
Color: Gray Hammertone
Max. Capacity: 150 lbs. / 68.2 kgs.
Weight: 21.8 lbs. / 9.9 kgs.
Dimensions: D10 1/2" x W27 3/4" x H30 3/4"
D26.7cm x W70.5cm x H78cm

Features:

- Holds: (17) flags 24" x 36" (61cm x 92cm)
- Double compartment
- Attaches to EZ-Load Grip/Electric Cart

Shipping Dims:

L29" x W13" x H34" (27 lbs.)
L73.7cm x W33cm x H86.4cm (12.3 kgs.)



24" x 36" Net Basket Triple

Style No. B-02T

Sale Price: \$ 720.00
Material: Aluminum
Color: Gray Hammertone
Max. Capacity: 150 lbs. / 68.2 kgs.
Weight: 27.4 lbs. / 12.5 kgs.
Dimensions: D14.1/4" x W27 3/4" x H30"
D36.2cm x W70.5cm x H76.2cm

Features:

- Holds: (26) Flags 24" x 36" (61cm x 92cm)
- Triple compartment
- Attaches to: Super Duz-All, Grip Senior, Grip Junior and 4 X 4 Coaster Carts

Shipping Dims:

L29" x W16" x H35" (36 lbs)
L73.7cm x W41cm x H88.9cm (16.4 kgs.)



24" x 36" Net Basket Triple (Mobile)

Style No. B-02T MOB

Sale Price: \$ 850.00
Material: Aluminum
Color: Gray Hammertone
Max. Capacity: 150 lbs. / 68.2 kgs.
Weight: 40 lbs. / 18.2 kgs.
Dimensions: D14.1/4" x W27 3/4" x H34 5/8"
D36.2cm x W70.5cm x H88cm

Features:

- Holds: (26) Flags 24" x 36" (61cm x 92cm)
- Triple compartment
- (2) 3" Swivel Casters with brakes
- (2) 3" Swivel Casters
- Attaches to: Super Duz-All, Grip Senior, Grip Junior and 4 X 4 Coaster Carts

Shipping Dims:

L29" x W16" x H39" (47 lbs)
L73.7cm x W41cm x H99.1cm (16.4 kgs.)

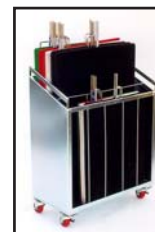



Camera Case Cart (Aluminum)

Part No. TR-04

Sale Price: \$ 2,795.00

Material: Aluminum

Color: Black Texture

Max. Capacity: 1,000 lbs. / 454 kgs.

Weight: 100 lbs. / 45.5 kgs.

Dimensions: L55 3/16" x W24 1/2" x H52 3/4"
L140.2cm x W62.2cm x H134cm

(Case ready) L55 1/4" x W24 1/2" x H8 5/8"

(Case ready) L140.3cm x W62.2cm x H21.9cm

Features:

- Adjustable Top Shelf (L51" x W24 1/4" ID) (L129.5cm x W61.6cm ID)
- Stationary Bottom Shelf (L51" x W24 1/4" ID) (L129.5cm x W61.6cm ID)
- Full Size Push/Pull Handle
- Removable Wheels with Safety Lock
- Wheels: (2) 10" Rigid Caster & (2) 10" Swivel Caster With Brake
- Transformer system, fully collapsible
- 5/32" and 3/16" Allen Wrench is all you need to dismantle

Accessories:

- Dove Tail Mount w/ Front Box Holder (**TR-04 DT**) \$ 295.00
- Mitchell Mount w/ Front Box Holder (**TR-04 M**) \$ 315.00
- 75mm Euro Mount w/ Front Box Holder (**TR-04 EU-75**) \$ 355.00
- 100mm Euro Mount w/ Front Box Holder (**TR-04 EU-100**) \$ 365.00
- 150mm Euro Mount w/ Front Box Holder (**TR-04 EU-150**) \$ 385.00
- Front Box (**MAG-FB**) \$ 265.00
- Tripod Holder with Baby Pin (5/8") (**TR-04 TP**) \$ 255.00
- Cross Bar with Baby 5/8" Pin (**TR-04 S**) \$ 195.00
- Steadi-Cam Riser Unit with Bumper (**TR-04 SPR**) \$ 675.00
- Steadi-Cam Vest Holder (**TR-04 SV**) \$ 235.00
- Steadi-Cam Stand Holder (**MAG-SS ES**) \$ 75.00
- Push Handles (pair) (**TR-04 H**) \$ 140.00
- 46" Camera Utility Box (**MAG-UB46**) \$ 175.00
- Sand Dune Wheel Kit (**TR-04 W**) \$ 995.00
- ADP 5/8" Baby Pin (**PIN (ADP)**) \$ 95.00
- Umbrella Holder (detachable) (**MAG-UH**) \$ 150.00
- 51" Horizontal Cross Bar (**TR-04 SH**) \$ 175.00 (5/8" Snap-On Pin not included)
- 24" Cross Bar (**TR-04 SH CB**) \$ 140.00 (5/8" Snap-On Pin not included)
- Universal Snap-On 5/8" Baby Pin for Cross Bars (**TR-04 SHP**) \$ 55.00
- Universal Snap-On 1 1/8" Female Junior Receiver for Cross Bars (**TR-04 SHR**) \$ 97.00

Options:

- Foam Filled Tires (**WA-10 FOAM CTR**) \$ 240.00
- Middle Shelf (**TR-04 A3**) \$ 775.00

Replacement parts:

- 10" Pneumatic Tire (**WA-10 TIRE**) \$ 24.00
- 10" Pneumatic Tube (**WA-10 TUBE**) \$ 12.00
- 10" Pneumatic Rigid Caster Wheel (**W-10 RCX**) \$ 88.00
- 10" Pneumatic Swivel Caster Wheel with Brakes (**W-10 SCBRX**) \$ 98.00

Shipping Dimensions: L57" x W28" x H15" (143 lbs.) w/Pallet

L145cm x W71.1cm x H38.1cm (65 kgs.) w/Pallet



The Aluminum Camera Case Cart is a fully collapsible cart. It is held together by four round posts which attach to a bottom and top shelf by using telescopic locks operated with a 5/32 Allen wrench. All accessories are attached in the same manner. Top Shelf is adjustable and can be set at any height. The wheels are detached by sliding them out of a rail unit secured by a hex screw and safety button. Cart breaks down to a self-contained travel case.



Camera Case Cart (Cont.)

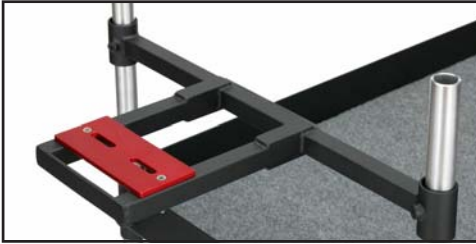

Dove Tail Mount (TR-04 DT)



Mitchell Mount (TR-04 M)

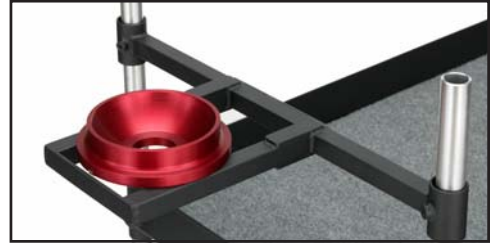

150mm Euroball Mount (TR-04 EU150)

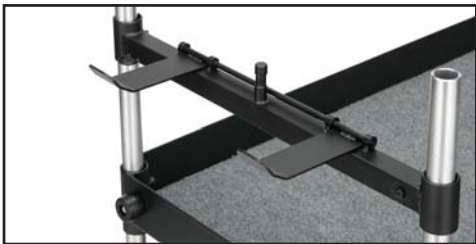

Tripod Holder with 5/8" Baby Pin (TR-04 TP)

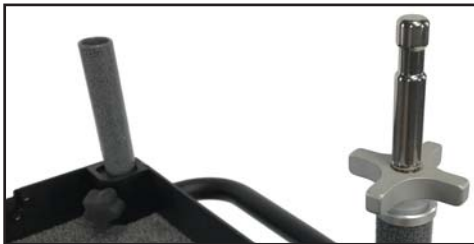

ADP 5/8" Baby Pin Mounted on Vertical Pole



Umbrella Holder (MAG-UH) mounted on Cross Bar

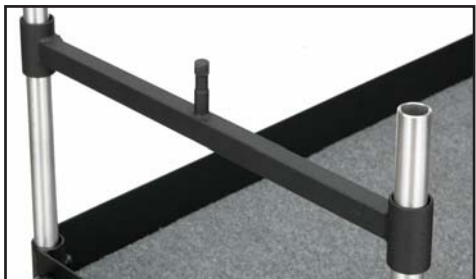

Cross Bar with 5/8" Baby Pin (TR-04 S)



Hi/Lo Hat Holder (TR-04 O)

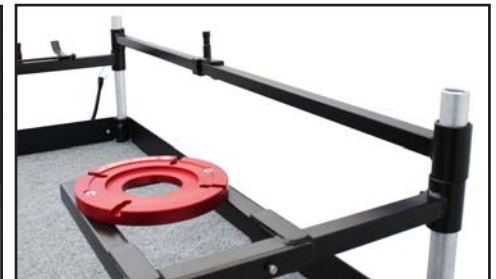

Horizontal Cross Bar with Universal Snap-On Pin



Universal Snap-On 5/8" Baby Pin (SHP)



New Style Support Corner with internal Locking Shoe



Steady-Cam Stand Holder (MAG-SS ES)

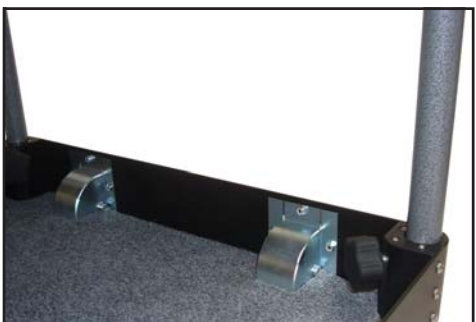



Camera Case Cart (Cont.)

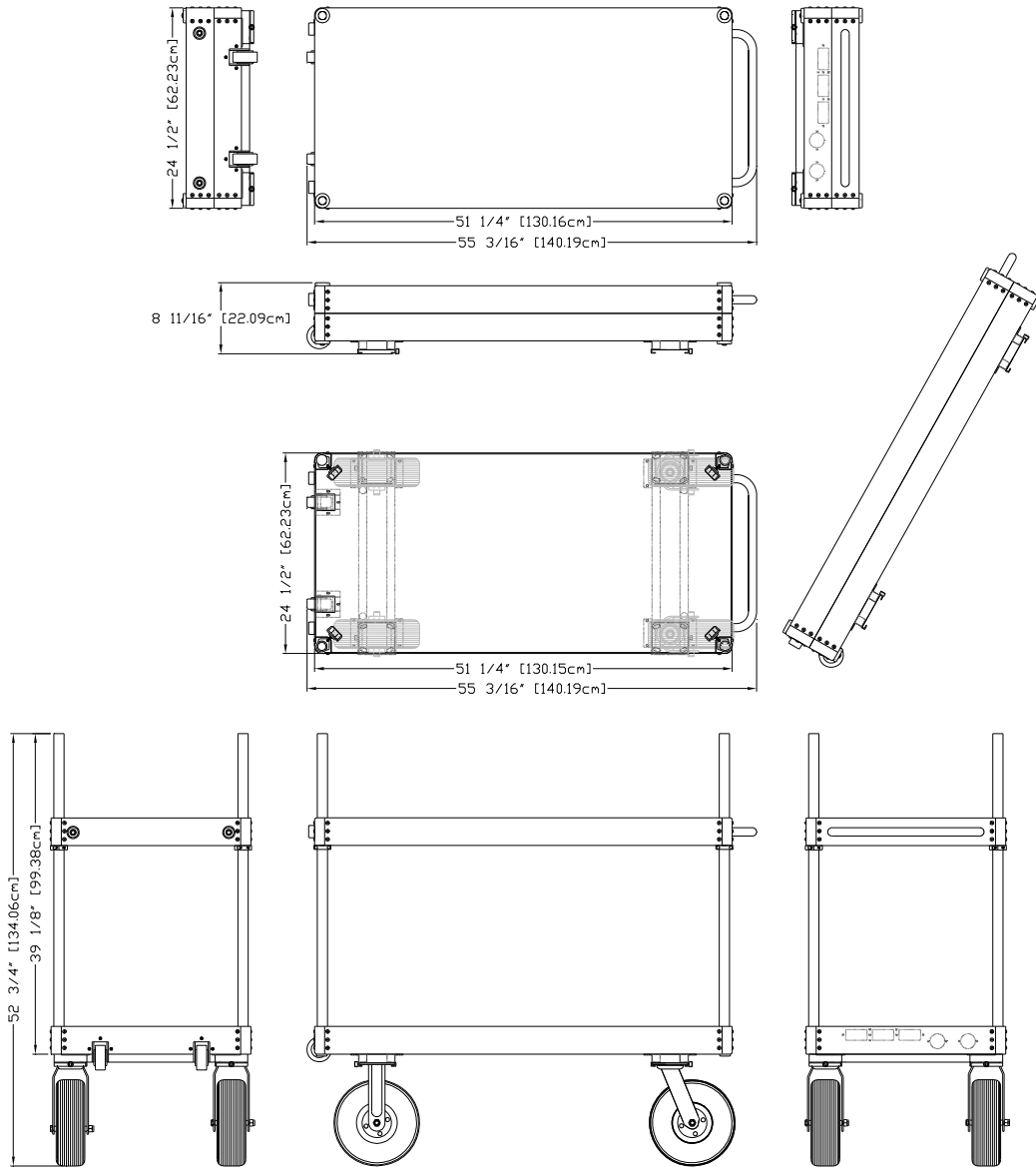



Junior Camera Case Cart (Aluminum)

Part No. TR-04 JR

Sale Price: \$ 2,695.00

Material: Aluminum

Color: Black Texture

Max. Capacity: 1,000 lbs. / 454 kgs.

Weight: 96 lbs. / 43.6 kgs.

Dimensions: L39 15/16" x W24 1/2" x H52 3/4"

L101.4cm x W62.2cm x H134cm

(Case ready) L39 15/16" x W24 1/2" x H8 11/16"

(Case ready) L101.4cm x W62.2cm x H22.1cm

Features:

- All aluminum construction
- Adjustable Top Shelf (L35 3/4" x W24 1/4" ID) (L90.1cm x W61.6cm ID)
- Stationary Bottom Shelf (L35 3/4" x W24 1/4" ID) (L90.1cm x W61.6cm ID)
- Full Size Push/Pull Handle
- A.C. Ready
- Wheels: (2) 10" Rigid Caster & (2) 10" Swivel Caster With Brake
- Transformer system, fully collapsible

Accessories:

- Dove Tail Mount w/ Front Box Holder (**TR-04 DT**) \$ 295.00
- Mitchell Mount w/ Front Box Holder (**TR-04/06 M**) \$ 315.00
- 75mm Euro Mount w/ Front Box Holder (**TR-04 EU-75**) \$ 355.00
- 100mm Euro Mount w/ Front Box Holder (**TR-04 EU-100**) \$ 365.00
- 150mm Euro Mount w/ Front Box Holder (**TR-04 EU-150**) \$ 385.00
- Front Box (**MAG-FB**) \$ 265.00
- Tripod Holder with Baby Pin (5/8") (**TR-04 TP**) \$ 255.00
- Cross Bar with Baby 5/8" Pin (**TR-04 S**) \$ 195.00
- Steadi-Cam Riser Unit with Bumper (**TR-04 SPR**) \$ 675.00
- Steadi-Cam Vest Holder (**TR-04 SV**) \$ 235.00
- Steadi-Cam Stand Holder (**MAG-SS ES**) \$ 75.00
- Push Handles (pair) (**TR-04 H**) \$ 140.00
- 31" Camera Case Cart Utility Box (**TR-04 JR UB31**) \$ 155.00
- Sand Dune Wheel Kit (**TR-04 W**) \$ 995.00
- ADP 5/8" Baby Pin (**PIN (ADP)**) \$ 95.00
- Umbrella Holder (detachable) (**MAG-UH**) \$ 150.00
- 36" Horizontal Cross Bar (**TR-04 JR SH**) \$ 165.00 (5/8" Snap-On Pin not included)
- 24" Cross Bar (**TR-04 SH CB**) \$ 140.00 (5/8" Snap-On Pin not included)
- Universal Snap-On 5/8" Baby Pin for Cross Bars (**TR-04 SHP**) \$ 55.00
- Universal Snap-On 1 1/8" Female Junior Receiver for Cross Bars (**TR-04 SHR**) \$ 97.00

Options:

- Foam Filled Tires (**WA-10 FOAM CTR**) \$ 240.00
- Middle Shelf (**TR-04 JR A3**) \$ 725.00

Replacement parts:

- 10" Pneumatic Tire (**WA-10 TIRE**) \$ 24.00
- 10" Pneumatic Tube (**WA-10 TUBE**) \$ 12.00
- 10" Pneumatic Rigid Caster Wheel (**W-10 RCX**) \$ 88.00
- 10" Pneumatic Swivel Caster Wheel with Brakes (**W-10 SCBRX**) \$ 98.00

Shipping Dimensions: L42" x W28" x H15" (135 lbs.) w/Pallet

L106.7cm x W71.1cm x H38.1cm (61.4 kgs.) w/Pallet



TR-04 JR shown with Dove Tail Mount and Tripod Holder

The Junior Camera Case Cart is a fully collapsible cart. It is held together by four round posts which attach to the Top and Bottom Shelf's special receiver, shelves are secured with a Hand Prong. All accessories are attached to the posts and secured with the use of a 5/32" Hex Wrench.

Top Shelf is adjustable and can be set at any height. Posts come with a built-in collar to help you set height at your preferred location.

The wheels are detached by sliding them out of a rail unit secured by a 5/32" hex screw and safety button.



TR-04 shown with Dove Tail Mount and Mag Front Box



Junior Camera Case Cart (Cont.)

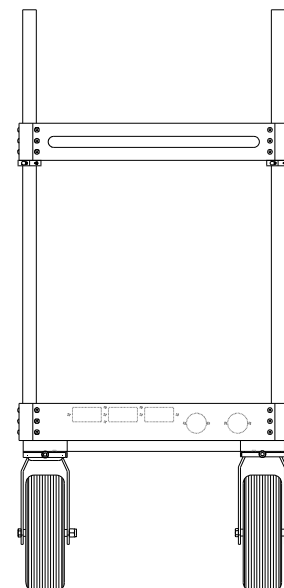
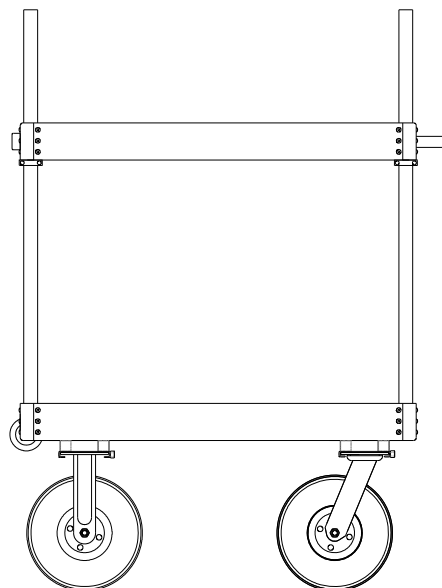
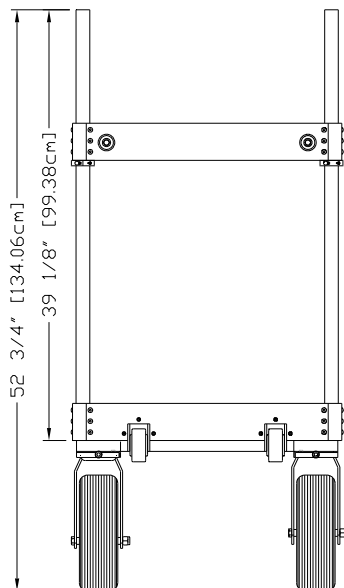
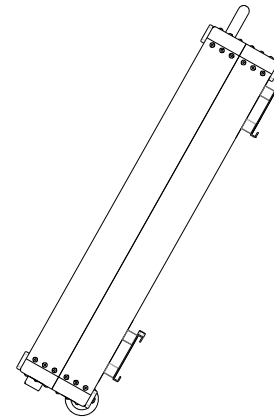
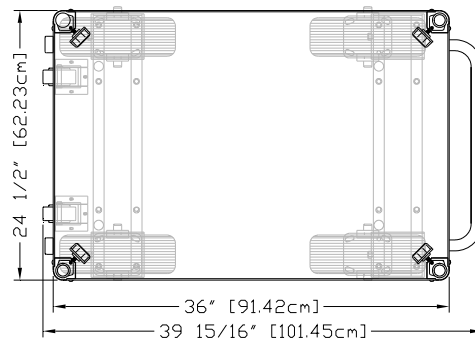
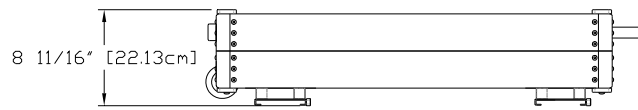
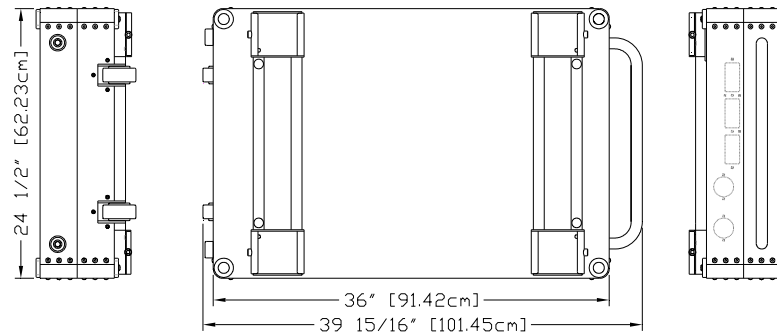



Stedi-Cam Case Cart

Part No. TR-05 EL

Sale Price: \$ 3,250.00

Material: Aluminum

Color: Black Texture

Max. Capacity: 1,000 lbs. / 454 kgs.

Weight: 115 lbs. / 52.3 kgs.

Dimensions: L55 3/16" x W28 1/4" x H52 7/16"
L140.2cm x W71.8cm x H133.2cm
L55 3/16" x W24 1/2" x H8 11/16" (Folded)
L140.2cm x W62.2cm x H22.7cm



Features:

- 4 Upright Round Tubes (L39" x 1 1/4" diam.) (L99cm x 3.2cm diam.)
- Adjustable Top Shelf (L36" x W24 1/2") (91.4cm x W62.2cm)
- Stationary Bottom Shelf (L51 1/4" x W24 1/2") (L130.2cm x W62.2cm)
- Removable Wheels with Safety Lock
- Wheels: 2-10" Rigid & 2-10" Swivel w/ brake
- Stedi-Cam Riser with Bumper (included)
- Telescopic Handles (Adjustable)
- Transformer system, fully collapsible
- 5/32" Allen wrench required to dismantle

Accessories:

- Stedi-Cam Vest Holder (TR-05 EL-SV) \$ 145.00
- Mag 35" Utility Box (MAG-UB35) \$ 165.00
- Sand/Dune Wheel Kit (TR-04 W) \$ 995.00

Options:

- Foam Filled Tires (WA-10 FOAM CTR) \$ 240.00

Replacement parts:

- 10" Pneumatic Tire (WA-10 TIRE) \$ 24.00
- 10" Pneumatic Tube (WA-10 TUBE) \$ 12.00
- 10" Pneumatic Rigid Caster Wheel (W-10 RCX) \$ 88.00
- 10" Pneumatic Swivel Caster Wheel with Brakes (W-10 SCBRX) \$ 98.00

Shipping Dimensions: L57" x W28" x H15" (158 lbs.) Includes Pallet
L144.8cm x W71.1cm x H38.1cm (71.8 kgs.)

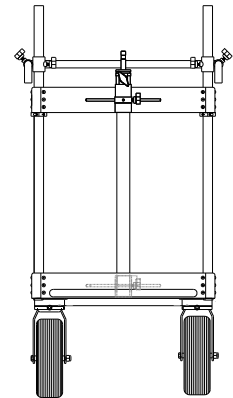
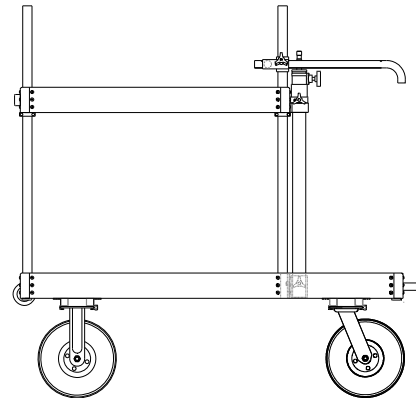
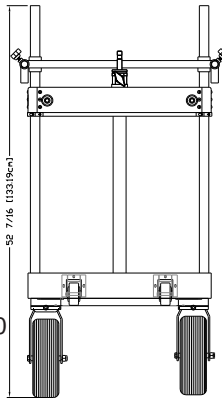
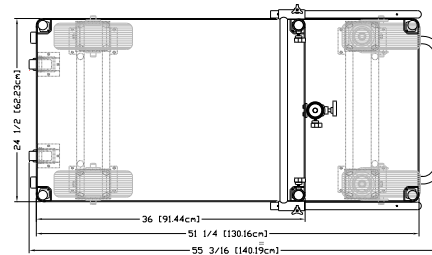

The Stedi-Cam Case Cart is a fully collapsible cart. The main feature of this cart is the protective front area where your Stedi-Cam unit and Camera is located. Handles are telescopic, they have a dual purpose, one to use to push the cart and the other one is to protect the gear on the sides.

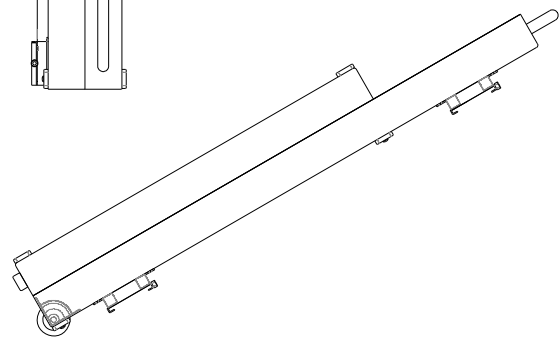
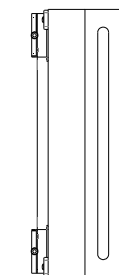
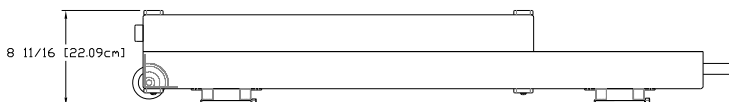
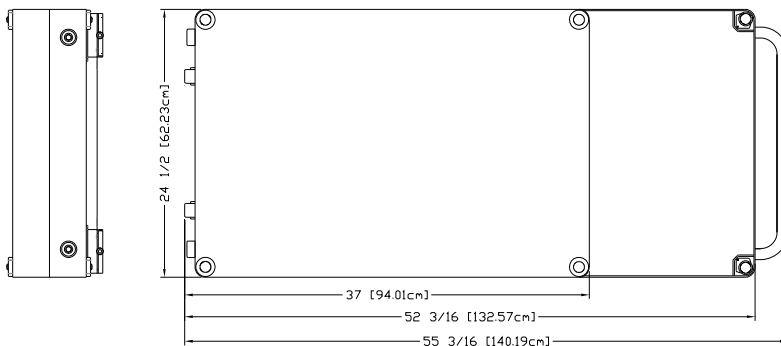



TR-01 8 Transformer Cart

Part No. TR-01 8

Sale Price: \$ 1,885.00

Material: Steel

Color: Black

Max. Capacity: 800 lbs. / 227 kgs.

Weight: 68 lbs. / 31 kgs.

Dimensions: D33" x W29 1/2" x H48"
L83.8cm x W75cm x H122cm

The Transformer Cart is a fully collapsible cart used for Video, Sound and Remote Head. It is held together by four vertical posts which attach to a Bottom, Middle and Top Shelf by using telescopic locks operated with a 5/32 Allen wrench. All accessories are attached in the same manner. Middle Shelf, Handles, Rack Mounts and all available accessories can be adjusted to your desired height.

Additional Rack Mounts may be installed on rear section of cart for additional accessories. Custom size vertical poles may be ordered to change height of cart.

Features:

- Top Shelf (D22" x W22" x H1" ID) (56cm x W56cm x H2.5cm ID)
- Middle Shelf (Adjustable) (D19 1/4" x W20" x H1" ID) (L49cm x W51cm x H2.5cm ID)
- Bottom Shelf (D19 1/4" x W20" x H1" ID) (L50cm x W51cm x H2.5cm ID)
- (2) Front Vertical Posts (L1" x W1" x H28") (L2.5cm x W2.5cm x H71.1cm")
- (2) Rear Vertical Posts (L1" x W1" x H39") (L2.5cm x W2.5cm x H99cm")
- (2) 5/8" Baby Pins accommodate Monitors, Monitor Trays and accessories
- (2) 19" Adjustable Rack Mounts (length 24 3/4") accommodate (14) Rack Mount spaces

Note: 1 Rack Mount space equals 1 3/4"

- (2) Handles with Cable Hooks
- (2) 5/8" Diameter Adjustable Axle Brackets outfitted with Sand/Dune Wheel Axle Receivers
- Wheels: (2) 8" Pneumatic Swivel Casters with Brake & (2) 16" Pneumatic Cable Crawlers
- Transformer system, fully collapsible



TR-01 8 Transformer Cart with optional Nagra Sound Tray (TR-01 N) and 4-Space Sliding Drawer with lock. (MAG-L4)

Accessories:

- Nagra Sound Tray (TR-01 N) \$ 195.00
- Loading Wheel Kit (TR-01 LX) \$ 150.00
- 3" Cable Hook (Left / Right) (TR-01 CH3-L / TR-01 CH3-R) \$ 36.00
- 6" Cable Hook (Left / Right) (TR-01 CH6-L / TR-01 CH6-R) \$ 44.00
- VPB Trans 5/8" Baby Pin (TR-01 S) \$ 35.00
- VPB 5/8" Baby Pin (Left) (TR-01 S-L) \$ 66.00
- VPB 5/8" Baby Pin (Right) (TR-01 S-R) \$ 66.00
- VPB Snap-On 5/8" Baby Pin (TR-01 S-SO) \$ 81.00
(See CAD drawing on page 115) (Same as TR-01 S-L and TR-01 S-R, but can be installed without taking cart apart)
- VPB 5/8" Baby Pin (Left) Set at 45 degrees (TR-01 S-L 45) \$ 70.00
- VPB 5/8" Baby Pin (Right) Set at 45 degrees (TR-01 S-R 45) \$ 70.00
- Mic Boom Grip & Base (MAG-R2 LK-X) \$ 130.00
- Mic Boom Grip & Base (MAG-R4 LK-X) \$ 140.00
- Drawer (2-space) latch & lock (MAG-L2 PE-15) \$ 175.00
- Drawer (3-space) latch & lock (MAG-L3 PE-15) \$ 190.00
- Drawer (4-space) latch & lock (MAG-L4 PE-15) \$ 215.00
- Sliding Shelf with Lock (1-space) (TR-01 SS) \$ 275.00
- 24" Rack Mount (Set) (TR-01 R24X) \$ 175.00
- Umbrella (MAG-U) \$ 235.00 (Hardware only) Must select canvas to complete part, see below.
- Mag Umbrella Canvas (Black) (MAG-U A-BK) \$ 95.00
- Mag Umbrella Canvas (White) (MAG-U A-W) \$ 110.00
- Mag Umbrella Canvas (Red) (MAG-U A-R) \$ 110.00
- Umbrella Holder (MAG-UH) \$ 150.00
- VPB Cross Bar with 5/8" Baby Pin (TR-01 S-CB) \$ 145.00
- Rain Tent Umbrella w/ Skirts (MAG-U RT) \$ 1,375.00
- HD DIT Tent (MAG-U HD) \$ 1,275.00



TR-01 8 Transformer Cart in loading position with optional Loading Wheel Kit (TR-01 LX), Nagra Sound Tray (TR-01 N) and 4-Space Sliding Drawer with lock. (MAG-L4)



TR-01 8 Transformer Cart (Cont.)

Accessories (Cont.):

- VPB Vertical Baby Riser (Adjustable) **(TR-01 VPR)** \$ 310.00 (Includes one of each: MAG-LCD TH-LD BK-X, MAG-LCD MR-04, MAG-01 VPR-B ST, TR-01 Z)
- Mag LCD Tilter Head with 75/100mm VESA Plate (0-35 lbs.) **(MAG-LCD TH-LD BK-X)** \$ 98.00
- Mag LCD Tilter Head with 75/100mm VESA Plate (20-35 lbs.) **(MAG-LCD TH-MD BK-X)** \$ 125.00
- Mag LCD 4" Tilt Head Pin Adapter **(MAG-LCD MR-04)** \$ 50.00
- Mag Baby Pin Riser **(MAG-01 VPR-B ST)** \$ 122.00
- VPB Adapter to Mag Baby Pin Riser **(TR-01 Z)** \$ 39.00

Options:

- 20" Knobby BMX Wheel Set (5/8 Bore) **(W-20 58X)** \$ 240.00
- VPB 20" Wheel Axle Set **(TR-01 D20-X)** \$ 160.00

Replacement parts:

- 8" Pneumatic Swivel Caster Wheel with Brake **(W-08 SCBRX)** \$ 85.00
- 16" Pneumatic Wheel with 5/8" Bearings **(W-16 CC58X)** \$ 120.00
- 16" Pneumatic Tire **(WA-16 CC TIRE)** \$ 28.00
- 16" Pneumatic Tube **(WA-16 CC TUBE)** \$ 16.00
- 5/8" Sealed Bearing **(WA-58 BR)** \$ 2.75 (2) needed per wheel

Shipping Dimensions: L26" x W26" x H26" (80 lbs.) & L5" x W5" x H45" (11 lbs.)
 L66cm x W66cm x H66cm (36.4 kgs.) &
 L12.7cm x W12.7cm x H114.3cm (5 kgs.)

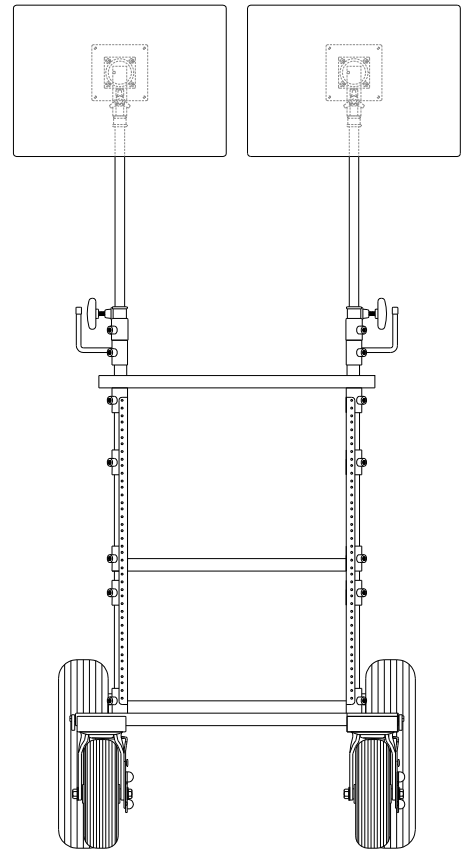

TR-01 8 shown with (2) TR-01 VPR units, includes the following accessories:
(MAG-LCD TH-LD BK) Mag LCD Tilter Head with 75/100mm VESA Adapter Plate (3-24 lbs.) (2)
(MAG-LCD MR-04) Mag LCD 4" Tilt /Head Pin to 5/8" Baby Pin Adapter. (2)
(MAG-01 VPR-B ST) Mag Baby Pin Extension Riser (Steel) (2)
(TR-01 Z) VPB Adapter to Mag Baby Pin Riser (2)

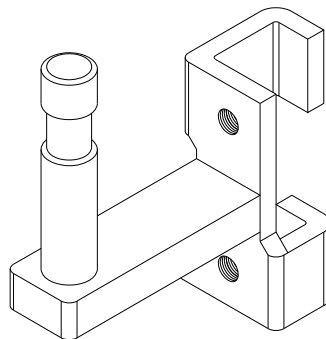
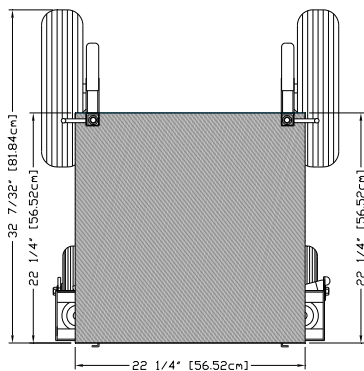

TR-01 S-SO VPB Snap-On 5/8" Baby Pin \$ 81.00

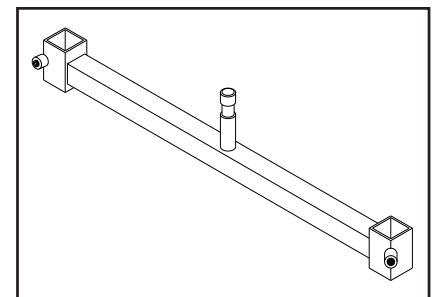

TR-01 S-CB Cross Bar with 5/8" Baby Pin \$ 145.00

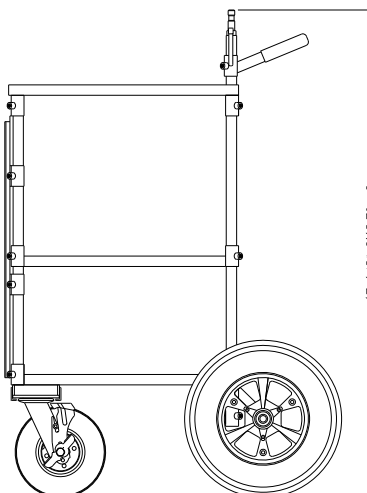
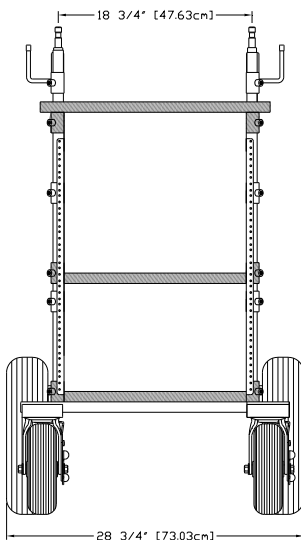

TR-01-8 Cart shown with optional Sand/Dune Wheel Kit (TR-01 8-W)



TR-01 EFX-8 Transformer Cart

Part No. TR-01 EFX-8

Sale Price: \$ 2,085.00

Material: Steel

Color: Black

Max. Capacity: 500 lbs. / 227 kgs.

Weight: 65 lbs. / 29.6 kgs.

Dimensions: D33" x W29 1/2" x H44 1/2"

L83.8cm x W75cm x H113cm

Same as the TR-01 8 Transformer Cart but with the ability to install an optional Sliding K/B & Mouse Tray.

Cart is held together by four vertical posts which attach to a Bottom, Middle and Top Shelf by using telescopic locks operated with a 5/32 Allen wrench. All accessories are attached in the same manner. Middle Shelf, Handles, Rack Mounts and all available accessories can be adjusted to your desired height.

Additional Rack Mounts may be installed on rear section of cart for additional accessories. Custom size vertical poles may be ordered to change height of cart.

Features:

- Top Shelf (D22" x W22" x H1") (56cm x W56cm x H2.5cm)
- Middle Shelf (Adjustable) (D19 1/2" x W22" x H1") (L50cm x W56cm x H2.5cm)
- Bottom Shelf (D19 1/2" x W20" x H1") (L50cm x W51cm x H2.5cm)
- (2) Front Vertical Posts (L1 x W1" x H28") (L2.5cm x W2.5cm x H71.1cm")
- (2) Rear Vertical Posts (L1 x W1" x H39") (L2.5cm x W2.5cm x H99cm")
- (2) 5/8" Baby Pins accommodate Monitors, Monitor Trays and accessories
- (2) 19" Adjustable Rack Mounts (length 24 3/4") accommodate (14) Rack Mount spaces (1 Rack Mount space equals 1 3/4")
- (2) Handles with Cable Hooks
- (2) 5/8" Diameter Adjustable Axles
- Wheels: (2) 8" Pneumatic Swivel Casters with Brake & (2) 16" Pneumatic Cable Crawlers
- Transformer system, fully collapsible

Accessories:

- Nagra Sound Tray (TR-01 N) \$ 195.00
- Loading Wheel Kit (TR-01 LX) \$ 150.00
- 3" Cable Hook (Left / Right) (TR-01 CH3-L / TR-01 CH3-R) \$ 36.00
- 6" Cable Hook (Left / Right) (TR-01 CH6-L / TR-01 CH6-R) \$ 44.00
- VPB Trans 5/8" Baby Pin (TR-01 S) \$ 35.00
- VPB 5/8" Baby Pin (Left) (TR-01 S-L) \$ 66.00
- VPB 5/8" Baby Pin (Right) (TR-01 S-R) \$ 66.00
- VPB Snap-On 5/8" Baby Pin (TR-01 S-SO) \$ 81.00
(See CAD drawing on page 87) (Same as TR-01 S-L and TR-01 S-R, but can be installed without taking cart apart)
- VPB 5/8" Baby Pin (Left) Set at 45 degrees (TR-01 S-L 45) \$ 70.00
- VPB 5/8" Baby Pin (Right) Set at 45 degrees (TR-01 S-R 45) \$ 70.00
- Mic Boom Grip & Base (MAG-R2 LK-X) \$ 130.00
- Mic Boom Grip & Base (MAG-R4 LK-X) \$ 140.00
- Drawer (2-space) latch & lock (MAG-L2 PE-15) \$ 175.00
- Drawer (3-space) latch & lock (MAG-L3 PE-15) \$ 190.00
- Drawer (4-space) latch & lock (MAG-L4 PE-15) \$ 215.00
- Sliding Shelf with Lock (1-space) (TR-01 SS) \$ 275.00
- K/B Mouse Slide Tray (TR-01 MDKB) \$ 310.00
- 24" Rack Mount (Set) (TR-01 R24X) \$ 175.00
- Umbrella (MAG-U) \$ 235.00 (Hardware only) Must select canvas to complete part, see below.
- Mag Umbrella Canvas (Black) (MAG-U A-BK) \$ 95.00
- Mag Umbrella Canvas (White) (MAG-U A-W) \$ 110.00
- Mag Umbrella Canvas (Red) (MAG-U A-R) \$ 110.00
- Umbrella Holder (MAG-UH) \$ 150.00
- VPB Cross Bar with 5/8" Baby Pin (TR-01 S-CB) \$ 145.00
- Rain Tent Umbrella w/ Skirts (MAG-U RT) \$ 1,375.00
- HD DIT Tent (MAG-U HD) \$ 1,275.00



TR-01 EFX shown with optional Sliding K/B & Mouse Tray, Nagra Tray, Sliding Shelf, 3-Space Sliding Drawer w/ lock & 9-Outlet Power Strip





TR-01 EFX-8 Transformer Cart (Cont.)

Accessories (Cont.):

- VPB Vertical Baby Riser (Adjustable) (**TR-01 VPR**) \$ 310.00 (Includes one of each: MAG-LCD TH-LD BK-X, MAG-LCD MR-04, MAG-01 VPR-B ST, TR-01 Z)
- Mag LCD Tilter Head with 75/100mm VESA Plate (0-35 lbs.) (**MAG-LCD TH-LD BK-X**) \$ 98.00
- Mag LCD Tilter Head with 75/100mm VESA Plate (20-35 lbs.) (**MAG-LCD TH-MD BK-X**) \$ 125.00
- Mag LCD 4" Tilt Head Pin Adapter (**MAG-LCD MR-04**) \$ 50.00
- Mag Baby Pin Riser (**MAG-01 VPR-B ST**) \$ 122.00
- VPB Adapter to Mag Baby Pin Riser (**TR-01 Z**) \$ 39.00

Options:

- K/B Mouse Slide Tray (**TR-01 MDKB**) \$ 310.00
- 20" Knobby BMX Wheel Set (5/8 Bore) (**W-20 58X**) \$ 240.00
- VPB 20" Wheel Axle Set (**TR-01 D20-X**) \$ 160.00

Replacement parts:

- 8" Pneumatic Swivel Caster Wheel with Brake (**W-08 SCBRX**) \$ 85.00
- 16" Pneumatic Wheel with 5/8" Bearings (**W-16 CC58X**) \$ 120.00
- 16" Pneumatic Tire (**WA-16 CC TIRE**) \$ 28.00
- 16" Pneumatic Tube (**WA-16 CC TUBE**) \$ 16.00
- 5/8" Sealed Bearing (**WA-58 BR**) \$ 2.75 (2) needed per wheel)

- Shipping Dimensions:** (4) Boxes
- L26" x W26" x H14" (51 lbs.)
 - L66cm x W66cm x H35.6cm (23.2 kgs.)
 - L31" x W25" x H6" (13 lbs.)
 - L78.7cm x W63.5cm x H15.2cm (5.9 kgs.)
 - L31" x W25" x H6" (17 lbs.)
 - L78.7cm x W63.5cm x H15.2cm (7.7 kgs.)
 - L5" x W5" x H45" (11 lbs.)
 - L12.7cm x W12.7cm x H114.3cm (5 kgs.)

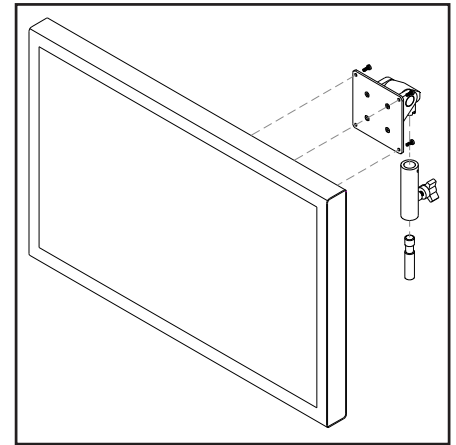

MAG-LCD TH-LD BK with MAG-LCD MR-04 docked on 5/8" Baby Pin

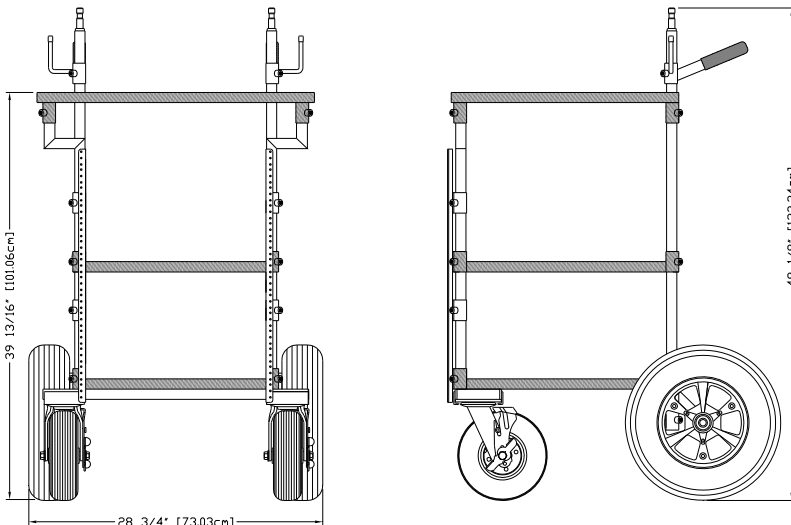
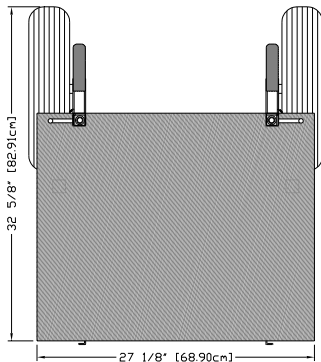

TR-01 EFX-8 shown with optional Sliding K/B & Mouse Tray (TR-01 MDKB), Mag Lap Top Tray (MAG-LTP), Mag Swing Arm (MAG-LTA), VPB 5/8" Baby Pin (L) set at 45 degrees (TR-01 S-L 45), Mag Offset Arms (MAG-V OS), Mag-LCD 8" Tilt Head Pin Adapters (MAG-LCD MR-08), Mag LCD Tilter Head with 75/100mm VESA Plates (MAG-LCD TH-LD BK)



Mag LCD 75/100mm Tilt Head (MAG-LCD TH-LD BK) & Mag LCD 8" Tilt Head Pin Adapter (MAG-LCD MR-08) attached to TR-01 VPB Cart's 5/8" Baby Pin



Terms & Conditions

WARRANTY

All equipment and accessories manufactured by BACKSTAGE EQUIPMENT, INC. are warranted for life against defects. BACKSTAGE EQUIPMENT reserves the right to determine whether the equipment manufactured by BACKSTAGE EQUIPMENT is subject to the warranty or guarantee set forth by the manufacturer, and then only to the extent BACKSTAGE EQUIPMENT is able to enforce the warranty or guarantee.

TERMS

30-Days Net upon BACKSTAGE EQUIPMENT management credit approval. A monthly late charge of 1.5% or maximum allowable rate shall be added to all overdue amounts. Buyers account will be placed on hold if late charge is unpaid. If it becomes necessary to institute legal proceedings to collect this or any other account which you may have with BACKSTAGE EQUIPMENT, the prevailing party shall be entitled to the costs of collection, including reasonable attorney's fees. Title to all goods covered hereon shall not transfer to Buyer until full payment has been accepted by BACKSTAGE EQUIPMENT.

TRANSPORTATION

All items are FOB North Hollywood, CA, USA, with Buyer assuming responsibility for all shipping charges. BACKSTAGE EQUIPMENT'S responsibility ceases upon delivery of the shipment to the carrier. Any loss or damage occurring in transit is the responsibility of the carrier and Buyers are advised to immediately notify the carrier in writing of any such loss or damage.

PACKING

All packing and crating is subject to a 5% charge of the net price.

PRICES & SPECIFICATIONS

All prices and specifications are subject to change without notice. All applicable Federal excise, State and/or local taxes will be added to the purchase price.

RETURNS & DELIVERIES

Equipment returns are not accepted without written authorization from BACKSTAGE EQUIPMENT. Any returns are subject to a 20% restocking charge. All deliveries are based on normal conditions. BACKSTAGE EQUIPMENT assumes no responsibility for delays caused by fire, riots, acts of God, government orders, strikes, lockouts, available supply of raw materials, transportation facilities, or other causes affecting production or delivery beyond our reasonable control.

NOTES

All prices are in U.S. Dollars.





Backstage Equipment, Inc.

2nd edition

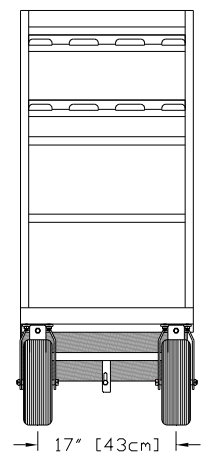
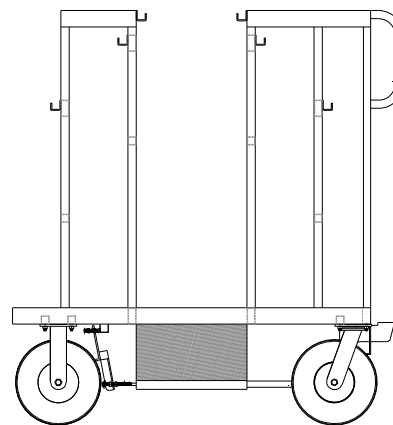
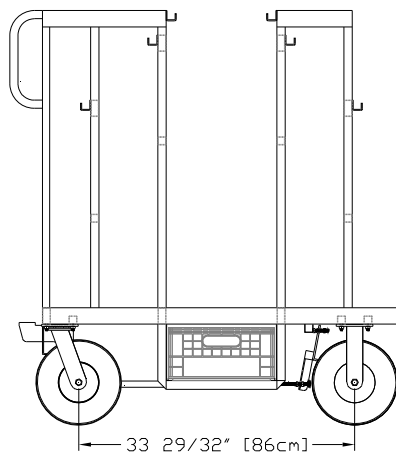
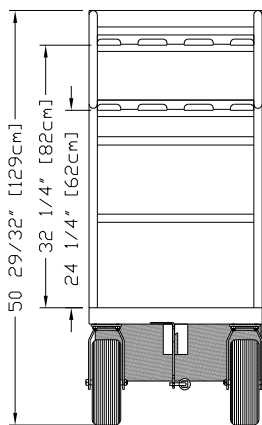
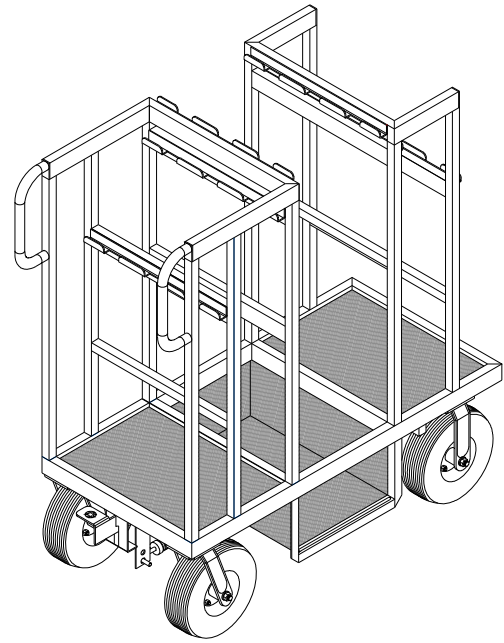
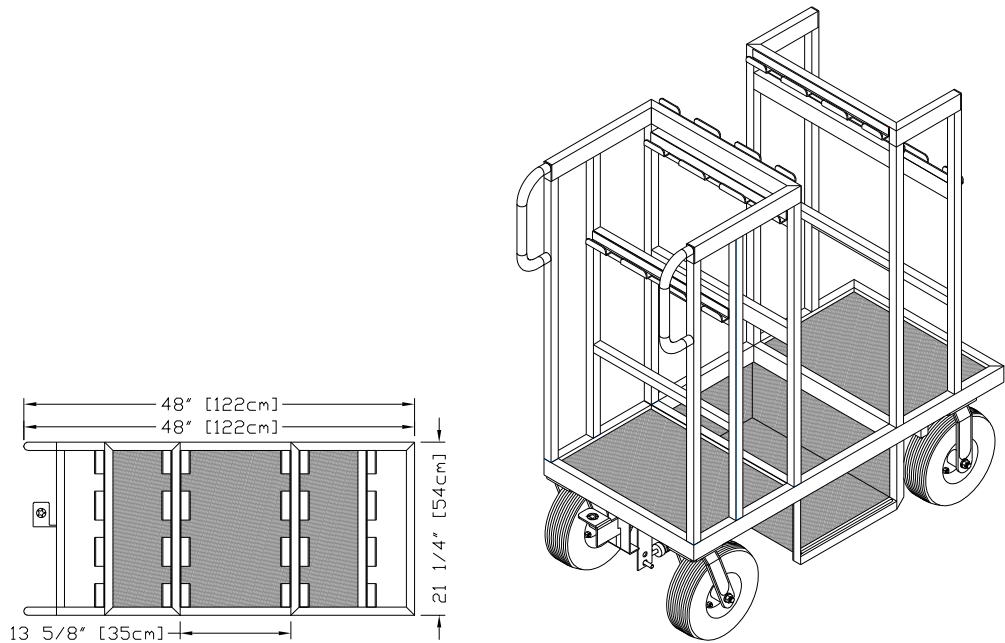

Backstage Equipment, Inc. • 8052 Lankershim Bl. • North Hollywood, CA 91605 • USA
(800) 692-2787 • (818) 504-6026 • Fax (818) 504-6180 • E-mail info@backstageweb.com • www.backstageweb.com